

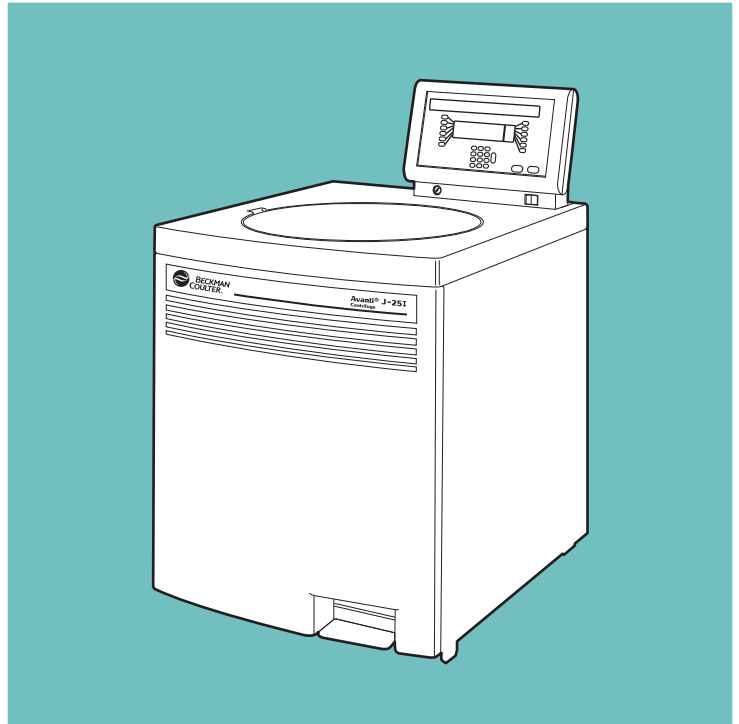

# Avanti® J-25 I High-Performance Centrifuge

Instruction Manual



Symbol Symbol Symbole Símbolo	Simbolo 記号 符号 Title / Titel / Titre / Titolo / Titolo / 名称 / 名称
	Dangerous voltage Gefährliche elektrische Spannung Courant haute tension Voltaje peligroso Pericolo: alta tensione <b>危険電圧</b> <b>危险电压</b>
	Attention, consult accompanying documents Achtung! Begleitpapiere beachten! Attention, consulter les documents joints Atención, consulte los documentos adjuntos Attenzione: consultare le informazioni allegate <b>注意、添付資料を参照のこと</b> <b>注意，请参阅附带的文件</b>
	On (power) Ein (Netzverbindung) Marche (mise sous tension) Encendido Acceso (sotto tensione) <b>入（電源）</b> <b>开（电源）</b>
	Off (power) Aus (Netzverbindung) Arrêt (mise hors tension) Apagado Spento (fuori tensione) <b>切（電源）</b> <b>关（电源）</b>
	Protective earth (ground) Schutzleiteranschluß Liaison à la terre Puesta a tierra de protección Collegamento di protezione a terra <b>保護アース（接地）</b> <b>保护接地</b>
	Earth (ground) Erde Terre Tierra Scarica a terra <b>アース（接地）</b> <b>接地</b>



## **SAFETY NOTICE**

This safety notice summarizes information basic to the safe operation of the equipment described in this manual. The international symbol displayed above is a reminder that all safety instructions should be read and understood before installation, operation, maintenance, or repair of this instrument. When you see the symbol on other pages, pay special attention to the safety information presented. Observance of safety precautions will also help to avoid actions that could damage or adversely affect the performance of the centrifuge.

### **Safety During Installation and/or Maintenance**

This centrifuge is designed to be installed by a Beckman Coulter field service representative. Installation by anyone other than authorized Beckman Coulter personnel invalidates any warranty covering the instrument.

Any servicing of this equipment that requires removal of any covers can expose parts which involve the risk of electric shock or personal injury. Make sure that the power switch is turned off and the instrument is disconnected from the main power source, and refer such servicing to qualified personnel.

Be sure to use the anchoring system to secure the centrifuge in place. The anchoring system is designed to reduce the possibility of injury or damage which could result from instrument movement in the event of a major rotor mishap.

### **Electrical Safety**

To reduce the risk of electrical shock, this equipment uses a three or five-wire electrical cord and plug to connect this equipment to earth-ground. To preserve this safety feature:

- Make sure that the matching wall outlet receptacle is properly wired and earth-grounded. Check that the line voltage agrees with the voltage listed on the name-rating plate affixed to the centrifuge.
- Never use a three-to-two wire plug adapter.
- Never use a two-wire extension cord or a two-wire non-grounding type of multiple-outlet receptacle strip.

Do not place containers holding liquid on or near the chamber door. If they spill, liquid may get into the centrifuge and damage electrical or mechanical components.

### **Safety Against Risk of Fire**

This centrifuge is not designed for use with materials capable of developing flammable or explosive vapors. Do not centrifuge such materials (for example, chloroform or ethyl alcohol) in this instrument nor handle or store them near the centrifuge.

## **Mechanical Safety**

For safe operation of the equipment, observe the following:

- Use only the Beckman Coulter rotors and accessories designed for use in this centrifuge.
- Do not exceed the maximum rated speed of the rotor in use.
- NEVER attempt to slow or stop a rotor by hand.
- Do not lift or move the centrifuge while a rotor is spinning.
- NEVER attempt to override the door interlock system while the rotor is spinning.
- Do not lean on the centrifuge or place items on it while it is operating.

## **Chemical and Biological Safety**

Normal operation may involve the use of solutions and test samples that are pathogenic, toxic, or radioactive. Such materials should not be used in this centrifuge, however, unless *all necessary safety precautions are taken*.

- Observe all cautionary information printed on the original solution containers prior to their use.
- Handle body fluids with care because they can transmit disease. No known test offers complete assurance that these fluids are free of micro-organisms. Some of the most virulent—Hepatitis (B and C) viruses and HIV (I–V), atypical mycobacteria, and certain systemic fungi—further emphasize the need for aerosol protection. Handle other infectious samples according to good laboratory procedures and methods to prevent spread of disease. Because spills may generate aerosols, observe proper safety precautions for aerosol containment. Do not run toxic, pathogenic, or radioactive materials in this centrifuge without taking appropriate safety precautions. Biosafe containment should be used when Risk Group II materials (as identified in the World Health Organization *Laboratory Biosafety Manual*) are handled; materials of a higher group require more than one level of protection.
- Dispose of all waste solutions according to appropriate environmental health and safety guidelines.

**It is your responsibility to decontaminate the instrument and accessories before requesting service by Beckman Coulter Field Service.**

# Avanti® J-25 I

## High-Performance Centrifuge

### Instruction Manual

© 2007 Beckman Coulter, Inc.  
Printed in the U.S.A.  
JUC-0107-PDF



CE



	Page
<b>INTRODUCTION</b>	
<i>Certification</i> . . . . .	vii
<i>Scope of this Manual</i> . . . . .	vii
<i>Conventions</i> . . . . .	viii
<i>Radio Interference</i> . . . . .	ix
<i>Recycling Label</i> . . . . .	x
<b>SECTION 1: SPECIFICATIONS AND PREINSTALLATION REQUIREMENTS</b>	
Specifications . . . . .	1-1
Control Features. . . . .	1-1
Operational Features . . . . .	1-2
Physical Data. . . . .	1-2
Available Rotors. . . . .	1-3
Preinstallation Requirements . . . . .	1-7
Electrical Requirements. . . . .	1-7
Space and Location Requirements. . . . .	1-10
Securing the Centrifuge to the Floor . . . . .	1-12
Using J2 Series Rotors in the Avanti J. . . . .	1-12
Checking for Rotor Drive Pins . . . . .	1-13
Using the JA-18 Rotor. . . . .	1-14
Using the JCF-Z Continuous Flow/Zonal Rotor . . . . .	1-14
<b>SECTION 2: DESCRIPTION</b>	
Centrifuge Function and Safety Features . . . . .	2-1
Centrifuge Function. . . . .	2-1
Safety Features. . . . .	2-2
Housing and Door . . . . .	2-3
Rotor Chamber. . . . .	2-3
Drive . . . . .	2-4
Friction Reduction System (FRS) . . . . .	2-4
Temperature Sensing and Control. . . . .	2-4
Overtemp System. . . . .	2-5
Name Rating Plate . . . . .	2-5
Controls and Indicators . . . . .	2-5
Power Switch and Key Switches. . . . .	2-5
Control Panel. . . . .	2-6
Keypad. . . . .	2-10
System Keys . . . . .	2-11

**SECTION 3: OPERATION**

Summary of Run Procedures . . . . .	3-2
Manual Run . . . . .	3-2
Programmed Run . . . . .	3-3
Preparation . . . . .	3-3
Installing the Rotor . . . . .	3-3
Manual Operation . . . . .	3-4
Selecting a Rotor . . . . .	3-5
Entering Run Speed . . . . .	3-5
Entering Run Time . . . . .	3-7
Entering Run Temperature . . . . .	3-10
Entering Acceleration and Deceleration Rates . . . . .	3-11
Starting a Run . . . . .	3-13
Changing Parameters During a Run . . . . .	3-13
Ending a Run . . . . .	3-13
Programmed Operation . . . . .	3-14
Creating a New Program . . . . .	3-14
Modifying a Program . . . . .	3-16
Running a Program . . . . .	3-17
Setting Up a Zonal Run . . . . .	3-17
Setting Up an Elutriation Run . . . . .	3-19

**SECTION 4: TROUBLESHOOTING**

User Messages . . . . .	4-1
Accessing the Rotor in Case of Power Failure . . . . .	4-5
JCF-Z Rotor Identification . . . . .	4-10

**SECTION 5: CARE AND MAINTENANCE**

Maintenance . . . . .	5-2
Cleaning . . . . .	5-2
Decontamination . . . . .	5-3
Sterilization and Disinfection . . . . .	5-3
Replacing the Air Filter . . . . .	5-4
Circuit Breaker and Fuses . . . . .	5-4
Storage and Transport . . . . .	5-5
Storage . . . . .	5-5
Returning a Centrifuge . . . . .	5-5
Supply List . . . . .	5-6
Replacement Parts and Supplies . . . . .	5-6

**APPENDIX: TEMPERATURE CALIBRATION PROCEDURE**

**WARRANTY**



# Illustrations

---

	Page
Figure 1-1. Single-Phase Electrical Requirements . . . . .	1-9
Figure 1-2. Three-Phase “Y” Electrical Requirements . . . . .	1-9
Figure 1-3. Correct and Incorrect Three-Phase Power Configurations . . . . .	1-10
Figure 1-4. Rear View and Dimensions . . . . .	1-11
Figure 1-5. Checking the Rotor for Drive Pins . . . . .	1-13
Figure 2-1. Power and Key Switches . . . . .	2-5
Figure 2-2. The Control Panel . . . . .	2-7
Figure 2-3. The Actual Value Display . . . . .	2-7
Figure 2-4. The Setup Screen . . . . .	2-8
Figure 3-1. Elutriation Controls . . . . .	3-19
Figure 4-1. Emergency Door Release Latch Access . . . . .	4-6
Figure 4-2. Manual Door Release . . . . .	4-7
Figure 4-3. Venting the Chamber Vacuum . . . . .	4-9
Figure 4-4. Front Panel Retaining Strip . . . . .	4-10

# Tables

---

	Page
Table 1-1. Nominal Instrument Voltage Ratings . . . . .	1-8
Table 1-2. Required Wire Connections . . . . .	1-9
Table 3-1. Acceleration and Deceleration Settings . . . . .	3-11
Table 4-1. Diagnostic Message Chart . . . . .	4-2

## CERTIFICATION

To ensure full system quality, Beckman Coulter Avanti® J-25 I centrifuges are manufactured in a registered ISO 9001 facility. They have been designed and tested to be compliant (when used with Beckman Coulter rotors) with the laboratory equipment requirements of applicable regulatory agencies. Declarations of conformity and certificates of compliance are available at [www.beckmancoulter.com](http://www.beckmancoulter.com).

## SCOPE OF THIS MANUAL

This manual is designed to familiarize you with the Avanti® J-25 I centrifuge, its functions, specifications, operation, and routine operator care and maintenance. We recommend that you read this entire manual, especially the SAFETY NOTICE and all safety-related information, before operating the instrument or performing instrument maintenance.

- Section 1 contains system specifications and instructions for preparing your site for installation of the centrifuge.
- Section 2 contains an overall description of the centrifuge, including a description of system controls and indicators.
- Section 3 summarizes procedures for operating the centrifuge.
- Section 4 lists possible error messages and/or malfunctions, together with probable causes and required corrective actions.
- Section 5 contains procedures for routine maintenance, as well as a brief list of supplies and replacement parts.
- The Appendix contains a procedure to use when temperature control within  $\pm 1^{\circ}\text{C}$  is required.

 **NOTE**

---

If the centrifuge is used in a manner other than specified in this manual, the safety and performance of this equipment could be impaired. Further, the use of any equipment other than that recommended by Beckman Coulter has not been evaluated for safety. Use of any equipment not specifically recommended in this manual is the sole responsibility of the user.

---

## CONVENTIONS

Certain symbols are used in this manual to call out safety related and other important information. These international symbols may also be displayed on the centrifuge and are reproduced and described below and on the inside of the front cover.

## NOTES, CAUTIONS, AND WARNINGS

---

 **NOTE**

---

Used to call attention to information that should be followed during installation, use, and/or servicing of the equipment.

---

 **CAUTION**

---

*Used to indicate a potentially hazardous situation which, if not avoided, may result in minor or moderate injury and/or mechanical damage. It is also used to alert against unsafe practices.*

---

**WARNING**

Used whenever an action or condition may potentially cause serious personal injury or loss of life. Mechanical damage may also result.

**WARNING**

Indicates high voltage or risk of electric shock. Refer servicing of all areas displaying this symbol to service personnel.

## TYPOGRAPHIC CONVENTIONS

---

Certain typographic conventions are used throughout this manual to distinguish names of user interface components, such as keys and displays.

- *Key names* (for example, [START] and [STOP]) appear in capital letters within brackets.
- Actual value display names and setup screen field names (for example, TEMP°C and Rotor:) appear in bold type.

## RADIO INTERFERENCE

This instrument has been tested and found to comply with the limits for a Class A digital device, pursuant to Part 15 of FCC Rules. These limits are designed to provide reasonable protection against harmful interference when the equipment is operated in a commercial environment. This equipment generates, uses, and can radiate radio frequency energy and, if not installed and used in accordance with this instruction manual, may cause interference to radio communications. Operation of this equipment in a residential area may cause interference, in which case the user will be required to correct the interference at his own expense.

## CANADIAN REGULATIONS

---

This digital apparatus does not exceed the Class A limits for radio noise emissions from digital apparatus as set out in the radio interference regulations of the Canadian Department of Communications.

Le présent appareil numérique n'émet pas de bruits radioélectriques dépassant les limites applicables aux appareils numériques de Classe A prescrites dans le règlement sur le brouillage radioélectrique édicté par le Ministère des Communications du Canada.

## RECYCLING LABEL



Note: On the instrument, the triangle background is yellow rather than gray.

This symbol is required in accordance with the Waste Electrical and Electronic Equipment (WEEE) Directive of the European Union. The presence of this marking on the product indicates:

- 1) the device was put on the European market after August 23, 2005 and
- 2) the device is not to be disposed via the municipal waste collection system of any member state of the European Union.

It is very important that customers understand and follow all laws regarding the proper decontamination and safe disposal of electrical equipment. For Beckman Coulter products bearing this label please contact your dealer or local Beckman Coulter office for details on the take back program that will facilitate the proper collection, treatment, recovery, recycling and safe disposal of the device.



# Specifications and Preinstallation Requirements

## SPECIFICATIONS

*Only values with tolerances or limits are guaranteed data. Values without tolerances are informative data, without guarantee.*

## CONTROL FEATURES

### Speed

Setting range	.0 to 25 000 rpm (in 10-rpm increments) or equivalent RCF (in $100 \times g$ increments)
Elutriation speed setting range	0 to 6 000 rpm (in 10-rpm or $10 \times g$ increments)
Speed display	from 0 to 10 000 rpm, indicates actual rotor speed $\pm 10$ rpm from 10 000 to 25 000 rpm, indicates actual rotor speed $\pm 0.1\%$ , or equivalent rcf

### Time

Setting range	.1 min to 99 hr 59 min, $\omega^2 t$ , or continuous (hold)
Actual display	indicates run time remaining (timed run), $\omega^2 t$ , or elapsed time (hold run)
$\omega^2 t$ setting range	up to $9.99 \times 10^{14}$ radians squared per second
$\omega^2 t$ actual display	indicates accumulated centrifugal effect to 3 significant digits (in exponential notation)

### Temperature

Setting range	-20 to +40°C (in 1°C increments)
Accuracy	rotor temperature controlled to within $\pm 2^\circ\text{C}$ of set temperature (after equilibration)*
Ambient temperature range	16 to 38°C (60 to 100°F)†
Cooling fluid	Refrigerant 404A (HFC)
Acceleration	maximum, slow, or timed (1 to 10 min from 0 to 500 rpm)
Deceleration	maximum, slow, timed (1 to 10 min from 500 to 0 rpm), or off



\* During transient conditions, such as acceleration and deceleration, rotor temperature may be outside this range.

† To reach temperatures above ambient, the centrifuge is dependent on the frictional heat generated inside the chamber during operation. At low run speeds or low ambient temperatures, the centrifuge may not be able to achieve some higher temperatures.

## OPERATIONAL FEATURES

---

Door	5.4-cm (2.1-in.) thick structural foam with steel plate
Rotor chamber diameter	40.6 cm (16 in.)
Friction Reduction System (FRS)	A mechanical rotary vane pump reduces chamber pressure to one-quarter atmosphere (190 mm [7.5 in.] Hg)

## PHYSICAL DATA

---

Width	71 cm (28 in.)
Depth	86 cm (34 in.)
Depth (including air diverter extending from back panel)	102 cm (40.25 in.)
Height, door closed	86 cm (34 in.)
Height to top of control head	116 cm (45.5 in.)
Height to top of open door	141 cm (55.5 in.)
Weight	264 kg (583 lb)
Clearances (for adequate ventilation)	
Sides	7.6 cm (3 in.)
Back (place air diverter against the wall)	16 cm (6.25 in.)
Surface finish	polyester control panel with polycarbonate coating overlay; polyurethane enamel on door and covers; vinyl paint on other surfaces
Maximum heat dissipation into room under steady-state conditions	6900 Btu/h (2.0 kW)
Humidity restrictions	<95% (noncondensing)
Noise level 0.91 m (3 ft) in front of instrument at 25 000 rpm	57 dBa
Installation category	II
Pollution degree	2

## AVAILABLE ROTORS

Refer to the applicable rotor manual for complete rotor descriptions.

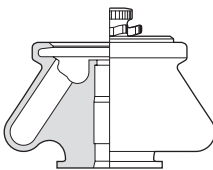
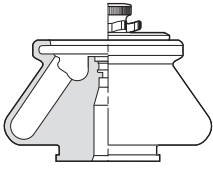
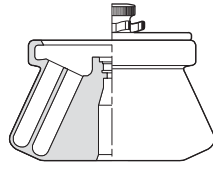
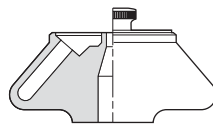
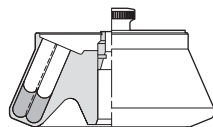
Rotor Profile and Description	Max RPM <sup>a</sup>	Max RCF (× g)	Max Capacity	Rotor Manual Number
JA-30.50 Ti Fixed Angle, 34° (8 place)  $r_{\max} = 108 \text{ mm}$	25 000 <sup>b</sup>	75 600	8 × 50 mL	J-TB-070
JA-25.50 Fixed Angle, 34° (8 place)  $r_{\max} = 108 \text{ mm}$	25 000	75 600	8 × 50 mL	J-TB-056
JA-25.15 Fixed Angle, 25° (24 place)  $r_{\max} = 106 \text{ mm}$ (outer row) $r_{\max} = 86 \text{ mm}$ (inner row)	25 000	74 200 (outer row) 60 200 (inner row)	24 × 15 mL	J-TB-057
JA-21 Fixed Angle, 40° (18 place)  $r_{\max} = 102 \text{ mm}$	21 000	50 400	18 × 10 mL	J-TB-002
JA-20.1 Fixed Angle, 23° (32 place)  $r_{\max} = 115 \text{ mm}$ (outer row) $r_{\max} = 98 \text{ mm}$ (inner row)	20 000	51 500 (outer row) 43 900 (inner row)	32 × 15 mL	J-TB-022

<sup>a</sup> Maximum speeds are based on a solution density of 1.2 g/mL with the following exceptions: the JA-18.1 rotor is rated for a density of 1.4 g/mL; the JCF-Z rotor is rated for a density of 1.45 g/mL; and the JE-6B rotor is rated for a density of 3 g/mL.

<sup>b</sup> Maximum speed for the JA-30.50 Ti rotor is 25 000 rpm in the Avanti J-25I centrifuge, and 30 000 rpm in the Avanti J-30I centrifuge.

<sup>c</sup> Maximum speed for the JS-24.38 and JS-24.15 rotors is 10 000 rpm in the Avanti J-25I centrifuge, and 24 000 rpm in the Avanti J-30I centrifuge.

—Continued

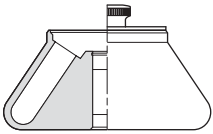
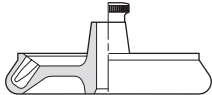
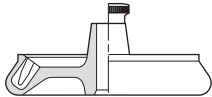
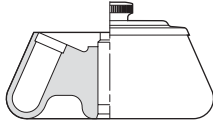
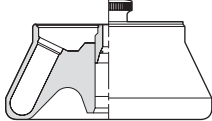
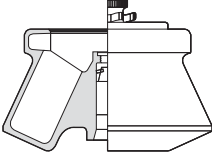
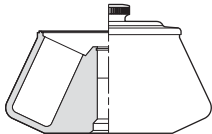

Rotor Profile and Description	Max RPM <sup>a</sup>	Max RCF (× g)	Max Capacity	Rotor Manual Number
JA-20 Fixed Angle, 34° (8 place)  $r_{\max} = 108 \text{ mm}$	20 000	48 400	8 × 50 mL	J-TB-003
JA-18.1 Fixed Angle (24 place)  45° adapter $r_{\max} = 116 \text{ mm}$  25° adapter $r_{\max} = 112 \text{ mm}$	18 000 17 000	42 100 36 300	24 × 1.8 mL	J-TB-037
JA-18 Fixed Angle, 23° (10 place)  $r_{\max} = 132 \text{ mm}$	18 000	47 900	10 × 100 mL	J-TB-035
JA-17 Fixed Angle, 25° (6 place)  $r_{\max} = 132 \text{ mm}$	17 000	39 800	14 × 50 mL	J-TB-017
JLA-16.250 Fixed Angle, 25° (6 place)  $r_{\max} = 134 \text{ mm}$	16 000	38 400	6 × 250 mL	J-TB-072
JA-14 Fixed Angle, 25° (6 place)  $r_{\max} = 137 \text{ mm}$	14 000	30 100	6 × 250 mL	J-TB-004

<sup>a</sup> Maximum speeds are based on a solution density of 1.2 g/mL with the following exceptions: the JA-18.1 rotor is rated for a density of 1.4 g/mL; the JCF-Z rotor is rated for a density of 1.45 g/mL; and the JE-6B rotor is rated for a density of 3 g/mL.

<sup>b</sup> Maximum speed for the JA-30.50 Ti rotor is 25 000 rpm in the Avanti J-25I centrifuge, and 30 000 rpm in the Avanti J-30I centrifuge.

<sup>c</sup> Maximum speed for the JS-24.38 and JS-24.15 rotors is 10 000 rpm in the Avanti J-25I centrifuge, and 24 000 rpm in the Avanti J-30I centrifuge.

—Continued

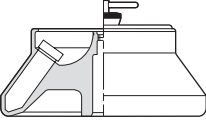
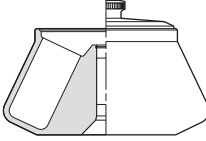
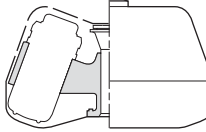
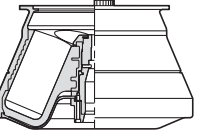
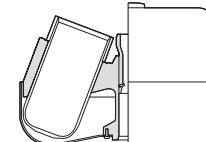
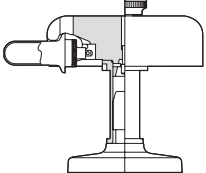
Rotor Profile and Description	Max RPM <sup>a</sup>	Max RCF (× g)	Max Capacity	Rotor Manual Number
JA-12 Fixed Angle, 35° (12 place)  $r_{\max} = 144 \text{ mm}$	12 000	23 200	12 × 50 mL	J-TB-051
JA-10 Fixed Angle, 25° (6 place)  $r_{\max} = 158 \text{ mm}$	10 000	17 700	6 × 500 mL	J-TB-006
JLA-10.500 Fixed Angle, 20° (6 place)  $r_{\max} = 166 \text{ mm}$	10 000	18 500	6 × 500 mL	J-TB-048
F10BCI-6x500y Fixed Angle, 23° (6 place)  $r_{\max} = 158 \text{ mm}$	10 000	17 696	6 × 500 mL	—
JLA-9.1000 Fixed Angle, 20° (4 place)  $r_{\max} = 185 \text{ mm}$	9 000	16 800	4 × 1000 mL	J-TB-073
JS-24.38 Swinging Bucket (6 place)  $r_{\max} = 161.0 \text{ mm}$	10 000 <sup>c</sup>	18 000	6 × 38.5 mL	J-TB-058

<sup>a</sup> Maximum speeds are based on a solution density of 1.2 g/mL with the following exceptions: the JA-18.1 rotor is rated for a density of 1.4 g/mL; the JCF-Z rotor is rated for a density of 1.45 g/mL; and the JE-6B rotor is rated for a density of 3 g/mL.

<sup>b</sup> Maximum speed for the JA-30.50 Ti rotor is 25 000 rpm in the Avanti J-2 I centrifuge, and 30 000 rpm in the Avanti J-30I centrifuge.

<sup>c</sup> Maximum speed for the JS-24.38 and JS-24.15 rotors is 10 000 rpm in the Avanti J-25I centrifuge, and 24 000 rpm in the Avanti J-30I centrifuge.

—Continued

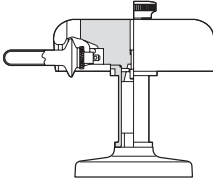
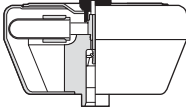
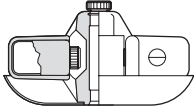
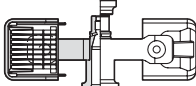
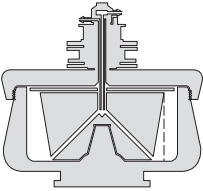
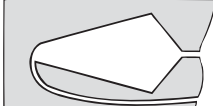
Rotor Profile and Description	Max RPM <sup>a</sup>	Max RCF (× g)	Max Capacity	Rotor Manual Number
<p>JS-24.15 Swinging Bucket (6 place)</p>  <p><math>r_{\max} = 171.3 \text{ mm}</math></p>	10 000 <sup>c</sup>	19 200	6 × 15 mL	J-TB-058
<p>JS-13.1 Swinging Bucket (6 place)</p>  <p><math>r_{\max} = 140 \text{ mm}</math></p>	13 000	26 500	6 × 50 mL	J-TB-036
<p>JS-7.5 Swinging Bucket (4 place)</p>  <p><math>r_{\max} = 165 \text{ mm}</math></p>	7 500	10 400	4 × 50 mL	J-TB-007
<p>JS-5.9 Swinging Bucket (2 place)</p>  <p><math>r_{\max} = 168.5 \text{ mm}</math></p>	5 900	6 570	10 microplates 4 deep-well plates 2 square-well plates	J-TB-092
<p>JCF-Z Continuous Flow/Zonal Rotor</p> 	20 000	—	660 mL (standard core) 1250 mL (large core) 240 mL (small core)	JCFZ-IM
<p>JE-6B Elutriation Rotor</p>  <p><math>r_{\max}</math> standard chamber = 125 mm Sanderson chamber = 126 mm</p>	6 000	5 040 5 080	4.2 mL (standard chamber) 4.8 mL (Sanderson chamber)	JE6B-IM

<sup>a</sup> Maximum speeds are based on a solution density of 1.2 g/mL with the following exceptions: the JA-18.1 rotor is rated for a density of 1.4 g/mL; the JCF-Z rotor is rated for a density of 1.45 g/mL; and the JE-6B rotor is rated for a density of 3 g/mL.

<sup>b</sup> Maximum speed for the JA-30.50 Ti rotor is 25 000 rpm in the Avanti J-251 centrifuge, and 30 000 rpm in the Avanti J-301 centrifuge.

<sup>c</sup> Maximum speed for the JS-24.38 and JS-24.15 rotors is 10 000 rpm in the Avanti J-251 centrifuge, and 24 000 rpm in the Avanti J-301 centrifuge.

## PREINSTALLATION REQUIREMENTS

*Do not attempt to install this instrument. Its purchase price includes installation by Beckman Coulter personnel. Installation by anyone other than an authorized Beckman Coulter representative invalidates any warranty covering the instrument.*

Preinstallation requirements have been sent prior to shipment of the instrument. The following information is provided in case the centrifuge must be relocated.

The centrifuge will be installed by a Beckman Coulter Field Service representative after preinstallation requirements for power and site preparation have been met. The following equipment is required for preinstallation:

- Voltmeter
- Single phase: two 30-ampere circuit breakers
- Three phase: three 16-ampere circuit breakers
- Power receptacle (see Figure 1-1 or 1-2)
- Drill for drilling holes in the floor for installation of anchoring kit bolts (see SECURING THE CENTRIFUGE TO THE FLOOR, later in this section). A 9.5 mm ( $3/8$ -inch) drill is required for concrete floors. A 6.4 mm ( $1/4$ -inch) drill is required for wood floors.

## ELECTRICAL REQUIREMENTS

---

Power to the centrifuge should originate directly from a main power line transformer at a power source known to be clear of erratic loads, spikes, and electromagnetic interference. Make sure that there are properly rated thermal circuit breakers at the service panel to protect the centrifuge circuit. If fuses must be used instead of the specified circuit breakers, the fuses may require a rating of greater than 30 Amperes (for single-phase centrifuges) or greater than 16 Amperes (for three-phase centrifuges).

Terminate the open end of the harmonized cord with a certified single- or three-phase connector suitable for the power supplied in the country of intended use (see Table 1-1). Install only one centrifuge per circuit.

To ensure safety, connect the instrument to a remote emergency switch (preferably outside the room where the centrifuge is housed, or adjacent to the exit from that room), in order to disconnect the centrifuge from the main power source in case of malfunction.

Table 1-1. Nominal Supply Voltage Ratings

Nominal Instrument Voltage Rating	Instrument Part Number	Instrument Part Number (Elutriation System)	Nominal Supply Frequency	Power Cord and Plug Description
Single-phase, 200/208/240 V	363106	363114	185–264 V, 50/60 Hz, 30 A	permanently attached three-wire UL/CSA-approved cord with NEMA type 6-30P plug
Single-phase, 230 V	363108	363116	185–264 V, 50 Hz, 30 A	permanently attached three-wire CENELEC harmonized cord without plug
Three-phase, 230/380 V + Neutral*	363109	363117	312–456 V plus neutral, 50 Hz, 16 A	permanently attached five-wire CENELEC harmonized cord without plug

\* Unbalanced three-phase. Split for single-phase operation internally.



**WARNING**

**To reduce the risk of electrical shock, this equipment uses a three-wire or five-wire electrical cord and plug to connect the centrifuge to earth-ground. To preserve this safety feature, make sure that the matching wall outlet receptacle is properly wired and earth-grounded.**

**Single and Three-Phase Power Connections**

Figure 1-1 shows the power connection for single-phase centrifuges, including earth-ground and two power leads with 30-ampere circuit breakers. Figure 1-2 shows the power connection for three-phase centrifuges, including earth-ground and three power leads with minimum 16-ampere circuit breakers and common neutral connection. Table 1-2 contains wiring information.

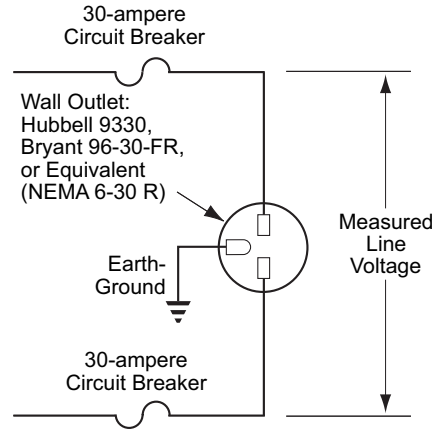

Figure 1-1. Single-Phase Electrical Requirements

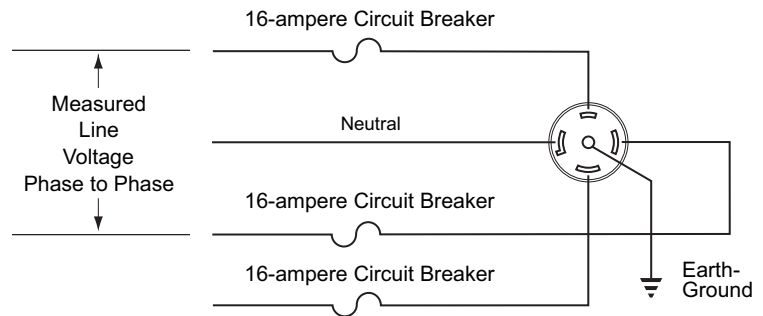

Figure 1-2. Three-Phase "Y" Electrical Requirements

Table 1-2. Required Wire Connections

Wire Insulation Color	Terminal	Symbol	
		Harmonized	North American
Green/Yellow	Earth ground		
Light Blue	Neutral	N	L
Brown	Live or Line	L	L
Black (three-phase connections only)	Live or Line (qty 2)	L	N/A

## Additional Requirements for Three-Phase Power Connections

---

For three-phase power service to the centrifuge, use the “Y” connected three-phase configuration shown in Figure 1-3. Also note the following information:

- The steady state current draw of the centrifuge can be as high as 12 amperes per phase, depending on the voltage.
- Inrush current to the centrifuge is 100 amperes for up to 2 seconds during the refrigeration start period. Circuit breakers, whether thermal or magnetic actuating, must be a “motor start” delay type.
- The centrifuge can tolerate a drop of 15 volts during the start period at low line voltage (see Figure 1-3 for the acceptable voltage ranges). The mains power for the centrifuge must be of sufficient wire gauge to provide this condition. The wire gauge required at a particular site must be determined by a facilities engineer at that site.

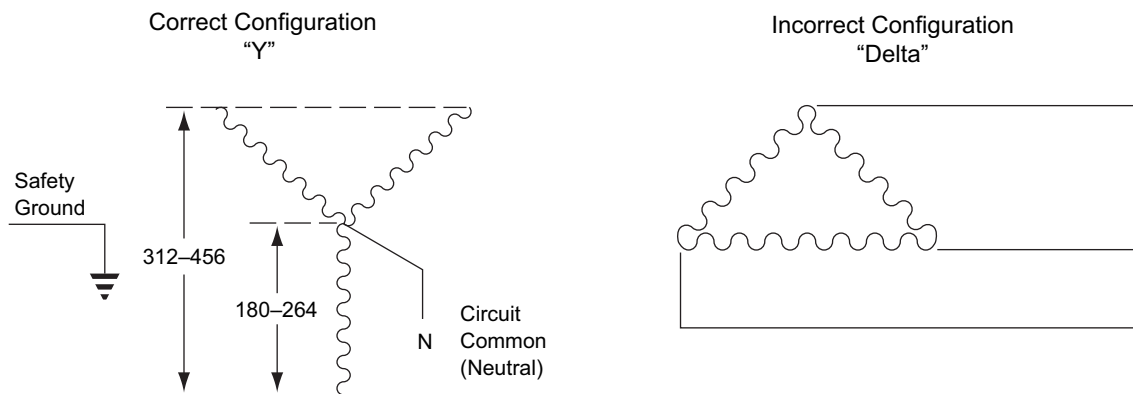

Figure 1-3. Correct and Incorrect Three-Phase Power Configurations

## SPACE AND LOCATION REQUIREMENTS

---

- Locate the instrument on a clean, level floor.
- Select a location away from heat-producing laboratory equipment. If ambient temperature exceeds 38°C (100°F), premature component failure may result.

- Allow a 7.7-cm (3-in.) clearance on each side of the instrument and a 16-cm (6.25-in.) clearance behind the instrument for air circulation. The centrifuge must have adequate air ventilation to ensure compliance to local requirements for vapors produced during centrifugation operation.

Position the centrifuge so that the air diverter, shown in Figure 1-4, touches the wall behind the centrifuge. Place the power cord to one side of the air diverter. To avoid damaging the power cord when installing or moving the centrifuge, be sure to move the cord out of the way before pushing the centrifuge against the wall.

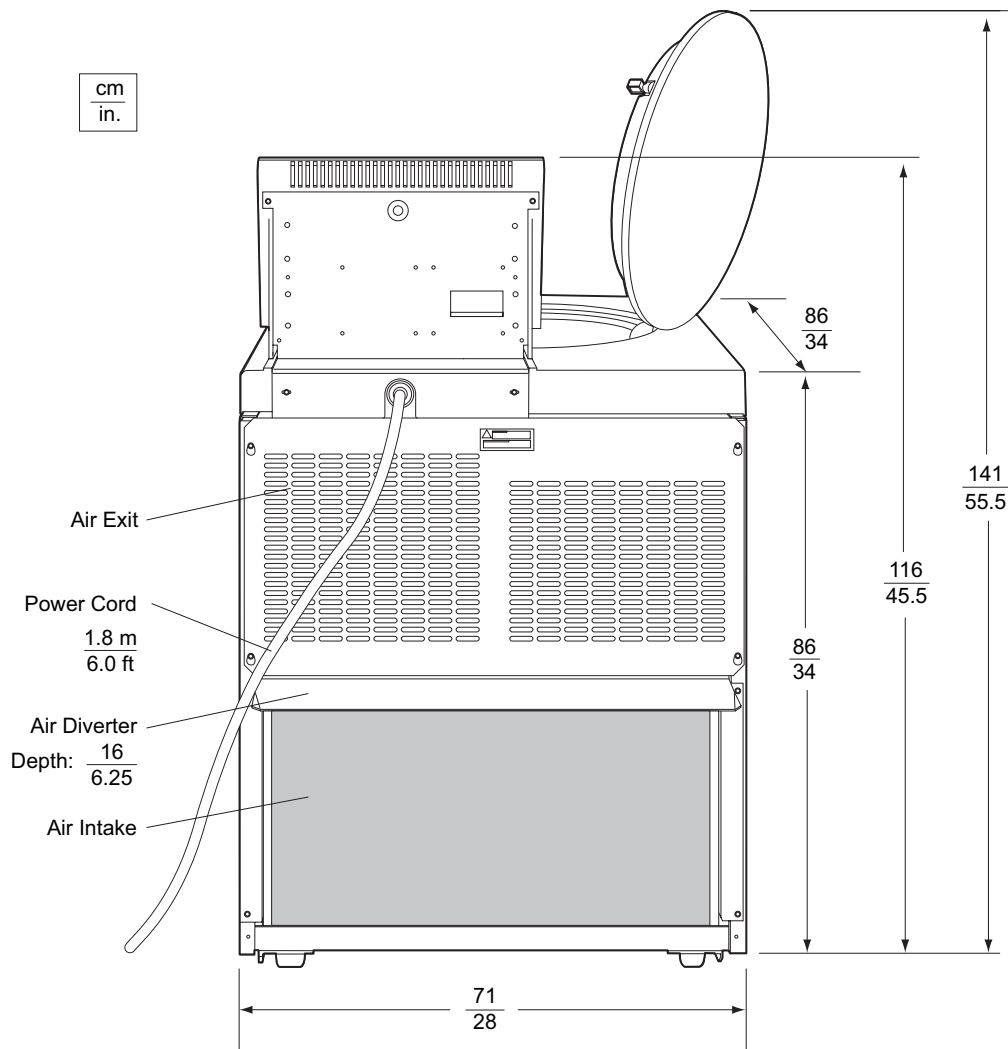

Figure 1-4. Rear View and Dimensions





**WARNING**

**Do not place the centrifuge near areas containing flammable reagents or combustible fluids. Vapors from these materials could enter the instrument's air system and be ignited.**

## SECURING THE CENTRIFUGE TO THE FLOOR

Avanti J series centrifuges are certified to meet the requirements of the European CE mark. To meet these requirements, the centrifuge must be secured to the floor using the anchoring hardware shipped with the instrument. This will prevent the centrifuge from moving in the unlikely event of a rotor mishap.

Complete instructions for installing the anchoring kit are packaged with the hardware, which is shipped with the centrifuge. The instructions (publication J325-TB-003) include a full-size template to be used as a guide for drilling holes in the floor. Refer to this document for additional installation instructions.



**NOTE**

Beckman Coulter representatives are not equipped to drill holes in your floor. The holes must be drilled *before* your scheduled installation.

## USING J2 SERIES ROTORS IN THE AVANTI J



**CAUTION**

*Do not use the Beckman Coulter JA-10, JS-7.5, JA-14, or JS-13 rotors in the Avanti J-251 centrifuge before reading this information.*

## CHECKING FOR ROTOR DRIVE PINS

Rotors used in Avanti J series centrifuges must have drive pins in the rotor drive hole (see Figure 1-5). These drive pins engage with the centrifuge spindle hub to ensure that the rotor does not slip during acceleration. Some Beckman Coulter rotors, including the JA-10, the JS-7.5, and the JA-14, were originally manufactured without drive pins because pins were not needed when these rotors were used in older model centrifuges.

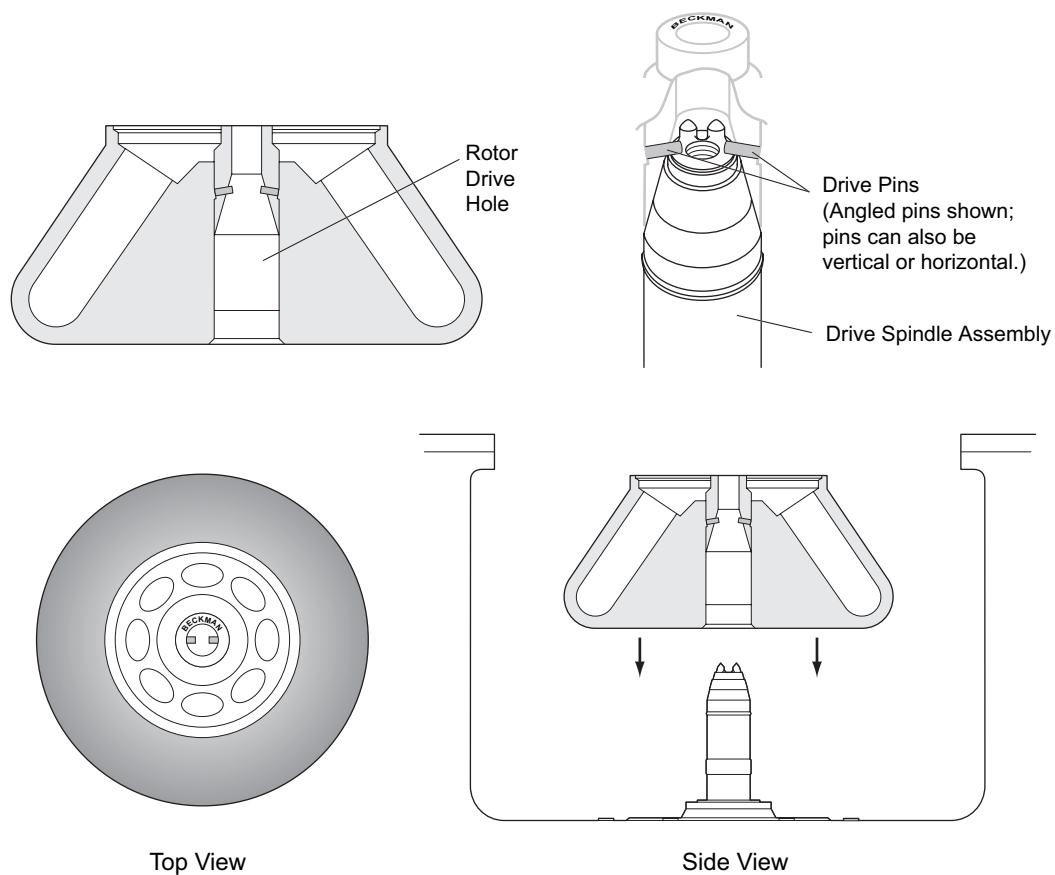

Figure 1-5. Checking the Rotor for Drive Pins

The rotor pins are positioned parallel to the BECKMAN name engraved at the center of the rotor body (see Figure 1-5). Knowing the pin orientation before you install the rotor will help to ensure that you position the rotor properly on the hub, minimizing the chance of hub damage.

*Check all J2 series rotors for drive pins, and do not use rotors without drive pins in the Avanti J. To check for drive pins, hold the rotor up or turn it on its side and look into the drive hole. If you do not see metal pins in the hole, do not use the rotor in the Avanti J. Call your local Beckman Coulter office for information on returning the rotor to the factory for upgrading.*

## **USING THE JA-18 ROTOR**

---

In Avanti J series centrifuges, the JA-18 rotor must be run with the lid attached. See the JA-18 rotor manual (document J-TB-035) for complete rotor usage instructions.

## **USING THE JCF-Z CONTINUOUS FLOW/ZONAL ROTOR**

---

### **Zonal Bracket Kits**

---

A special bracket and mounting hardware are required when the JCF-Z Continuous Flow/Zonal Rotor is used. These parts are contained in the Zonal Bracket Kit (part number 363843). Kit part number 363843 includes a bracket, mounting hardware, and assembly instructions. Kit 363843 is for use with Cole-Parmer tubing size 16 (6.4 mm [ $1/4$ -in.] O.D.), the tubing size most commonly used with the JCF-Z rotor.

Two additional kits are available, one which contains adapters for size 14 tubing (4.8 mm [ $3/16$ -in.] O.D.) and one which contains adapters for size 15 tubing (9.6 mm [ $3/8$ -in.] O.D.). If you wish to use either of these sizes of tubing, you will need to purchase one of these kits in addition to the basic kit (363843).

See REPLACEMENT PARTS AND SUPPLIES in Section 5 for a complete list of Zonal Bracket Kit part numbers and kit contents.

## Ensuring Correct JCF-Z Rotor Identification

---

The centrifuge's rotor identification system can, under two specific conditions, misidentify the JCF-Z continuous flow/zonal rotor. These conditions and corrective actions are listed below.

### NOTE

---

JCF-Z rotors manufactured after March, 1997, contain magnets that ensure correct rotor identification in Avanti J series centrifuges. We recommend that older JCF-Z rotors be returned to the Beckman Coulter factory for addition of the magnets before use in the Avanti J-25I. Call Beckman Coulter Field Service<sup>1</sup> for more information.

---

The following information pertains to JCF-Z rotors manufactured before March, 1997, and to JCF-Z rotors that have not been modified at the factory.

- When the bearings in the JCF-Z rotating seal assembly get old or worn, the resulting drag on the bearings changes the rotor's dynamic properties, making them similar to those of several Beckman Coulter fixed angle rotors. If rotor misidentification occurs when your JCF-Z rotor is used, first perform three runs from 0 to 5000 rpm and back to 0 rpm. If rotor misidentification recurs, replace the bearings. See the JCF-Z rotor instruction manual (publication JCFZ-IM) for bearing replacement instructions. Be sure to follow instructions in the next paragraph for wearing in the bearings.
- On the first few uses of a new JCF-Z rotor, or when the bearings have been replaced in an older JCF-Z rotor, lubrication has not yet been thoroughly distributed around the bearings in the bearing housing. The excess lubrication produces drag on the bearings, which can change the rotor's dynamic properties enough to cause rotor misidentification. To wear in the bearings and distribute the lubrication, perform three runs from 0 to 5000 rpm and back to 0 rpm.

### NOTE

---

If the JCF-Z rotor is misidentified, the run speed will be limited to the maximum speed for the identified rotor. (The maximum speed for the JCF-Z rotor is 20 000 rpm.)

---

---

<sup>1</sup> In the United States, call 1-800-742-2345. Outside the U.S., contact your local Beckman Coulter office.

## Description

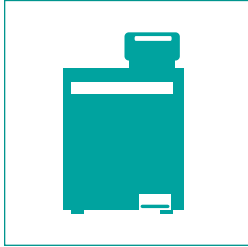

*This section describes the Avanti J-25 I centrifuge components and their functions. It also describes system safety features and centrifuge controls and displays. Refer to the applicable rotor manual for rotor description.*

## CENTRIFUGE FUNCTION AND SAFETY FEATURES

### CENTRIFUGE FUNCTION

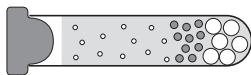
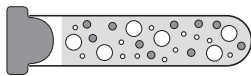

The Avanti J-25 I is a refrigerated centrifuge that generates centrifugal forces required for a wide variety of applications. Together with the Beckman Coulter rotors designed for use in this centrifuge, applications include:

- Routine processing such as sample preparations, pelleting, extractions, purifications, concentrations, phase separations, and spin column and spin filter centrifugations.
- Rapid sedimentation of protein precipitates, large particles, and cell debris.
- Preparation of subcellular organelles such as mitochondria, nuclei, and crude microsomes.
- Separation of blood cells and cellular components.
- Nucleic acid precipitation.
- Virus isolation.

- Bacteriophage isolation.
- Gradient separation, for example, Ficoll-Hypaque<sup>1</sup> and Percoll.<sup>1</sup>

The Avanti J-25I centrifuge is microprocessor-controlled, providing interactive operation.<sup>2</sup> The instrument design features a brushless switched-reluctance drive motor,<sup>3</sup> automatic rotor identification system, FRS (friction reduction system) vacuum control circuitry, temperature control system, and programmable acceleration and deceleration times.

The user interface consists of a separate Actual Value Display Setup Screen, a numerical keypad, and other system control and parameter entry touch keys. User messages and/or audible signals alert the operator to conditions that may need attention.

Manual and programmed operation are available.

- In manual operation, you enter the individual run parameters before beginning each run.
- In programmed operation, you enter and save sets of run parameters. To perform a run, you recall and start a previously saved program, enabling quick and accurate run duplication. Up to thirty programs can be saved, each containing one or two steps.

The centrifuge can also be operated by the SpinTrace™ II system for centrifuge control and data collection. SpinTrace II software runs on a personal computer connected to up to thirty-two centrifuges. Contact your Beckman Coulter representative for more information.

## SAFETY FEATURES

---

Safety features include the following.

- An electromechanical door lock system prevents operator contact with spinning rotors and prevents run initiation unless the door is closed and locked. The door locks when [ENTER] an [START] are pressed, or when the POWER switch is turned off. The exception to this is ZONAL mode, in which open-door operation up to 3000 rpm is allowed.

---

<sup>1</sup> Registered trademarks of Pharmacia AB.

<sup>2</sup> Avanti® J-25 I software and firmware © 1995 by Beckman Instruments, Inc., Palo Alto, CA

<sup>3</sup> Manufactured under license from Switched Reluctance Drives Limited, Harrogate, U.K.

- A steel casing surrounds the rotor chamber to provide operator protection in the unlikely event of a rotor mishap.
- *Dynamic Rotor Inertia Check (DRIC)*: As the rotor accelerates, rotor inertia is measured and the rotor energy is calculated for the speed set by the user. If the calculated rotor energy is determined to be excessive, the centrifuge recalculates a permitted set speed and uses this value to avoid possible rotor damage. A diagnostic message is displayed to indicate the change.
- An imbalance detector monitors the system during operation, causing automatic shutdown if rotor loads are severely out of balance.

## HOUSING AND DOOR

---



The instrument control housing is made of aluminum and molded structural foam. The door and structural-foam cover panels are finished with polyurethane enamel. The control panel is covered by a protective overlay made of coated polycarbonate.

The door is opened by stepping on a foot pedal located at the bottom right front of the instrument. The door is hinged at the back left to open at a 60-degree angle to the centrifuge side panels, providing clearance during loading and unloading of the centrifuge.

In the event of a power failure, the door lock can be manually unlocked for sample recovery (see Section 4, TROUBLESHOOTING).

## ROTOR CHAMBER

---

The rotor chamber is made of stainless steel to resist corrosion. A silicone rubber gasket around the chamber opening ensures sealing. (Instrument gaskets have *not* been qualified as bioseals for aerosol containment.)

## **DRIVE**

---

The drive spindle is directly driven by a brushless, high-torque, switched-reluctance drive motor. The instrument's resilient suspension minimizes disturbance of the sample during acceleration and deceleration, and reduces damage to the drive spindle if an imbalance occurs during centrifugation.

## **FRICTION REDUCTION SYSTEM (FRS)**

---

The friction reduction system (FRS) uses a mechanical rotary vane vacuum pump to reduce chamber pressure to approximately one-quarter atmosphere (190 mm Hg). The pump turns on after the run is started, before rotor friction reaches a high level. When the required vacuum level is reached, the pump turns off. Vacuum in the chamber is vented during rotor deceleration.

## **TEMPERATURE SENSING AND CONTROL**

---

The temperature control system, cooled by circulation of a non-CFC-based refrigerant, is activated when the centrifuge power is on and when the door is closed.

A thermistor in the rotor chamber continuously monitors the chamber temperature. The system calculates the chamber temperature required to maintain the set rotor temperature,  $\pm 2^{\circ}\text{C}$ .<sup>4</sup> Although the chamber temperature fluctuates during operation, the rotor's large mass keeps the sample temperature substantially constant. At the end of a run, the system continues controlling the temperature to prevent freezing or overheating of the sample.

---

<sup>4</sup> Refer to the applicable rotor manual for specific temperature information.



## OVERTEMP SYSTEM

---

An overtemp (over temperature) system provides flexibility, sample protection, and safety for the user.

- The user sets the run temperature, then sets a maximum temperature or accepts the default maximum temperature which is 4°C over the set temperature.
- The user specifies whether the run should shut down or continue if the overtemp setting is reached.
- The system will always shut down using maximum brake if the temperature goes above 45°C.

## NAME RATING PLATE

The name rating plate is affixed to the rear of the centrifuge. Always mention the model number and serial number when corresponding with Beckman Coulter regarding your centrifuge.

## CONTROLS AND INDICATORS

### POWER AND KEY SWITCHES

---

The power switch and the key switch are located below the control panel (see Figure 2-1).

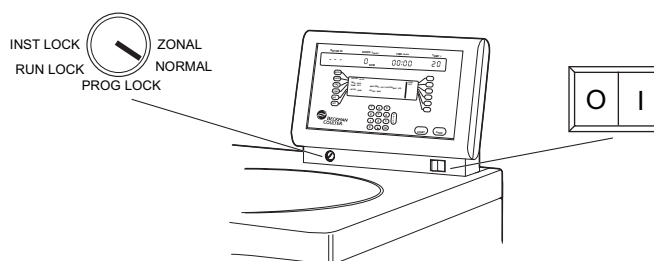

Figure 2-1. Power and Key Switches

The power switch is a two-position rocker switch (I, on; O, off) which controls electrical power to the centrifuge.

The key switch has five positions, indicating the five different operating modes.

- NORMAL mode is used for regular, closed-door centrifugation.
- ZONAL mode is used when the JCF-Z continuous flow/zonal rotor is installed. In ZONAL mode, the centrifuge can run up to 3000 rpm with the door open so that sample can be loaded and unloaded while the rotor is spinning.
- PROG(RAM) LOCK mode disables the function that saves parameters to stored programs, to prevent overwriting of previously stored programs.
- RUN LOCK mode disables all user inputs except [START] and [STOP] to ensure that current settings do not get changed.
- INST(RUMENT) LOCK mode disables all user inputs except [STOP], to prevent use of the instrument after the current run is complete.

## CONTROL PANEL

---

The control panel (Figure 2-2) is mounted at an angle on the centrifuge top rear for easy visibility and access. It contains a separate actual value display and a setup screen, numerical keypad, and touch keys for parameter entry and system control.

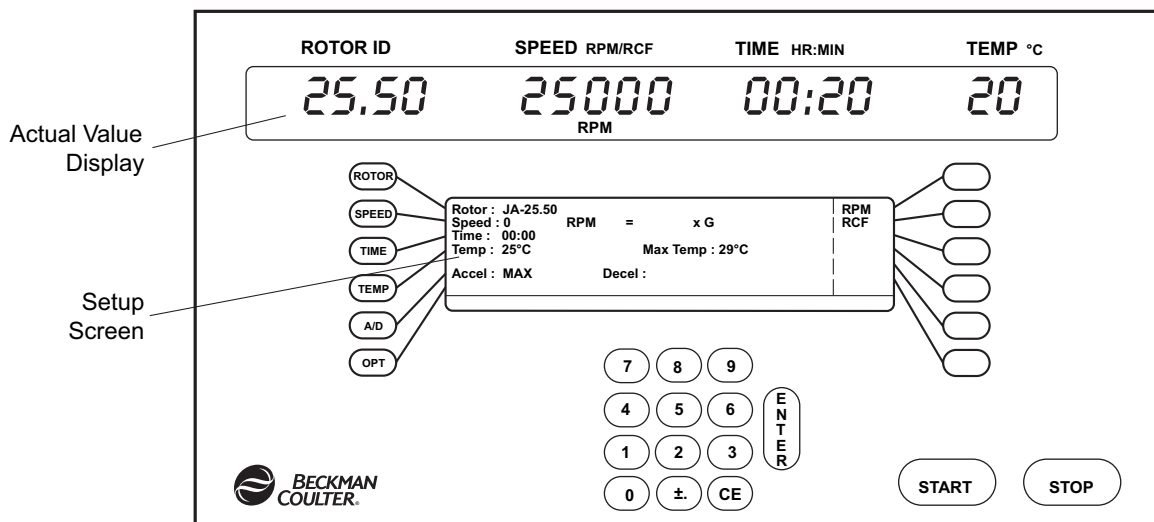

Figure 2-2. The Control Panel

## Actual Value Display

The actual value display (Figure 2-3) indicates the actual centrifuge operating conditions.

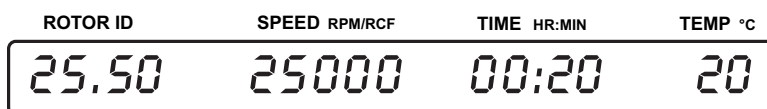

Figure 2-3. The Actual Value Display

### ROTOR ID

Indicates the installed rotor. At the start of a run, this field is blank. During acceleration, the centrifuge identifies the installed rotor and displays the rotor name.

### SPEED

Indicates rotor speed in revolutions per minute (rpm), or in relative centrifugal field, a term describing the ratio of the centrifugal acceleration at a specified radius and speed to the standard acceleration of gravity ( $RCF \times g$ ).

**TIME**

- In time mode, indicates the remaining run time in hours and minutes. The **TIME** display begins counting down when [**START**] is pressed and continues counting down to 0, when deceleration begins.
- In hold mode, indicates the time elapsed since [**START**] was pressed. After 99 hours and 59 minutes the timer will reset to 0 and continue counting elapsed time.
- In  $\omega^2t$  mode, indicates user-entered  $\omega^2t$  (accumulated centrifugal force on the sample) and the calculated time remaining until the  $\omega^2t$  setting is reached.

**TEMP °C**

Indicates rotor temperature in degrees C. The temperature is displayed to 1 degree and is within  $\pm 2$  degrees of the set temperature (after temperature equilibrium is reached).

**Setup Screen**

---

The setup screen (Figure 2-4) contains editable fields for parameter entry. The six function keys to the left of the screen are for selecting parameter fields. The six soft keys to the right of the screen are used to select options based on which function key is pressed. Guidelines direct the eye from each function and soft key to the display line controlled by that key. A message line at the bottom of the screen shows help, informational, and diagnostic messages during setup and operation.

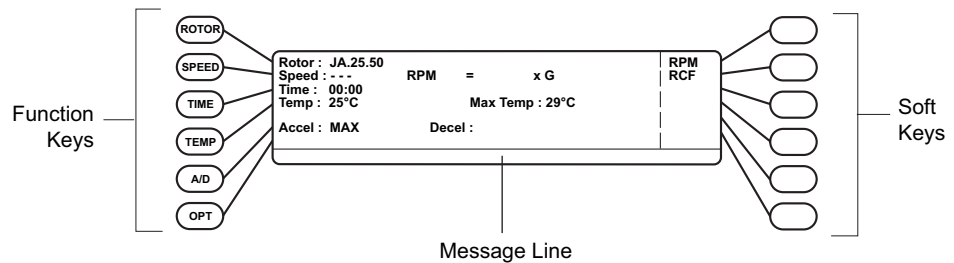

Figure 2-4. The Setup Screen

When the centrifuge power is turned on, the setup screen displays the parameters of the last run performed.

## Function Keys

---

Pressing [**ENTER**] or another function key saves parameter entries.

### [**ROTOR**]

Pressed to select the rotor in use. When [**ROTOR**] is pressed, the rotor type soft keys are displayed (JA: fixed angle rotors; JS: swinging bucket rotors; JLA: lightweight fixed angle rotors; JV: vertical tube rotors; JE: elutriation rotors; JCF-Z: continuous flow/zonal rotors). Pressing a rotor soft key displays a list of the rotors of that type that can be used. (Abbreviated rotor names are displayed.)

### [**SPEED**]

Pressed to enter a run speed, in rpm or  $\text{rcf} \times g$ . Use the RPM and RCF soft keys to toggle between rpm and rcf setting modes, then enter the speed setting using the keypad. If you enter a speed setting above the maximum rpm permitted for the installed rotor, a message will prompt you to select a speed within the rotor's valid range, and will display the range (in rpm or rcf).

If you start a run without selecting a rotor, and the speed setting is above the maximum for the installed rotor, during acceleration the centrifuge will identify the rotor and reduce the speed setting to the maximum for that rotor. A message will alert you to the change.

### [**TIME**]

Pressed to enter run time (using the keypad). When [**TIME**] is pressed, the last digit on the **TIME** display flashes, the three time modes appear in the soft key display area: HH:MM (hour:minute),  $\omega^2t$ , and HOLD.

- Timed run (HH:MM) — Run time up to 99 hours and 59 minutes can be set. If more than 59 minutes are entered in the minutes field, the system automatically converts the entry to hours and minutes. Deceleration begins when the set time counts down to zero. The corresponding  $\omega^2t$  value can be displayed by pressing the W2T soft key.
- $\omega^2t$  run — An  $\omega^2t$  value can be entered and the system will calculate the run time required to reach that value. Valid  $\omega^2t$  settings are different for each rotor; a message will appear if an invalid entry is made. Deceleration begins when the calculated run time counts down to zero, but  $\omega^2t$  continues accumulating until the rotor stops spinning.
- Continuous run (Hold) — For runs of unspecified lengths, hold mode is used. The display will show the accumulated run time. When 99 hours, 59 minutes is reached, the system resets to 0 and continues counting. The run will continue until the [**STOP**] key is pressed.

[TEMP]

Pressed to enter run temperature (using the keypad), from  $-20^{\circ}\text{C}$  to  $+40^{\circ}\text{C}$ .

- The minimum allowable set temperature depends on the set speed and the rotor in use. If a temperature is entered that cannot be achieved by the rotor at the set speed, the TEMP $^{\circ}\text{C}$  field will flash.
- The maximum achievable rotor temperature depends on the frictional heat generated inside the chamber during operation. At low run speeds or low ambient temperature, the centrifuge may not be able to achieve some higher temperatures.
- If, during acceleration, the system identifies a rotor different from the rotor entered by the user, or if the set speed is changed during operation, the set temperature may no longer be achievable. If this happens, the Temp $^{\circ}\text{C}$  field will flash indicating that a different temperature must be entered.

[A/D]

Pressed to enter acceleration and deceleration rates that will maintain optimum separation while protecting samples. When [A/D] is pressed, the **Accel:** field flashes, prompting you to enter an acceleration setting. Pressing [A/D] once more moves the cursor to the **Decel:** field.

Available acceleration rates are maximum, slow, and timed (1 to 10 minutes from 0 to 500 rpm). Available deceleration rates are maximum, slow, timed (1 to 10 minutes from 500 to 0 rpm), and no brake (off).

[OPT]

Pressed to put the centrifuge into program mode, where you can enter run parameters into memory for later use. Up to thirty two-step programs can be stored.

## KEYPAD

---

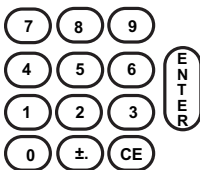

The keypad is used to enter numerical run parameters and to enter program numbers. In addition to keys 0 through 9, the keypad includes [±.] (plus/minus/decimal) and [CE] (clear entry) keys.

The [±.] key is used to enter a decimal point when typing in a rotor number (for example, 25.50) and to enter a temperature setting below  $0^{\circ}\text{C}$  (for example,  $-2^{\circ}\text{C}$ ).

The [CE] (clear entry) key clears any parameter in the active field. Pressing [CE] will also clear some diagnostic messages. If a diagnostic message does not clear when [CE] is pressed, see Section 4, TROUBLESHOOTING.

## SYSTEM KEYS

---

- [START]** Pressing **[ENTER]**, then **[START]** begins the run. (**[START]** must be pressed within 5 seconds of pressing **[ENTER]**.) This key combination can also be used to abort a deceleration process and restart the centrifuge.
- [STOP]** Pressed to end a run according to the deceleration setting. The red light on the **[STOP]** key flashes while the rotor decelerates. An audible tone sounds when the rotor comes to a complete stop. Deceleration can be terminated and the centrifuge restarted by pressing **[ENTER]**, then **[START]**.
- During a zonal run, pressing **[STOP]** once will decelerate the rotor to 2000 rpm. Pressing **[STOP]** again will decelerate the rotor to 0 rpm.
- [ENTER]** Pressed to save parameter entries to system memory, and to start the centrifuge. (**[ENTER]**, then **[START]** must be pressed to start the centrifuge.)

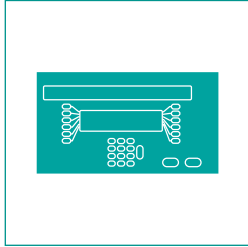

*This section contains detailed centrifuge operating procedures. A summary is provided at the start of this section. If you are an experienced user of this centrifuge, you can turn to the summary for a quick review of operating steps.*



## **WARNING**

---

Normal operation may involve the use of solutions and test samples that are pathogenic, toxic, or radioactive. Handle body fluids with care because they can transmit disease. No known test offers complete assurance that they are free of micro-organisms. Some of the most virulent—Hepatitis (B and C) and HIV (I–V) viruses, atypical mycobacteria, and certain systemic fungi—further emphasize the need for aerosol protection. Handle other infectious samples according to good laboratory procedures and methods to prevent spread of disease. Because spills may generate aerosols, observe proper precautions for aerosol containment. Do not run toxic, pathogenic, or radioactive materials in this centrifuge without taking appropriate safety precautions. Biosafe containment should be used when Risk Group II materials (as identified in the World Health Organization *Laboratory Biosafety Manual*) are handled; materials of a higher group require more than one level of protection.

Do not use the centrifuge in the vicinity of flammable liquids or vapors, and do not run such materials in the centrifuge. Do not lean on the centrifuge or place items on it while it is operating.

---



## SUMMARY OF RUN PROCEDURES

For runs at other than room temperature, precool or prewarm the rotor to the required temperature before the run.

### MANUAL RUN

---

1	Press the POWER switch to on (I).
2	Depress the foot pedal to open the chamber door.
3	Install the rotor according to instructions in the applicable rotor manual, then firmly close the chamber door.
4	Press [ROTOR], press the soft key to select rotor type, press the soft key to select the rotor name.
5	Press [SPEED], press the soft key to select RPM or RCF mode, then use the keypad to enter the run speed (0 to 25 000 rpm).
6	Press [TIME], press the soft key to select a time mode (HH:MM, Hold, or $\omega^2t$ ), then use the keypad to enter the run time or $\omega^2t$ value. (No entry is made in Hold mode.)
7	Press [TEMP], then use the keypad to enter the required run temperature.
8	Press [A/D] and press the MAX, SLOW, or TIME soft key. Or, skip this step and accept the default acceleration rate (SLOW for the JS-24.38 and JS-24.15 rotors; MAX for all other rotors).
9	Press [A/D] and press the MAX, SLOW, TIME, or OFF soft key. (Or, skip this step and accept the default deceleration rate (SLOW for the JS-24.38 and JS-24.15 rotors; MAX for all other rotors).
10	Check that all parameters are correct and that the door is closed. Press [ENTER], then press [START].
11	Wait for the set time to count down to zero, or end the run by pressing [STOP].
12	When the rotor stops, depress the foot pedal to open the chamber door.

## PROGRAMMED RUN

---

1	Press the POWER switch to on (I).
2	Depress the foot pedal to open the chamber door.
3	Install the rotor according to instructions in the applicable rotor manual, then firmly close the chamber door.
4	Press [OPT], then use the keypad to enter the program number.
5	Check that all parameters are correct and that the door is closed. Press [ENTER], then press [START].
6	Wait for program step 1 or 2 to end, or end the run by pressing [STOP].
7	When the rotor stops, depress the foot pedal to open the chamber door.

## PREPARATION

Prepare the rotor for centrifugation as described in the rotor manual.

## INSTALLING THE ROTOR

---

The power must be turned on before you can unlock and open the chamber door.

### Action

---

1. Turn the power switch on (I).
2. Depress the foot pedal to open the door.

### Result

---

Indicator lights on the control panel light up.

The door opens.

## Action

---

3. Install the rotor according to the instructions in the rotor manual. Make sure that the rotor is seated on the drive hub.

4. Securely attach the rotor lid knob, or tie-down knob in rotors without lids, to the drive shaft by turning it to the right (clockwise).

5. Close the chamber door.

## Result

---



### CAUTION

---

*Do not drop the rotor onto the drive hub. The drive spindle can be bent if the rotor is forced sideways or dropped onto the spindle hub. Install the rotor by centering it over the hub and carefully lowering it straight down.*

---



### NOTE

---

If the knob turns loosely and you do not feel threads engaging, the rotor drive hole pins may not be properly seated on the centrifuge hub. Lift the rotor up, rotate it slightly, and lower it onto the hub again. Tighten the knob.

---



### CAUTION

---

*If you leave the rotor in the centrifuge between runs, make sure the rotor is seated on the drive hub and the tie-down knob is tight before each run.*

---

## MANUAL OPERATION

- When a function key ([**ROTOR**], [**SPEED**], [**TIME**], [**TEMP**], [**A/D**], or [**OPT**]) is pressed, the corresponding setup screen field blinks to indicate that a parameter can be entered or changed. The field continues to blink until [**ENTER**] or another function key is pressed.
- To change an entry before you've pressed [**ENTER**], press [**CE**] and enter a different value. To change an entry after you've pressed [**ENTER**], press the function key again.
- If an invalid setting is entered, the display blinks and the valid range for that parameter is displayed in the message line. A valid parameter must be entered and [**ENTER**] must be pressed before you can enter another parameter.

## SELECTING A ROTOR

### Action

1. Press [ROTOR].

2. Press the appropriate soft key to select the rotor type.

To select a different rotor type, press [ROTOR] again and then press another soft key.

3. Select the rotor name by pressing the appropriate soft key. Press [ENTER].

### Result

The **Rotor:** field flashes, and rotor type abbreviation soft keys (JA: fixed angle, JS: swinging bucket, JLA: lightweight fixed angle; JV: vertical tube rotors; JE: elutriator rotors; JCF-Z: continuous flow/zonal) appear.

A list of rotors of the selected type appears—fixed angle rotors are displayed below. Press the MORE soft key to display additional fixed angle rotor names.

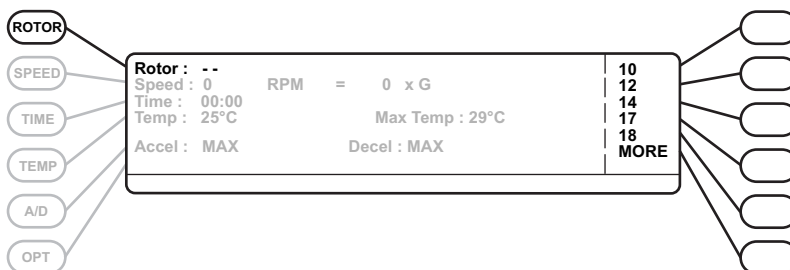

The selected rotor name appears in the **Rotor:** field.

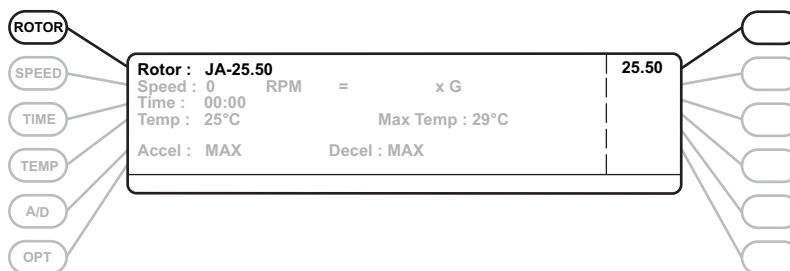

## ENTERING RUN SPEED

Enter a run speed up to the maximum speed of the rotor in use (25 000 rpm maximum). Or, enter a relative centrifugal field (rcf) value up to the maximum achievable rcf of the rotor.

## Entering RPM

### Action

1. Press [SPEED].

### Result

The **Speed:** field flashes, and RPM and RCF soft keys appear. The RPM indicator illuminates in the actual value display.

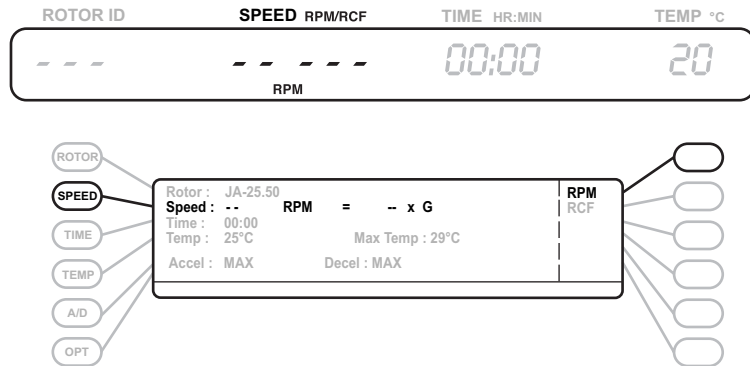

2. Enter the required rpm on the keypad and press [ENTER].

The speed is displayed in the **Speed:** field. The system rounds off the last digit of the rpm entry, if necessary, and calculates and displays the *g*-force applied to the rotor at that speed.

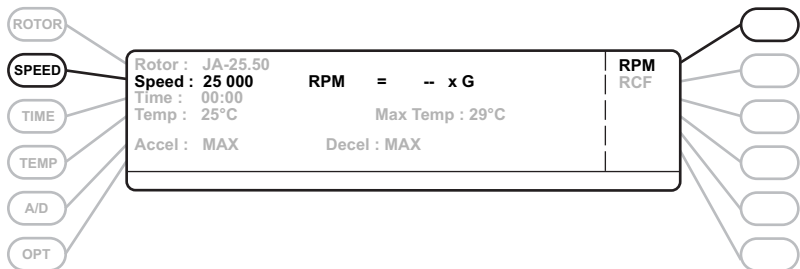

## Entering RCF

### Action

1. Press [SPEED].

### Result

The **Speed:** field flashes, and the RPM and RCF soft keys appear.

**Action**

2. Press the RCF soft key.

**Result**

The RPM = - - × G field flashes.

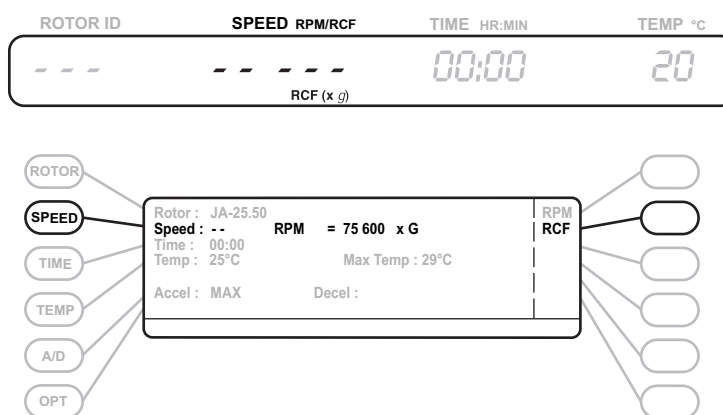

3. Enter the required rcf on the keypad and press [ENTER].

The rcf and the corresponding rpm appear in the **Speed:** field. The RCF (× g) indicator illuminates on the actual value display, indicating that rcf (× g) is being displayed during the run. When [ENTER] and [START] are pressed, the centrifuge runs at the calculated rpm.

If you enter an rcf value that is unachievable for the installed rotor, a message will appear telling you the rotor's achievable rcf range.

**ENTERING RUN TIME**

Run time can be entered in hours and minutes or in  $\omega^2t$  (accumulated centrifugal effect). Hold mode is used for continuous operation.

**Entering a Timed Run****Action**

1. Press [TIME].

**Result**

HH:MM, W2T, and HOLD soft keys appear.

**Action**

2. Use the keypad to enter the required time (up to 99 hours, 59 minutes) and press [ENTER].

**Result**

Entered time appears in the **Time:** field.

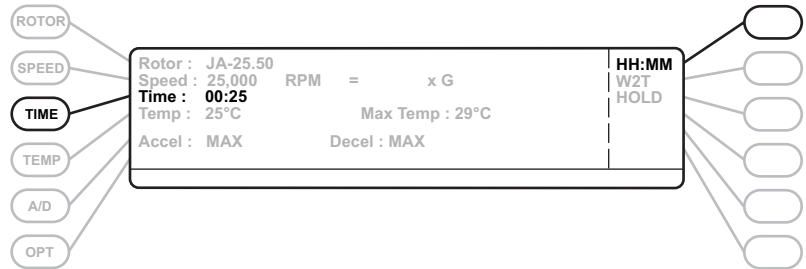

3. Press the next function key or press [ENTER], then [START].

The run begins, and the time remaining begins counting down to 0 in the **TIME** display. If you enter a number over 59 minutes, the centrifuge automatically recalculates the time in hours and minutes after [ENTER] or any function key is pressed.

Deceleration begins when the **TIME** display has counted down to 0. During deceleration, “End” flashes in the **TIME** display and the red indicator light on the [STOP] key flashes.

**Entering an  $\omega^2t$  Run**

**Action**

1. Press [TIME].
2. Press the W2T soft key to select the  $\omega^2t$  mode.
3. Use the keypad to enter an  $\omega^2t$  value.

**Result**

HH:MM, W2T, and HOLD soft keys appear.

The  $\omega^2t$  indicators (EXP 00 and rad<sup>2</sup>/sec) light in the **TIME** display.

The entry appears in the **Time:** field. The decimal point and E appear automatically as you type. If you enter a value out of the achievable  $\omega^2t$  range for that rotor, a message prompts you to enter a different value.

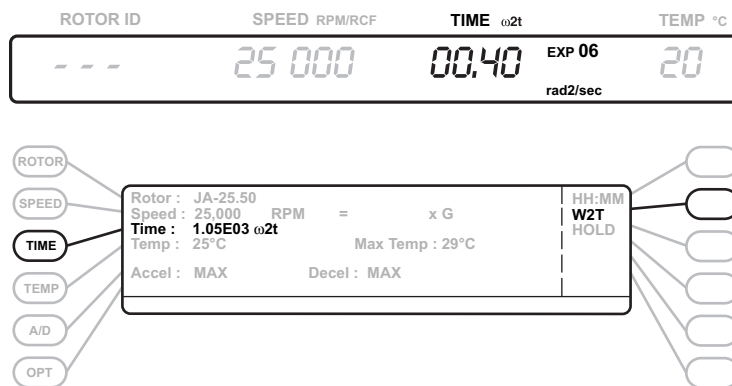

**Action**

4. Press the next function key or press [ENTER], then [START].

**Result**

The centrifuge begins calculating and displaying the accumulated centrifugal effect.

Deceleration begins when the set  $\omega^2t$  value is reached. During deceleration, the red indicator light on the [STOP] key flashes. The  $\omega^2t$  continues to accumulate until the rotor stops spinning, so set and actual  $\omega^2t$  values may be different at the end of the run.

**Entering a Continuous (HOLD) Run**

**Action**

1. Press [TIME].
2. Press the HOLD soft key to select the hold mode.

**Result**

The HH:MM, W2T, and HOLD soft keys appear.

HOLD appears in the **Time:** field.

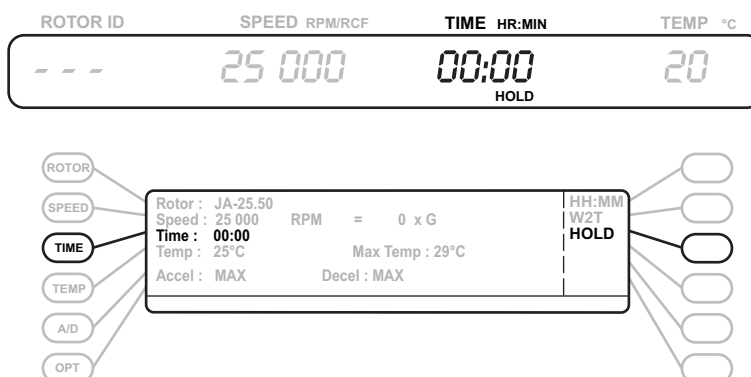



**Action**

3. Press the next function key or press [ENTER], then [START].

**Result**

After you start the run, the HOLD indicator illuminates in the **TIME** display. The elapsed run time is displayed. The run continues until [STOP] is pressed.

**ENTERING RUN TEMPERATURE**

Run temperature can be set from -20 to +40°C. If no value is entered, the last-entered temperature is used.

**Action**

1. Press [TEMP].

**Result**

The **Temp:** field flashes.

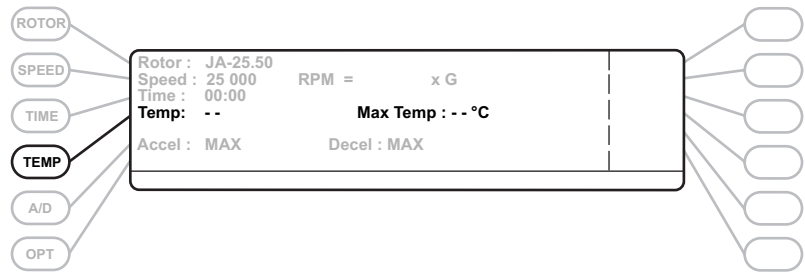

2. Use the keypad to enter the required temperature.

Entered temperature appears in the **Temp:** field.

3. Press the [TEMP] key again to move the cursor to the **Max Temp:** field.

Entered temperature plus 4°C appears in the **Max Temp:** field, and YES and NO soft keys appear. The default maximum temperature is the set temperature plus 4°C. You can specify a different maximum temperature, from +2°C above the set temperature to 44°C. You can also specify whether or not you want the system to shut down if the maximum temperature is reached. The centrifuge will always shut down if the system temperature reaches 45°C.

4. Use the keypad to enter a different maximum temperature, or accept the default.

**Action**

- Choose YES to make the system shut down at maximum temperature, or NO to allow the system to run above maximum temperature.

**Result**

Your selection (YES or NO) appears to the right of the **Max Temp:** field.

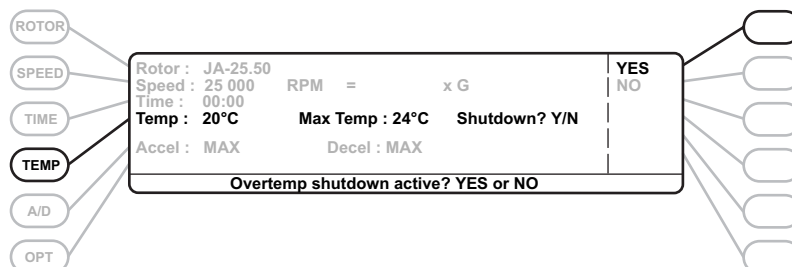

**ENTERING ACCELERATION AND DECELERATION RATES**

The centrifuge provides a choice of three acceleration rates and four deceleration rates to protect the gradient and sample-to-gradient interface. Table 3-1 describes these rates. If no rate is selected, the centrifuge accelerates and decelerates at maximum rates.

Table 2-1. Acceleration and Deceleration Settings

Setting	Description
Maximum acceleration	Full torque is used from 0 rpm until set speed is reached.
Slow acceleration	Approximately 2 minutes from 0 to 500 rpm. (The exact time depends on the mass of the rotor in use; larger rotors take longer.) Above 500 rpm, full torque is used until set speed is reached.
Timed acceleration	From 0 to 500 rpm, acceleration can be set from 1 to 10 minutes Above 500 rpm, full torque is used until set speed is reached.
Maximum deceleration	Full brake from set speed to near 0 rpm. Reduced brake is used during the last few rpm until 0 is reached to minimize sample disturbance.
Slow deceleration	Reduced torque from set speed to 500 rpm, then approximately 2 minutes from 500 to 0 rpm. Deceleration to 500 rpm takes about twice as long as with maximum deceleration. (The exact time depends on the mass of the rotor in use; larger rotors take longer.)
Timed deceleration	Full brake from set speed to 500 rpm. From 500 to 0 rpm, deceleration can take from 1 to 10 minutes (time is set by the user).
Off	No brake is used. Rotor coasts from set speed to 0 rpm. Can take up to 1 hour, depending on the mass of the rotor in use and the set speed.

The default setting for both acceleration and deceleration is maximum (MAX) for all rotors except the JS-24.38 and the JS-24.15. SLOW is the default setting for these rotors; TIMED settings can also be used.

## Acceleration

---

### Action

1. Press [A/D].
2. Press the appropriate soft key.

### Result

The **Accel:** field flashes. MAX, SLOW, and TIME soft keys appear.

If you choose MAX or SLOW, your selection appears in the **Accel:** field. If you choose TIME, enter an acceleration time from 1 to 10 minutes and press [A/D] again or accept the 10-minute default setting.

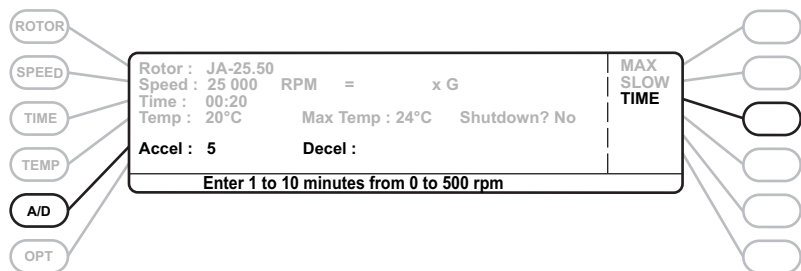

## Deceleration

---

### Action

1. Press [A/D] twice (if the cursor is in the **Accel:** field, press [A/D] once).

### Result

The **Decel:** field flashes. MAX, SLOW, TIME, and OFF soft keys appear.

**Action**

2. Press the appropriate soft key.

**Result**

If you choose MAX, SLOW, or OFF, your selection appears in the **Decel:** field. If you select TIME, enter a deceleration time and press [A/D] again or accept the 10-minute default setting.

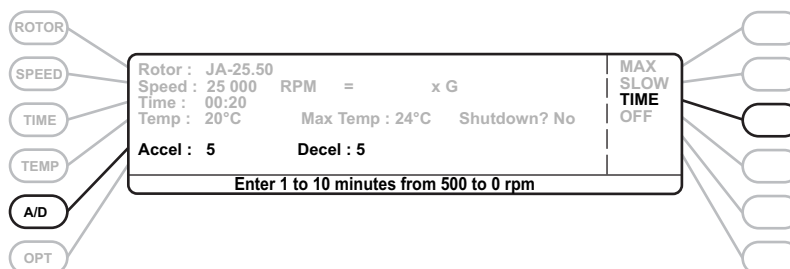
**STARTING A RUN****Action**

1. Press [ENTER], then [START]. (You must press [START] within 5 seconds of pressing [ENTER].)

**Result**

The green light on the [START] key flashes and the rotor begins to spin.

**CHANGING PARAMETERS DURING A RUN**

While a run is in progress, run parameters (speed, time, temperature, and acceleration and deceleration settings) can be changed without stopping the run by entering the new setting and pressing [ENTER].

**ENDING A RUN**

To end a run in progress, press [STOP]. The red [STOP] indicator light flashes until the rotor comes to a complete stop.

In timed runs, deceleration begins automatically when the **TIME** display counts down to zero. In  $\omega^2 t$  runs, deceleration begins when the set  $\omega^2 t$  value is achieved.

**NOTE**

If a diagnostic condition causes the run to stop, a diagnostic message appears and the red [STOP] indicator light flashes until the rotor comes to a complete stop. See Table 4-1 for diagnostic code explanations and troubleshooting procedures.

## PROGRAMMED OPERATION

The centrifuge internal memory can store up to thirty programs, each containing up to two steps (each step is a set of run parameters). Programs are retained in memory when the power is turned off.

### CREATING A NEW PROGRAM

**Action**

1. Press [OPT].
2. Press [OPT] again to move the cursor to the **Setup:** field. Use the keypad to enter a program number in this field.

**Result**

Default system parameters appear, the **Prog(ram) Recall:** field flashes, and the message line says “Enter program number (1–30).”

A two-step program is created and is assigned the number you entered. If you enter a number that is already assigned to a program, you can either overwrite the program or select another program number.

A message prompts you to enter parameters for step 1.

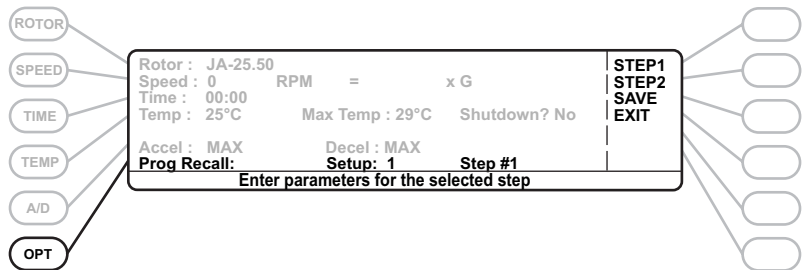

**Action**

3. Enter run parameters (rotor, speed, time, temperature, acceleration/deceleration settings) for step 1. Press [ENTER] when programming is complete.

**Result**

The message “Switch steps, save, or exit program mode” appears.

**NOTE**

To program a delayed start, set the time in step 1 to the required delay length and set the speed in step 1 to 0 rpm. Enter run parameters in step 2, setting the step 2 time to any value greater than 00:00. The run will start when the step 1 set time has elapsed.

4. If you want to program one step only, press the SAVE soft key, then press the EXIT soft key to exit program mode.

The parameters are saved to step 1.

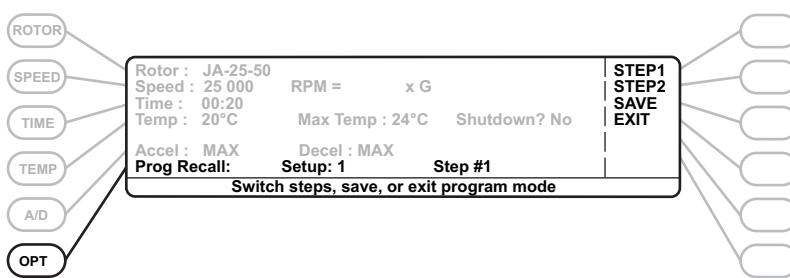

If you are overwriting a program that contains user-entered settings in step 2, those values are retained until you change them. To check step 2 settings, press the STEP2 soft key.

5. To add a second step to program 1, press the STEP2 soft key.

6. Enter parameters for step 2. Press [ENTER] when done.

All parameters for step 1 and 2 are saved under the selected program number.

To recheck the parameters in either step, press the STEP1 or STEP2 soft key to toggle to that step.

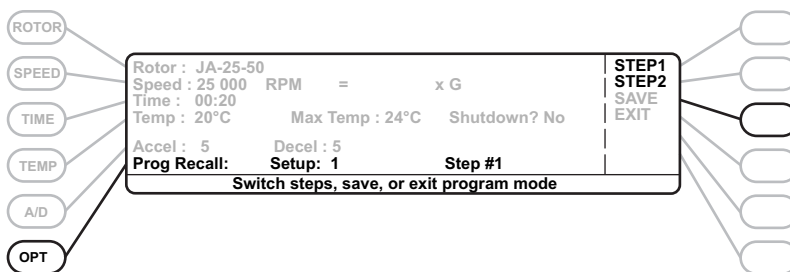

**Action**

7. Press the SAVE soft key when programming is complete.
8. Press the EXIT soft key to exit program mode.

**Result**

The program is saved.

**MODIFYING A PROGRAM**

**Action**

1. Press the [OPT] key.
2. Press [OPT] again to move the cursor to the **Setup:** field. Enter the number of the program to be modified.

**Result**

The **Prog Recall:** field flashes, and the message “Enter program number (1–30)” appears.

The program number appears in the **Setup:** field. A message appears asking if you want to overwrite the program. YES and NO soft keys appear.

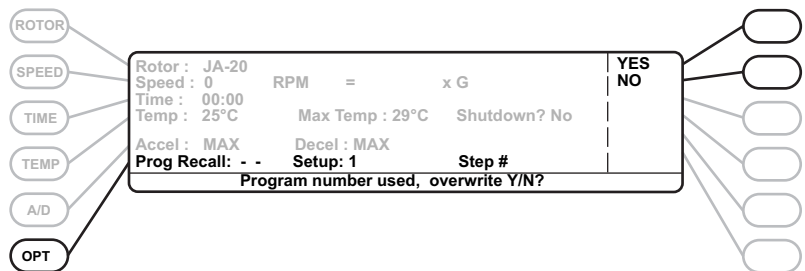

3. Press the YES soft key.
4. To see step 2 parameters, press the STEP2 soft key.
5. Modify the parameters for either step. Press [ENTER] when done. Repeat for the other step, if required.

The step 1 parameters appear.

The step 2 parameters appear.

The newly entered parameters appear.

**Action**

6. Press the SAVE soft key to save both program steps.

**Result**

Steps 1 and 2 are saved under the selected program number.

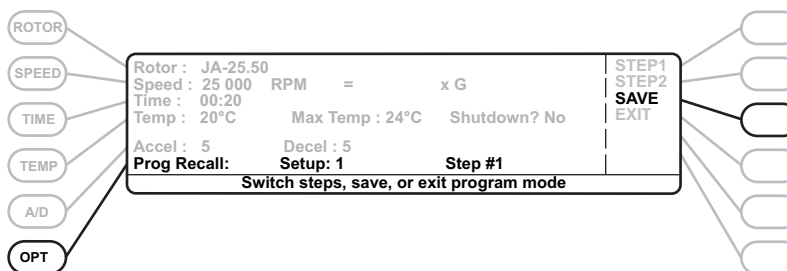

7. Press the EXIT soft key to exit program mode.

**RUNNING A PROGRAM**

**Action**

1. Press [OPT].
2. Use the keypad to enter the program number in the **Prog Recall:** field.
3. Press [ENTER], then [START].

**Result**

The **Prog Recall:** field flashes.

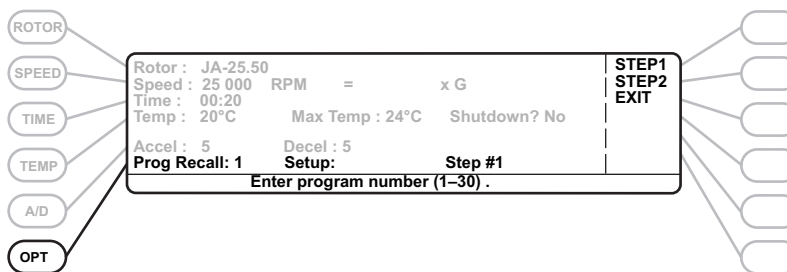

**SETTING UP A ZONAL RUN**

When the centrifuge is in the zonal mode (key switch is in the ZONAL position), open-door operation at speeds up to 3000 rpm is permitted to allow loading and unloading of the rotor while it is spinning.

*The JCF-Z continuous flow/zonal rotor is the only rotor that can be used while the key switch is in the ZONAL position. See the JCF-Z rotor manual for complete rotor operating instructions.*



**Action**

1. Turn the key to the ZONAL position.

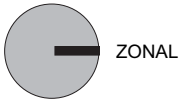

2. Install the rotor. Leave the door open when installation is complete.
3. Press [ROTOR]. Press the JCF-Z soft key. Enter the remaining run parameters.

**Result**

Open-door operation up to 3000 rpm is enabled. JCF-Z appears in the **Rotor:** field.

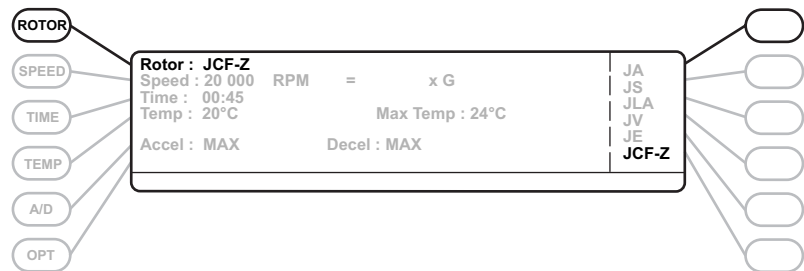
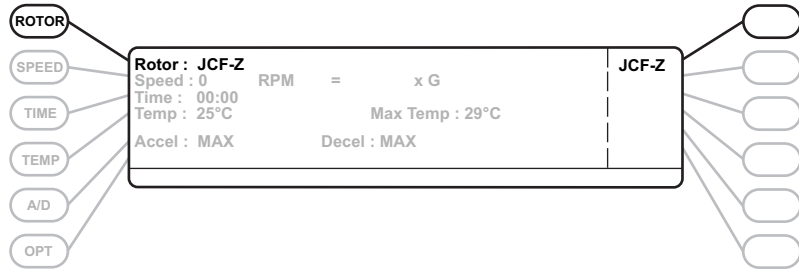

4. Press [ENTER], then [START].
5. Load the rotor.
6. Close the door.
7. End the run.

The rotor begins accelerating to 2000 rpm, which is the default loading speed. To select a different loading speed, enter a speed of 3000 rpm or less before or after the rotor starts to spin.

If an  $\omega^2t$  run is specified,  $\omega^2t$  starts accumulating.

The rotor accelerates to the set speed. *If you entered a loading speed other than 2000 rpm, re-enter the run speed after you close the door.*

When the run is complete (the run time has expired, the set  $\omega^2t$  value has been reached, or [STOP] has been pressed), the rotor decelerates to the default unloading speed of 2000 rpm. If required, you may enter a different unloading speed of 3000 rpm or below after the rotor reaches 2000 rpm.

**Action**

8. Open the door and unload the rotor.
9. Press [STOP] to bring the rotor to a complete stop.

**Result****WARNING**

**Never try to slow or stop the rotor by hand.**

**NOTE**

Before another zonal run can be started, you must press the RESET soft key.

## SETTING UP AN ELUTRIATION RUN

Centrifuges equipped for elutriation have elutriation controls as shown in Figure 3-1, as well as a view port in the door and an elutriation power box mounted to the back of the control panel. See the JE-6B rotor manual (JE6B-IM) for complete rotor setup and operating instructions.

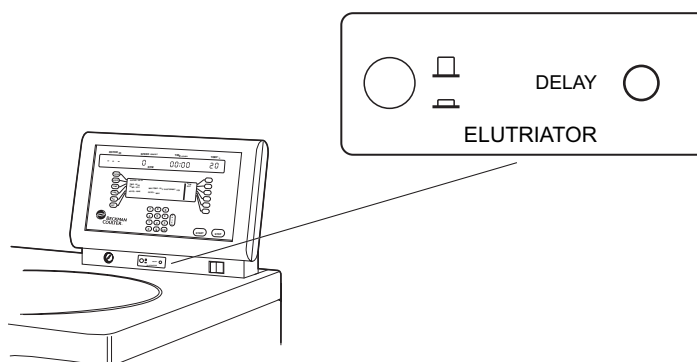

Figure 3-1. Elutriation Controls

**Action**

1. Install the rotor.
2. Set up sample and buffer reservoirs and tubing lines as described in the rotor manual. Route tubing lines through the elutriator port holes at the left side of the door seal.

Close the centrifuge door.

3. Press [**ROTOR**]. Press the JE soft key.

**Result**

JE-6B appears in the **Rotor:** field.

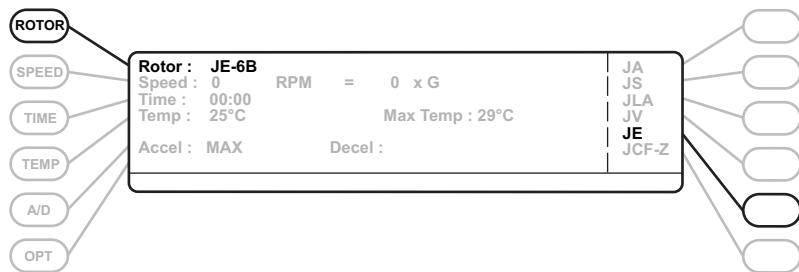

4. Enter the remaining run parameters.
5. Press [**ENTER**], then [**START**].
6. When the rotor reaches set speed, turn on the strobe controls by pressing the strobe control power switch.

The rotor accelerates to set speed.

The power switch indicator lights.

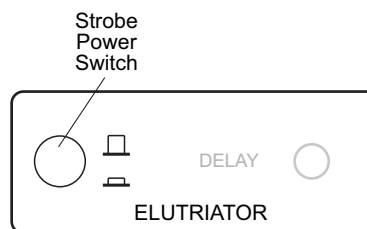

## Action

---

7. When the rotor speed has stabilized, look through the port in the centrifuge door and turn the DELAY knob until the elutriation chamber in the rotor is synchronized with the strobe. (The chamber will appear to be motionless).

## Result

---

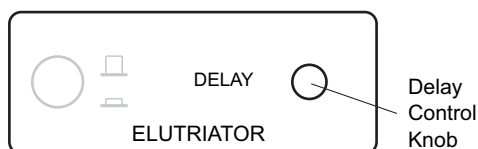

Sample can now be injected into the lines. See the rotor instruction manual for detailed instructions.

## NOTE

---

At the end of the run, after disassembling the liquid and power lines, be sure to replace the black rubber stoppers in the ports at the left side of the centrifuge door. Failure to seal these openings will prevent proper operation of the FRS system, which will cause a diagnostic shut down during the next run.

---



---

# Troubleshooting

*This section lists possible malfunctions, along with probable causes and corrective actions. Maintenance procedures are given in Section 5. For any problems not covered here, contact Beckman Coulter Field Service (1-800-742-2345 in the United States) for assistance.*

## NOTE

It is your responsibility to decontaminate the instrument, as well as any rotors and accessories, before requesting service by Beckman Coulter Field Service.

## USER MESSAGES

User messages appear on the setup screen to communicate information about the instrument or to alert you to abnormal conditions that need attention.

- Help messages caused by incorrect input or certain operating conditions can be cleared by pressing [CE] and following the instructions in the message.
- Diagnostic messages that result from abnormal operating conditions or equipment malfunction require troubleshooting. Refer to Table 4-1 to determine the nature of the condition and any recommended actions. If a problem persists after you have performed the recommended action, call your Beckman Coulter Field Service representative. To help the field service representative diagnose and correct the problem, gather as much information about the situation as you can, including:

- the diagnostic number and message,
- the operating situation when the diagnostic condition occurred (such as rotor in use, speed, or load type), and
- any unusual environmental and/or operating conditions (such as ambient temperature or voltage fluctuations).

**NOTE**

The information provided in Table 4-1 is a user guide, and is not a comprehensive checklist.

Table 4-1. Diagnostic Message Chart

Diagnostic Number/ Message	Problem	Result	Recommended Action
P1/ Power failure, run continued	Momentary power failure: rotor does not come to a complete stop	Run continues when power resumes	Press [CE] to clear message.
P2/ Power failure, run restarted	Power failure: rotor comes to a complete stop	Run will restart automatically when power resumes	Press [CE] to clear message.
L2/ Door not latched, reclose door  L5/ Door not latched, call Beckman service	Door not closed firmly enough, or debris in latch area may be preventing latches from closing securely	L2 error message appears. If you reclose the door repeatedly and the problem continues, the message will change to say "L5 Door not latched, call Beckman Coulter service"	Reclose the door firmly, placing your hand over the drawing of the hand on the door label. (As you close the door your hand should be half-way between the two latches, which is approximately 45° to the right of center front.)  Gently clean the latch areas with a dry, lintless cloth. Be careful not to damage sensitive electronics in the area. If L2 continues to appear after cleaning, call Beckman Coulter Field Service.*
L3/ Door problem, refer to manual  L9/ Door problem, refer to manual	Foot pedal was depressed before end of run	Latches are not operating properly	Press [CE] and try to restart the run. If this does not work, call Beckman Coulter Field Service.

\* In the U.S. call 1-800-742-2345. Outside the United States, contact your local Beckman Coulter office.

Continued —

Table 4-1. Diagnostic Message Chart (continued)

Diagnostic Number/ Message	Problem	Result	Recommended Action
L4/ Door problem, refer to manual	Door stays locked after rotor stops spinning	Sample cannot be retrieved	Restart the centrifuge and perform a brief run. If door will still not open after decel, call Beckman Coulter Field Service.*
C2/ Rotor over temp, run stopped	Rotor temperature exceeds maximum temperature setting	Run shuts down with maximum brake	Call Beckman Coulter Field Service.
C3/ No temp control, refer to manual	Refrigeration system malfunction	Run shuts down with maximum brake	<ul style="list-style-type: none"> <li>• Check the air filter and replace if dirty (see Section 5, Care and Maintenance).</li> <li>• Call Beckman Coulter Field Service.</li> </ul>
D1-5/ Drive error, call Beckman Field Service	Drive system problem (for example, over current, over/under voltage, components over temperature)	Run stops, usually with no brake. Door may not unlock for up to an hour.	Call Beckman Coulter Field Service. Before trying to open the door, listen carefully and make sure that no sound is coming from the chamber (indicating a spinning rotor). Follow the directions under ACCESSING THE ROTOR IN CASE OF POWER FAILURE, below.
F1, F4, F5/ FRS† failure, refer to manual	Required FRS level not reached	Run shuts down with maximum brake	<ul style="list-style-type: none"> <li>• Check and clean door sealing area and door gasket.</li> <li>• Wipe excess moisture from chamber.</li> <li>• Make sure that elutriator port stoppers are in place at left side of door seal.</li> </ul>
F2/ FRS failure, refer to manual	FRS level too high	Run continues	Press [CE]. If F2 message reappears, perform same actions as for F1 error.
F3/ FRS failure, refer to manual	FRS level too high	Run shuts down with maximum brake	Call Beckman Coulter Field Service.
S1/ System error	There is a problem with the system control software, EPROM, or RAM	System shuts down	Call Beckman Coulter Field Service.

\* In the U.S. call 1-800-742-2345. Outside the United States, contact your local Beckman Coulter office.

† Friction Reduction System.

Continued —

Table 4-1. Diagnostic Message Chart (continued)

Diagnostic Number/ Message	Problem	Result	Recommended Action
H4/ Speed error	<p>a) a run is in progress (at speed or accelerating)</p> <p>b) the operator changes the speed to 0 rpm by pressing [SPEED], 0, [ENTER] rather than by pressing the [STOP] key</p> <p>c) the operator then tries to increase the speed by pressing [SPEED], entering a new speed, and pressing [ENTER].</p>	<p>The centrifuge does not accelerate, and the H4 diagnostic occurs.</p> <p>(Note that during a run, the speed can be changed from any speed other than 0 by pressing [SPEED], entering the new speed, and pressing [ENTER].)</p>	<p>Press [STOP] (green light on [START] key will turn off), then press [CE] to clear the diagnostic. Set the new run speed and then press [ENTER], [START] to begin a new run.</p>
I1/ Imbalance error	Rotor load is severely out of balance	Run shuts down with maximum brake	<ul style="list-style-type: none"> <li>• Make sure that tubes or bottles are loaded symmetrically in the rotor.</li> <li>• With swinging bucket rotors, lubricate the buckets according to the rotor manual instructions. Unlubricated pivot pins can prevent the buckets from reaching horizontal position, which can cause imbalance.</li> </ul>
—	During low-temperature runs (near $-10^{\circ}\text{C}$ ), ice forms around the door opening	Door will not open at the end of a run	<p>Press firmly in several locations around the door opening, then depress the foot pedal again.</p> <p>To minimize icing, wipe moisture from the chamber, the chamber gasket and the inner door surface before each run. Keep the door closed as much as possible.</p>



## ACCESSING THE ROTOR IN CASE OF POWER FAILURE



### **WARNING**

---

**Any maintenance procedure requiring removal of a panel exposes the operator to the possibility of electrical shock and/or mechanical injury. Therefore, turn the power off (O) and disconnect the instrument from the main power source, and refer such maintenance to qualified service personnel.**

---



### **WARNING**

---

**Before performing this procedure, verify that the rotor is not spinning by listening carefully for any noise coming from the chamber. Proceed only if the instrument is quiet. Never attempt to override the door interlock system while the rotor is spinning.**

---

If the facility power fails momentarily, the centrifuge will resume operation when the power is restored and the rotor will return to the set speed. In the event of an extended power failure, you may need to override the door-locking mechanism manually to remove the rotor and retrieve your sample.

To access the door-locking mechanism, you must remove the instrument front panel. Two latches secure the front panel in place; these latches are accessible through two holes at the upper right and left of the panel (see Figure 4-1).

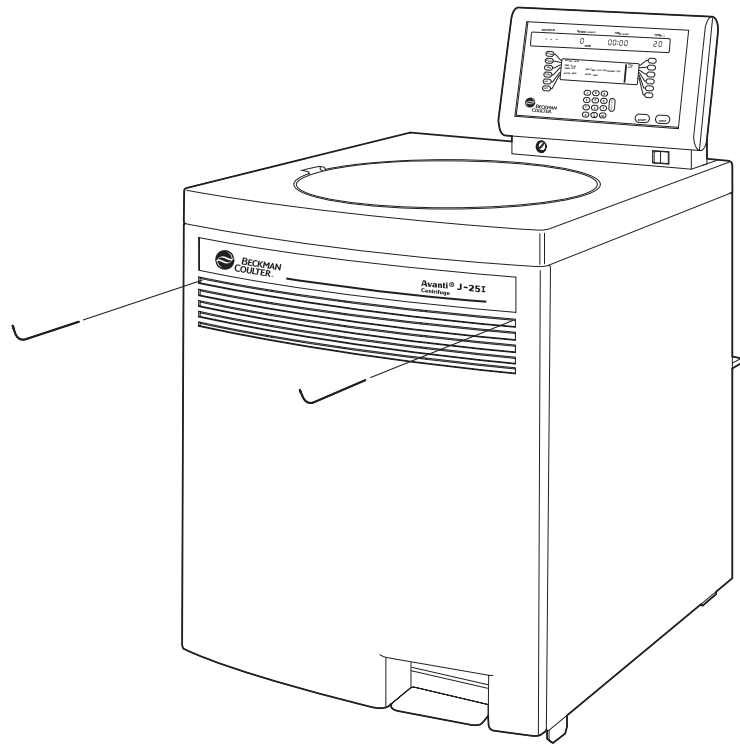

Figure 4-1. Emergency Door Release Latch Access

### Action

---

1. Turn the power switch to off (O) and unplug the power cord from the main source.
2. Insert a 4-mm or  $5/32$ -in. Allen wrench straight through one of the holes (either one) and turn the wrench to the left (counter-clockwise) about one-half turn.
3. Repeat step 2, inserting the wrench through the other hole.

### Result

---

The latch disengages.

After the second latch disengages, the front panel will fall forward about an inch from the top. The bottom of the front panel is held in place by three grooved brackets, attached to the front panel, that seat over a metal retaining strip on the centrifuge bottom panel.

**Action**

4. Lift the front panel up and off the centrifuge; set it aside.

**Result**

An inner front panel extends about halfway down from the centrifuge top (see Figure 4-2). Below this inner panel is a black manual door release interlock switch (see Figure 4-2).

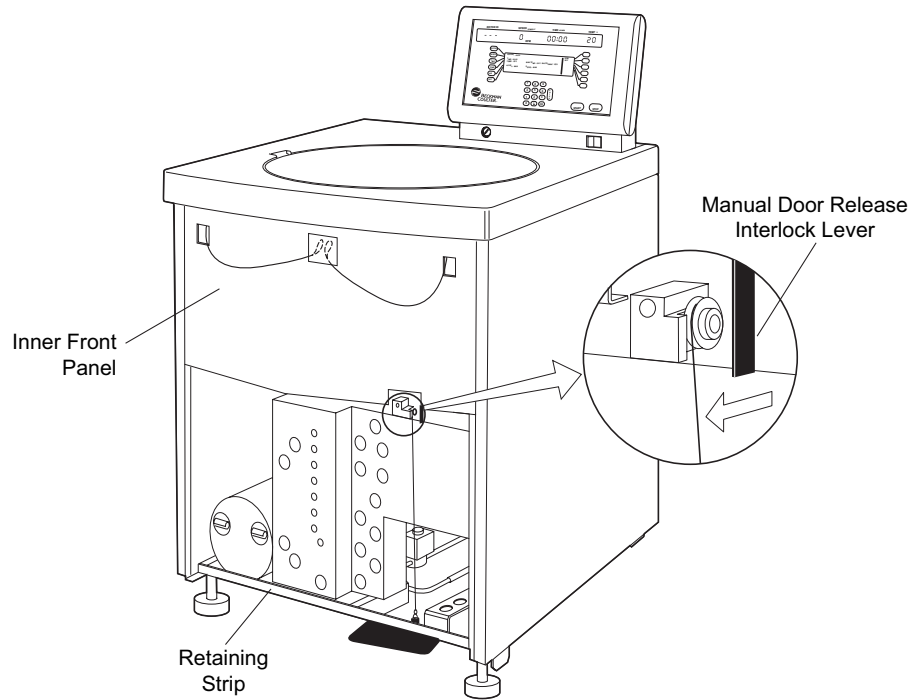

Figure 4-2. Manual Door Release

5. Pull the interlock lever out and to the left (at about a 45-degree angle), and while holding it out, step on the foot pedal.
6. After the door opens, first release the foot pedal and then release the interlock lever.

Depending on the level of vacuum in the chamber at the time of the power failure, the door may or may not open. If it opens, go to step 6. If it doesn't open, you will need to manually vent the vacuum. Go to step 7.

Sample can be removed. Go to step 10.

**Action**

---

7. To vent the chamber vacuum, grasp the red rubber hose and pull it up until it comes off of the pump fitting (see Figure 4-3). Use a back-and-forth motion as you pull; this takes quite a bit of force.

**Result**

---

The vacuum will be completely vented several seconds after the hose is detached.

 **NOTE**

---

Several tubing lines are tied to the red hose. As you grasp the hose, place your hand over these lines. Make sure that they stay connected as you pull.

---



**CAUTION**

---

*Do not twist the hose to the left (counterclockwise) as you pull the hose, or you will unscrew the hose fitting.*

---

8. Replace the hose by pushing it down over the fitting as far as it can go.
9. Pull the interlock lever out and to the left, and while holding it out, step on the foot pedal.



**WARNING**

---

**Never try to slow or stop the rotor by hand.**

---

10. Remove your sample.

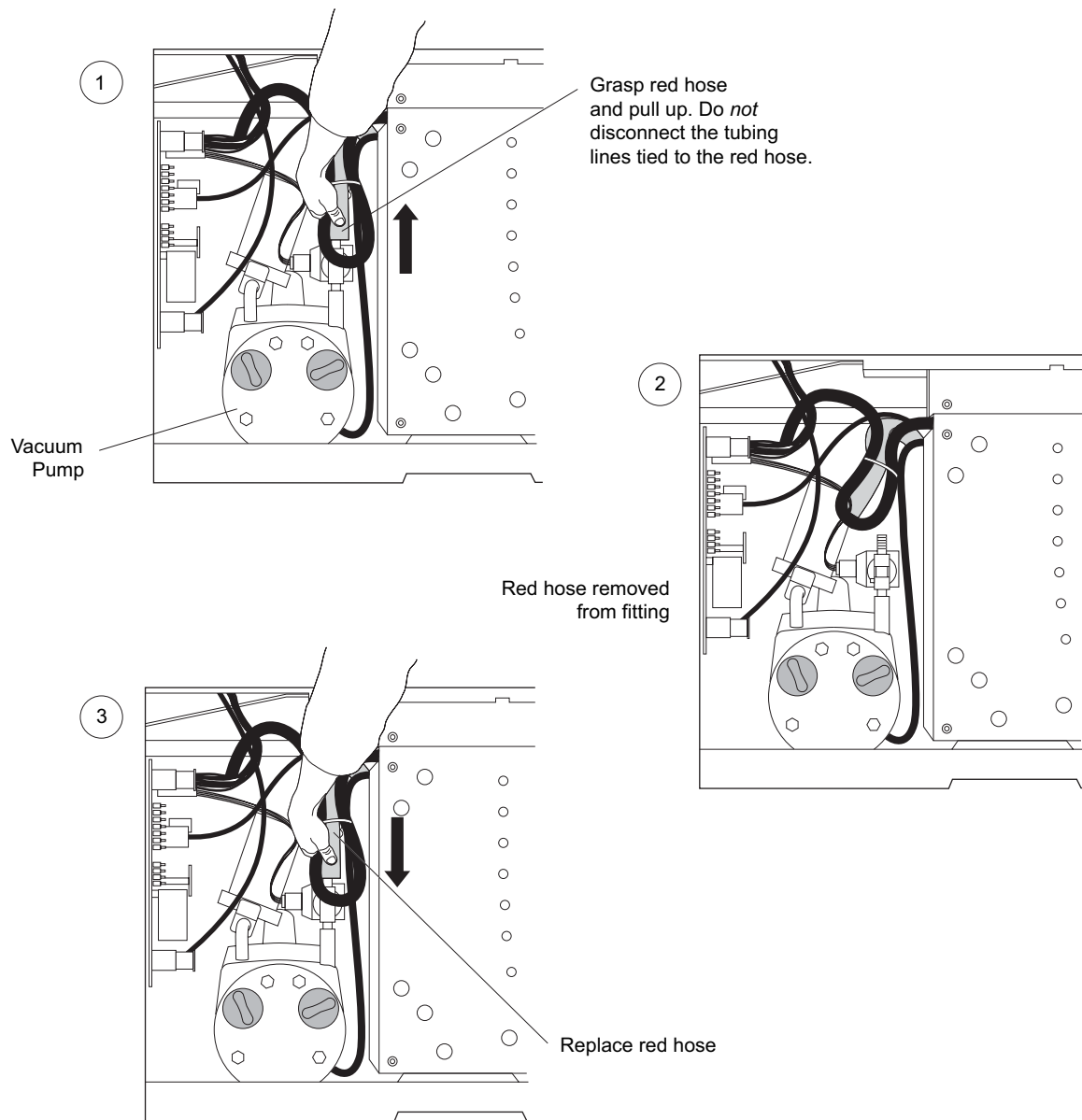

Figure 4-3. Venting the Chamber Vacuum

To replace the panel on the centrifuge,

**Action**

1. Holding the panel at the top (with the instrument label facing out), insert the three grooved brackets on the bottom inside of the door over the front panel retaining strip (see Figure 4-4). Push the top of the front panel into place.

**Result**

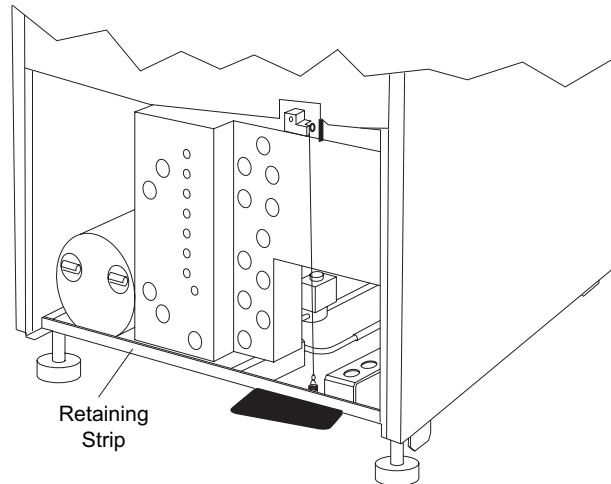

Figure 4-4. Front Panel Retaining Strip

2. Hold the left top edge in place and insert the allen wrench through the hole. Turn to the right (clockwise) about one-half turn, until you reach a stop.

The first latch engages.

3. Repeat step 2 on the right side.

The second latch engages.

## JCF-Z ROTOR IDENTIFICATION

The rotor identification system can, under two specific conditions, misidentify the JCF-Z continuous flow/zonal rotor. Misidentification has occurred if a rotor name other than JCF-Z appears in the ROTOR display during the run, when rotor identification is complete. If the rotor is misidentified, stop the run and follow one of the steps below.

**NOTE**

Misidentification can be prevented by returning your JCF-Z rotor to the Beckman Coulter factory to have magnets added to the rotor body. The magnets ensure correct rotor identification in Avanti J series centrifuges. Call Beckman Coulter Field Service<sup>1</sup> for more information.

JCF-Z rotors manufactured after March, 1997, have factory-installed magnets.

- *On the first few uses of a new JCF-Z rotor, or in an older JCF-Z rotor with newly replaced bearings, run the rotor from 0 to 5000 rpm and back to 0 rpm three times. This procedure will distribute lubricant around the bearings in the rotating seal assembly, reducing drag.*
- *In older JCF-Z rotors with bearings that have not been replaced recently, follow the same procedure as for a new JCF-Z rotor (perform three runs from 0 to 5000 rpm and back to 0 rpm) to ensure that the bearings are properly lubricated. If misidentification recurs after the third run, when the bearings are lubricated, this indicates that the bearings are worn and need to be replaced. Replace the bearings following the instructions in the JCF-Z manual (JCFZ-IM).*

**NOTE**

If the JCF-Z rotor is misidentified, the run speed will be limited to the maximum speed for the identified rotor. (The maximum speed for the JCF-Z rotor is 20 000 rpm.)

<sup>1</sup> In the U.S. call 1-800-742-2345. Outside the United States, contact your local Beckman Coulter office.

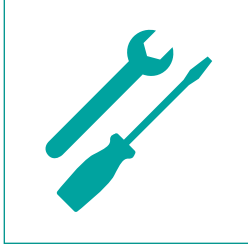

---

# Care and Maintenance

*This section describes routine care and maintenance procedures that you should perform regularly or as required. For maintenance not covered in this manual, contact Beckman Coulter Field Service.<sup>1</sup> Refer to the applicable rotor manual and Rotors and Tubes for J Series Centrifuges (publication JR-IM) for instructions on the care of rotors and accessories.*

## NOTE

It is your responsibility to decontaminate the instrument, as well as any rotors and accessories, before requesting service by a Beckman Coulter Field Service representative.

---



## WARNING

**Any maintenance procedure or servicing of this equipment that requires removal of any covers can expose parts which involve the risk of electric shock or personal injury. Make sure that the power switch is off (O) and the centrifuge is disconnected from the main power source, and refer such servicing to qualified service personnel.**

---



## WARNING

**Do not use alcohol or other flammable substances in or near operating centrifuges.**

---

---

<sup>1</sup> In the U.S., call 1-800-742-2345. Outside the U.S., contact your local Beckman Coulter office.



## MAINTENANCE

Perform the following procedures regularly to ensure continued performance and long service life of the centrifuge.

- Inspect the interior of the centrifuge chamber for accumulations of sample, dust, or glass particles from broken sample tubes. Clean as required (see CLEANING, below).
- Check the air filter on the back panel for obstructions. Keep vents clear and clean.
- Wipe condensation out of the rotor chamber between runs with a sponge or clean cloth to prevent chamber icing.
- If chamber icing occurs, defrost the system and wipe moisture out of the chamber before use. To defrost the system, set the temperature to 30°C for 20 minutes. (These are suggested settings which may be adjusted as appropriate for your laboratory conditions.)

## CLEANING

---

Clean the centrifuge frequently. Always clean up spills when they occur to prevent corrosives or contaminants from drying on component surfaces.

- To prevent accumulations of sample, dust, and/or glass particles from broken sample tubes, keep the chamber clean and dry by frequent wiping with a cloth or paper towel. For thorough cleaning, wash the chamber using a mild detergent such as Beckman Solution 555™, diluted 10 to 1 with water. Rinse thoroughly and dry completely.
- Clean the centrifuge exterior surfaces by wiping with a cloth dampened with Solution 555, diluted 10 to 1 with water. Do not use acetone.
- Clean the drive hub regularly using Solution 555 (diluted 10 to 1 with water) and a soft brush. Rinse thoroughly and dry completely.

## Tube Breakage

---

If a glass tube breaks, and all the glass is not contained in the bucket or rotor, be sure to thoroughly clean the chamber.



### **WARNING**

---

**Be careful when examining or cleaning the chamber and chamber gasket, as sharp glass fragments may be embedded in their surfaces.**

---

- Examine the chamber gasket to make sure that no glass particles are retained in it. Carefully remove any glass particles that may remain.
- Carefully wipe away any glass particles that remain in the chamber.

## DECONTAMINATION

---



If the instrument and/or accessories are contaminated with radioactive or pathogenic solutions, perform appropriate decontamination procedures. Refer to Appendix A in *Rotors and Tubes* or publication IN-175 to be sure the decontamination method will not damage any part of the centrifuge.

## STERILIZATION AND DISINFECTION

---

The centrifuge is finished with urethane paint. Ethanol (70%)<sup>2</sup> may be used on this surface. See Appendix A in *Rotors and Tubes* or publication IN-175 for chemical resistances of centrifuge and accessory materials.

While Beckman Coulter has tested these methods and found that they do not damage the centrifuge, no guarantee of sterility or disinfection is expressed or implied. When sterilization or disinfection is a concern, consult your laboratory safety officer regarding proper methods to use.

---

<sup>2</sup> Flammability hazard. Do not use in or near operating centrifuges.

## REPLACING THE AIR FILTER

---

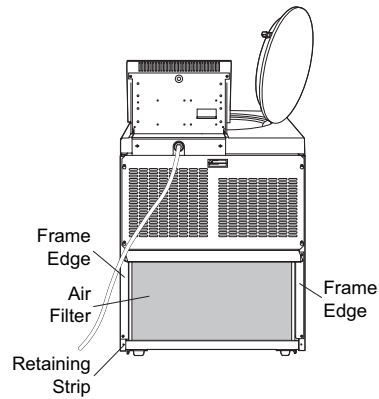

Check the air filter regularly and replace it about once a year, or more often if it looks dirty. The air filter is not fastened to the centrifuge, so no tools are required for removal or installation.

1. To remove the air filter, hold the side edges and lift the filter straight up until the bottom edge is above the centrifuge bottom retaining strip. Pull the filter out, bottom edge first, and discard it.
2. Install a new filter (885218). The filter has a directional arrow on one of its edges; install the filter with this arrow pointing toward the centrifuge. Holding the filter by the side edges, insert the top half behind the frame edge and lift up until the bottom half clears the retaining strip. Then set the bottom edge down.

## CIRCUIT BREAKER AND FUSES

---

There are no user-replaceable fuses in the Avanti J-25I centrifuge.



If the circuit breaker trips for any reason, the power switch will move to the OFF (O) position. Reset the circuit breaker by turning the power switch back to the ON (I) position. If it trips again immediately, *do not reset it*. Call Beckman Coulter Field Service.



### CAUTION

*Repeated attempts to reset the circuit breaker can cause substantial damage to electrical and electronic components.*

---

## STORAGE AND TRANSPORT

### STORAGE

---

To ensure that the centrifuge does not get damaged, contact Beckman Coulter Field Service for specific instructions and/or assistance in preparing the equipment for transport or long-term storage. Temperature and humidity conditions for storage should meet the environmental requirements described under SPECIFICATIONS.

### RETURNING A CENTRIFUGE

Before returning a centrifuge or accessory for any reason, prior permission (a Returned Goods authorization form) must be obtained from Beckman Coulter, Inc. Contact your local Beckman Coulter office to obtain the RGA form and for packaging and shipping instructions.

To protect our personnel, it is the customer's responsibility to ensure that all parts are free from pathogens and/or radioactivity. Sterilization and decontamination must be done before returning the parts.

*All parts must be accompanied by a note, plainly visible on the outside of the box or bag, stating that they are safe to handle and that they are not contaminated with pathogens or radioactivity. **Failure to attach this notification will result in return or disposal of the items without review of the reported problem.***

## SUPPLY LIST

Refer to *Beckman Coulter High Performance, High Speed, High Capacity Rotors, Tubes & Accessories* (BR-8102, available at [www.beckmancoulter.com](http://www.beckmancoulter.com)) and the applicable rotor manual for materials and supplies needed for rotors.

### REPLACEMENT PARTS AND SUPPLIES

---

Air filter. . . . .	885218
Beckman Solution 555™ (1 qt) . . . . .	339555
Zonal Bracket Kit for Cole-Parmer size 16 tubing	
(6.4-mm [ <sup>1</sup> / <sub>4</sub> -in.] O.D.) . . . . .	363843
Zonal Bracket (qty 1) . . . . .	363818
Thumbscrew, stainless steel, M4 (threads) × 19 mm (qty 2) . . . . .	893412
Thumbscrew, stainless steel, M4 (threads) × 12 mm (qty 2) . . . . .	893411
Cable Clamp, nylon, 6.4-mm ( <sup>1</sup> / <sub>4</sub> -in.) I.D. (qty 10) . . . . .	000499
Zonal Tubing Adapter for Cole-Parmer size 14 tubing	
(4.8-mm [ <sup>3</sup> / <sub>16</sub> -in.] O.D.) . . . . .	363844
<b>Note:</b> kit 363843 is also required.	
Tubing Adapter, stainless steel, for size 14 tubing (qty 2) . . . . .	363830
Cable Clamp, nylon, 4.8-mm ( <sup>3</sup> / <sub>16</sub> -in.) I.D. (qty 10). . . . .	003343
Zonal Tubing Adapter for Cole-Parmer size 15 tubing	
(9.6-mm [ <sup>3</sup> / <sub>8</sub> -in.] O.D.) . . . . .	363845
<b>Note:</b> kit 363843 is also required.	
Tubing Adapter, stainless steel, for size 15 tubing (qty 2) . . . . .	363831
Cable Clamp, nylon, 9.6-mm ( <sup>3</sup> / <sub>8</sub> -in.) I.D. (qty 10) . . . . .	000596
Elutriation upgrade kit. . . . .	363841

---

# Temperature Calibration Procedure

The Avanti J-25I centrifuge specification for temperature control is  $\pm 2^{\circ}\text{C}$  of the set temperature. That means that your sample will stay within  $2^{\circ}\text{C}$  of set temperature at all times, after rotor and system equilibration, described below. (During transient conditions, such as acceleration and deceleration, the rotor temperature may be outside this range.) The following procedure is provided for those cases in which temperature control within  $\pm 1^{\circ}\text{C}$  is required.

In this procedure, you will measure the temperature of your sample after equilibrating the rotor temperature for a minimum of 1 hour. Based on the test results, you can then adjust the centrifuge temperature setting to bring your sample as close as possible to the required temperature.

1. Precool the rotor in a refrigerator to the required temperature. The length of precooling time depends on how different the rotor starting temperature is from the required run temperature.
2. Install the precooled rotor with adapters, if applicable, and tubes or bottles filled with sample buffer or water (if above  $2^{\circ}\text{C}$ ).
3. Set the speed to 2000 rpm, the time to HOLD, and the temperature to the required run temperature. Start the run.
4. After 30 minutes, set the required run speed, and allow the system to run for at least 1 hour.

## NOTE

---

*The system must run for at least 1 hour before the temperature of the buffer or water is measured. The length of time required for the system to reach equilibration depends on the rotor and centrifuge starting temperatures and the ambient room temperature.*

---

5. After at least 1 hour, measure the temperature of the buffer or water using a thermometer or thermocouple.
6. If the measured and set temperatures are different, note how many degrees different the measurements are and adjust the set temperature up or down that number of degrees.

For example:

If the required sample temperature is	And the measured buffer/water temperature is	Set the temperature to
4°C	6°C	2°C
5°C	4°C	6°C

---

## **AVANTI® J SERIES CENTRIFUGE WARRANTY**

Subject to the exceptions and upon the conditions specified below Beckman Coulter agrees to correct either by repair, or, at its election, by replacement, any defects of material or workmanship which develop within one (1) year (3 years for the drive motor) after delivery of the Avanti® J Series Centrifuge centrifuge (the product), to the original buyer by Beckman Coulter or by an authorized representative, provided that investigation and factory inspection by Beckman Coulter discloses that such defect developed under normal and proper use.

Some components and accessories by their nature are not intended to and will not function for as long as one (1) year. If any such component or accessory fails to give reasonable service for a reasonable period of time, Beckman Coulter will repair or, at its election, replace such component or accessory. What constitutes either reasonable service and a reasonable period of time shall be determined solely by Beckman Coulter.

### **REPLACEMENT**

Any product claimed to be defective must, if requested by Beckman Coulter, be returned to the factory, transportation charges prepaid, and will be returned to Buyer with the transportation charges collect unless the product is found to be defective, in which case Beckman Coulter will pay all transportation charges.

Beckman Coulter makes no warranty concerning products or accessories not manufactured by it. In the event of failure of any such product or accessory, Beckman Coulter will give reasonable assistance to the Buyer in obtaining from the respective manufacturer whatever adjustment is reasonable in light of the manufacturer's own warranty.

### **CONDITIONS**

Beckman Coulter shall be released from all obligations under all warranties, either expressed or implied, if the product covered hereby is repaired or modified by persons other than its own authorized service personnel, unless such repair by others is made with the written consent of Beckman Coulter, or unless such repair in the sole opinion of Beckman Coulter is minor, or unless such modifications is merely the installation of a new Beckman Coulter plug-in component for such product.

### **DISCLAIMER**

IT IS EXPRESSLY AGREED THAT THE ABOVE WARRANTY SHALL BE IN LIEU OF ALL WARRANTIES OF FITNESS AND OF THE WARRANTY OF MERCHANTABILITY AND THAT BECKMAN COULTER, INC. SHALL HAVE NO LIABILITY FOR SPECIAL OR CONSEQUENTIAL DAMAGES OF ANY KIND WHATSOEVER ARISING OUT OF THE MANUFACTURE, USE, SALE, HANDLING, REPAIR, MAINTENANCE, OR REPLACEMENT OF THE PRODUCT.



# Beckman Coulter Worldwide Biomedical Research Division Offices

## AUSTRALIA

Beckman Coulter Australia Pty Ltd  
Unit D, 24 College St.  
Gladesville, NSW 2111  
Australia  
**Telephone: (61) 2 9844-6000**  
**or toll free: 1 800 060 880**  
**Fax: (61) 2 9844-6096**  
**email: lifescienceaustralia@beckman.com**

## CANADA

Beckman Coulter (Canada) Inc.  
6755 Mississauga Road, Suite 600  
Mississauga, Ontario  
Canada L5N 7Y2  
**Telephone: (905) 819-1234**  
**Fax: (905) 819-1485**

## CHINA

Beckman Coulter Inc.  
Beijing Representative Office  
Unit 2005A, 2006-2009, East Ocean Center  
Jian Guomenwai Avenue  
Beijing 100004  
China  
**Telephone: (86) 10 6515 6028**  
**Fax: (86) 10 6515 6025, 6515 6026**

## EASTERN EUROPE/ MIDDLE EAST/NORTH AFRICA

Beckman Coulter International S.A.  
22, Rue Juste-Olivier  
Case Postale 301-303  
CH-1260 Nyon, Switzerland  
**Telephone: (41) 22 994 07 07**  
**Fax: (41) 22 994 07 00**

## FRANCE

Beckman Coulter France S.A.  
Paris Nord II, 33/66 rue des Vanesses  
B.P. 50359  
Villepinte, France  
95942 ROISSY CDG Cedex  
**Telephone: 01 49 90 90 00**  
**Fax: 01 49 90 90 10**  
**e-mail: bioresearch.france@beckman.com**

## GERMANY

Beckman Coulter GmbH  
Europark Fichtenhain B-13  
47807 Krefeld  
Germany  
**Telephone: 49 21 513335**  
**Fax: 49 21 51333633**  
**e-mail: bioresearch.de@beckman.com**

## HONG KONG

Beckman Coulter Hong Kong Ltd.  
12th Floor, Oxford House  
979 King's Road  
Taikoo Place, Hong Kong  
**Telephone: (852) 2814 7431, 2814 0481**  
**Fax: (852) 2873 4511**

## ITALY

Beckman Coulter S.p.a.  
Centro Direzionale Lombardo  
Palazzo F/1, Via Roma 108  
20060 Cassina de' Pecchi  
Milano, Italy  
**Telephone: 02-953921**  
**Fax: 02-95392264**

## JAPAN

Beckman Coulter K.K.  
TOC Ariake West Tower  
2-5-7, Ariake, Koto-ku  
Tokyo 135-0063 Japan  
**Telephone: 03-5404-8359**  
**Fax: 03-5404-8436**

## MEXICO

Beckman Coulter de Mexico S.A. DE C.V.  
Avenida Popocatepetl #396  
Colonia Gral. Pedro Maria Anaya  
Codigo Postal 03340  
Mexico, D.F. Mexico  
**Telephone: 52-55-9183-2800**

## NETHERLANDS

Beckman Coulter Nederland B.V.  
Nijverheidsweg 21  
3641 RP-Mijdrecht  
Postbus 47  
3640 AA Mijdrecht  
The Netherlands  
**Telephone: 0297-230630**  
**Fax: 0297-288082**

## SINGAPORE

Beckman Coulter Singapore Pte. Ltd.  
116 Changi Road  
Unit #03-01/02  
Singapore 419718  
**Telephone: (65) 6339 3633**  
**Fax: (65) 6336 6303**

## SOUTH AFRICA/SUB-SAHARAN AFRICA

Beckman Coulter  
Stand 1A Primegro Park  
Tonetti Street  
1685 Halfway House  
Johannesburg  
Republic of South Africa  
**Telephone: (27) 11-805-2014/5**  
**Fax: (27) 11-805-4120**  
**e-mail: beckman@intekom.co.za**

## SPAIN

Beckman Coulter España S.A.  
C/ Caleruega, 81  
28033 Madrid, Spain  
**Telephone: 91 3836080**  
**Fax: 91 3836096**  
**email: bioresearch.espana@beckman.com**

## SWEDEN

Beckman Coulter AB  
Archimedesvaegen 7  
Box 111 56  
SE-168 11 Bromma  
Sweden  
**Telephone: (0)8 564 85 900**  
**Telefax: (0)8 564 85 901**

## SWITZERLAND

Beckman Coulter International S.A.  
22, Rue Juste-Olivier  
Case Postale 301-303  
CH-1260 Nyon  
Switzerland  
**Telephone: 0800 850 810**  
**Fax: 0848 850 810**

## TAIWAN

Beckman Coulter Taiwan Inc.  
Taiwan Branch  
8th Floor  
216 Tun Hwa South Road, Section 2  
Taipei 106, Taiwan  
Republic of China  
**Telephone: (886) 2 2378 3456**  
**Fax: (886) 2 2377 0408**

## TURKEY

Beckman Coulter Ltd.  
E-5 Yanyol Faith Cad.  
81410 Sogankik Kartal  
Istanbul  
Turkey  
**Telephone: 90 216 309 1900**  
**Fax: 90 216 309 0090**

## UNITED KINGDOM

Beckman Coulter United Kingdom Ltd  
Oakley Court  
Kingsmead Business Park  
London Road  
High Wycombe  
Buckinghamshire HP11 1JU  
England, U.K.  
**Telephone: 01494 441181**  
**Fax: 01494 447558**  
**e-mail: beckman\_uk@beckman.com**

*Authorized dealers in other countries.*



Beckman Coulter, Inc. • 4300 N. Harbor Boulevard, Box 3100 • Fullerton, California 92834-3100  
Sales and Service: 1-800-742-2345 • Internet: [www.beckmancoulter.com](http://www.beckmancoulter.com) • Telex: 678413 • Fax: 1-800-643-4366

