



Operating Instructions

VWR Water Jacketed CO₂ Incubator



VWR Catalogue Number	Manufacturer Model Number	Sensor*	Capacity (cu ft)	Voltage
10810-744	VWR51014995	T/C	6.5	115V/60Hz
10810-878	VWR51014996	IR	6.5	115V/60Hz
10810-884	VWR51014900	T/C	6.5 x 2**	115V/60Hz
10810-886	VWR51014901	IR	6.5 x 2**	115V/60Hz

*T/C is a thermal conductivity sensor.

IR is an infra-red sensor.

**Dual stack

All units include HEPA filtration

Legal Address of Manufacturer

United States

VWR International, LLC

100 Matsonford Rd

Radnor, PA 19087

800-932-5000

<http://www.vwr.com>

Country of origin: United States

MANUAL NUMBER 751014995

0	40591	1/13/16	Original	ccs
REV	ECR/ECN	DATE	DESCRIPTION	By



Important Read this instruction manual. Failure to read, understand and follow the instructions in this manual may result in damage to the unit, injury to operating personnel, and poor equipment performance. ▲

Caution All internal adjustments and maintenance must be performed by qualified service personnel. ▲

Material in this manual is for information purposes only. The contents and the product it describes are subject to change without notice. VWR International makes no representations or warranties with respect to this manual. In no event shall VWR International be held liable for any damages, direct or incidental, arising out of or related to the use of this manual.

Intended Use:

The VWR Water Jacketed CO₂ Incubators are designed to maintain an optimal environment for the incubation of tissue and cell samples. These models are designed to maintain temperature and Carbon Dioxide levels as set by the operator as well as monitoring chamber relative humidity. CO₂ is controlled using either a thermo conductivity cell, or an infra-red sensor.

The VWR Water Jacketed Incubators are approved for general purpose use only.

Non-intended Use:

The VWR Water Jacketed Incubators are not intended for use where electrical or physical contact with the patient is established.

These incubators are not intended to be operated in potentially explosive environments and are not intended for use with flammable materials.

The VWR Water Jacketed Incubators are not intended for use as a Microbiological Incubator (21 CFR 866.2540) and are also not approved for use in assisted reproductive procedures for the incubation of ova and embryos (21 CFR 884.6120).

© 2016 VWR International. All right reserved.

Printed in U.S.A.

All trademarks mentioned are the exclusive property of the respective manufacturers.



Important operating and/or maintenance instructions. Read the accompanying text carefully.



Potential electrical hazards. Only qualified persons should perform procedures associated with this symbol.



Equipment being maintained or serviced must be turned off and locked off to prevent possible injury.



Hot surface(s) present which may cause burns to unprotected skin, or to materials which may be damaged by elevated temperatures.

- ✓ Always use the proper protective equipment (clothing, gloves, goggles, etc.)
- ✓ Always dissipate extreme cold or heat and wear protective clothing.
- ✓ Always follow good hygiene practices.
- ✓ Each individual is responsible for his or her own safety.

Do You Need Information or Assistance on VWR International Products?

VWR can provide information on pricing and give you quotations. We can take your order and provide delivery information on major equipment items or make arrangements to have your local sales representative contact you. Our products are listed on the internet and we can be contacted through our Internet home page.

Visit VWR's website at vwr.com for:

- Complete technical service contact information
- Access to VWR's Online Catalogue, and information about accessories and related products
- Additional product information and special offers

For information or technical assistance, contact your local VWR representative, or visit vwr.com.

VWR can supply technical information about proper setup, operation or troubleshooting of your equipment. We can fill your needs for replacement parts or provide you with on-site service. We can also provide you with a quotation on our Extended Maintenance Program for your products.

Whatever VWR products you need or use, we will be happy to discuss your applications. If you are experiencing technical problems, working together, we will help you locate the problem and, chances are, correct it yourself...over the telephone without a service call.

When more extensive service is necessary, we will assist you with direct factory trained technicians or a qualified service organization for on-the-spot repair. If your service need is covered by the VWR International warranty, we will arrange for the unit to be repaired at our expense and to your satisfaction.

Table of Contents

Section 1	Installation and Start-Up	1-1
	Control Panel	1-2
	Unit Installation	1-3
	Stacking	1-3
	Control Panel Operation	1-3
	Installing the Access Port Filter	1-6
	Preliminary Cleaning	1-6
	Installing the Shelves	1-7
	Installing the Air Sample Filter	1-7
	Filling the Water Jacket	1-8
	Connecting the Unit to Electrical Power	1-8
	Leveling the Unit	1-8
	Filling the Humidity Pan	1-9
	Connecting the CO ₂ Gas Supply	1-10
	Incubator Start-Up	1-11
	Setting the Overtemp Setpoint	1-12
	Setting the Operating Temperature Setpoint	1-12
	Setting the CO ₂ Setpoint	1-13
Section 2	Calibration	2-1
	Calibrating the Temperature	2-1
	Calibrating T/C CO ₂ System	2-2
	Calibrating IR CO ₂ System	2-3
Section 3	Alarms	3-1
Section 4	Specifications	4-1

Section 1 Installation and Start-Up

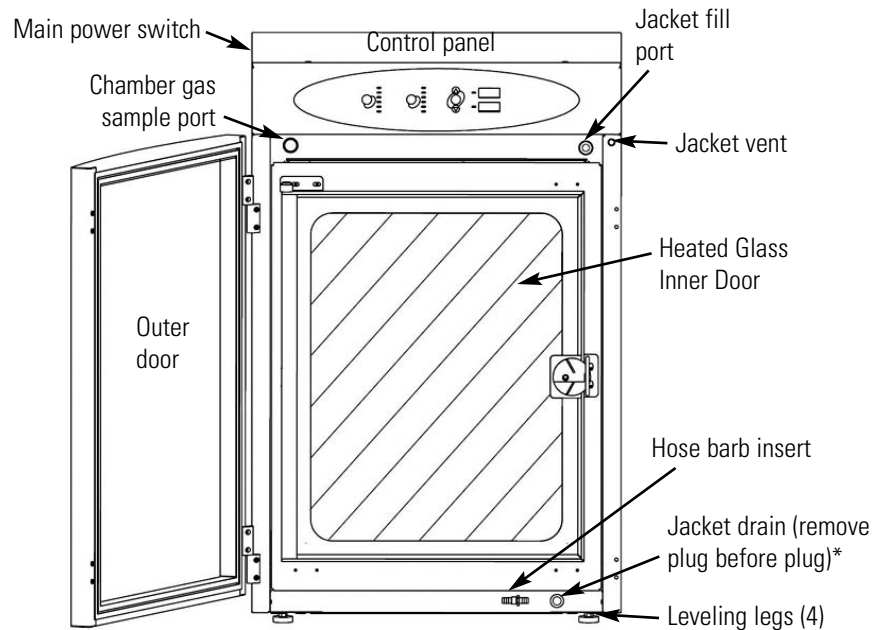

Figure 1-1. Unit Components

- Outer Door - Reversible to opposite swing.
- Heated Inner Door - Keeps chamber interior dry. Reversible to opposite swing.
- Chamber Gas Sample Port - Used for sampling chamber CO₂ content, using a Fyrite or similar instrument.
- Main Power Switch - Cycles unit off and on
- Control Panel - Keypad, Displays and Indicators (Figure 1-2).
- Jacket Fill Port - Used for filling the water jacket.
- Jacket Vent- Do not cover! Allows air to escape from the water jacket during filling and normal expansion and contraction when the incubator heats or cools.
- Leveling Legs - Used to level the unit.
- Jacket Drain – Remove plug and use included hose barb insert, to drain water from water jacket. Plug when not in use.

Note The incubators are stackable. Information follows later in this section. ▲

**When setting up the incubator, install the cover plate packed inside the incubator shipping carton.*

Control Panel

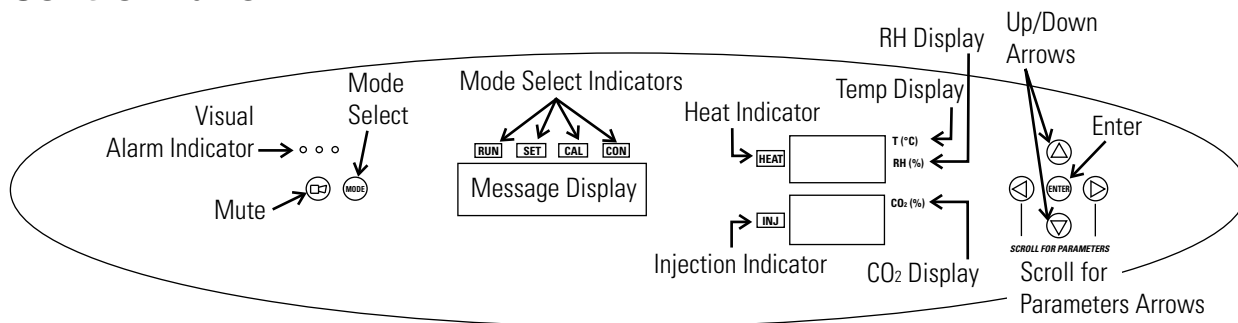

Figure 1-2. Control Panel

Mute - Silences the audible alarm.

Visual Alarm Indicators - Indicator flashes during an alarm condition.

Over Temp - Chamber temp above setpoint

Low Temp - Chamber temp below setpoint

High CO₂ - CO₂ level above setpoint

Low CO₂ - CO₂ level below setpoint

Add Water - Water level in jacket is low

Door Open - Door ajar

Mode Select Indicators - Used to select desired mode.

Mode Select - Selected mode indicator lights.

Run: Normal Operation

Set Temp: Set Temperature Setpoint

Set Otemp: Set Overtemperature Setpoint

Set CO₂: Set CO₂ Control Setpoint

Cal Temp: Calibrate Displayed Temperature (Offset)

Cal CO₂: Calibrate Displayed CO₂ Value (Offset)

Up and Down Arrows - Increase or decrease parameter value

Enter - Saves the selected value

Heat Indicator - Lights when power is applied to the heaters

Injection Indicator - Lights when gas is being injected into the incubator

Temp Display - Shows chamber temperature, temperature setpoint or overtemperature setpoint

CO₂ Display - Shows percentage of CO₂ in the chamber or CO₂ setpoint

Control Panel Operation

The water jacketed incubator has six modes to allow incubator setup. The modes are as follows:

- Run is the default mode that the incubator will normally be in during operation.
- Set Temp is used to enter system temperature setpoints for incubator operation.
- Set Otemp is used to enter system overtemperature setpoints for incubator operation.
- Set CO₂ is used to enter system CO₂ setpoints for incubator operation.
- Cal Temp is used to calibrate displayed chamber temperature.
- Cal CO₂ is used to calibrate displayed percentage of CO₂ in the chamber.

Unit Installation

1. Locate the unit on a firm, level surface capable of supporting the unit's operational weight of 365 lbs. (166kg).
2. Locate away from doors and windows and heating and air conditioning ducts.
3. Allow enough clearance behind the unit for electrical and gas hook-up.

Stacking

If the units have been in service, disconnect the power cord connector and drain the water jacket of the designated top unit before stacking.

Note Stacking brackets (shown at right) stacking bolts, washers, and bolts for stacking are included with each unit. ▲

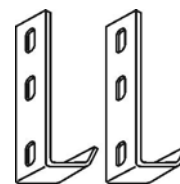

Figure 1-3.
Stacking Brackets

Stacking (continued)

1. Designate one incubator to be the top unit and the other as the bottom unit. Remove the base cover plate from the top unit using the finger holes in the base or using a slotted screwdriver (Figure 1-4).

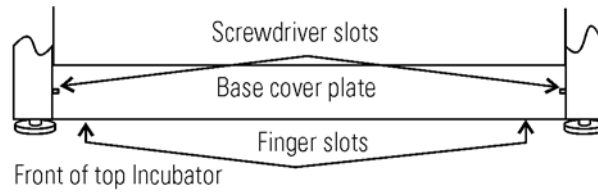
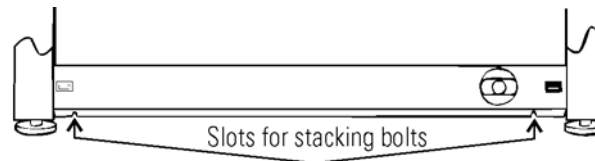

Figure 1-4. Remove Base Cover Plate

2. Note the two slots in the base of the incubator which accommodate the stacking bolts. Refer to Figure 1-5.



Front of top incubator, base cover plate removed

Figure 1-5. Stacking Bolt Slots

3. Remove the two plastic plugs from the bolt holes in the exterior top of the bottom unit. Install the 1/2" long 5/16-18 stacking bolts and washers into the bolt holes - do not tighten the bolts at this time. Refer to Figure 1-6.

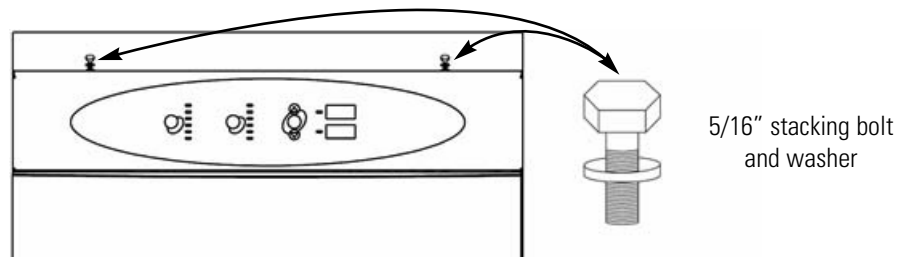

Figure 1-6. Bolt Holes

4. Unscrew and remove the leveling feet from the top unit and lift it onto the bottom unit, off-setting the base of the top unit approximately 2-3 inches behind the stacking bolts and washers.

Caution This incubator weighs 265 lbs (120kg) before filling. Have sufficient personnel to lift it. ▲

Stacking (continued)

5. Align the sides of the top unit with the bottom unit and slide the top unit forward until the slots in the base of the top unit align with the 5/16"-18 stacking bolts in the exterior top of the bottom unit. Refer to Figure 1-7.

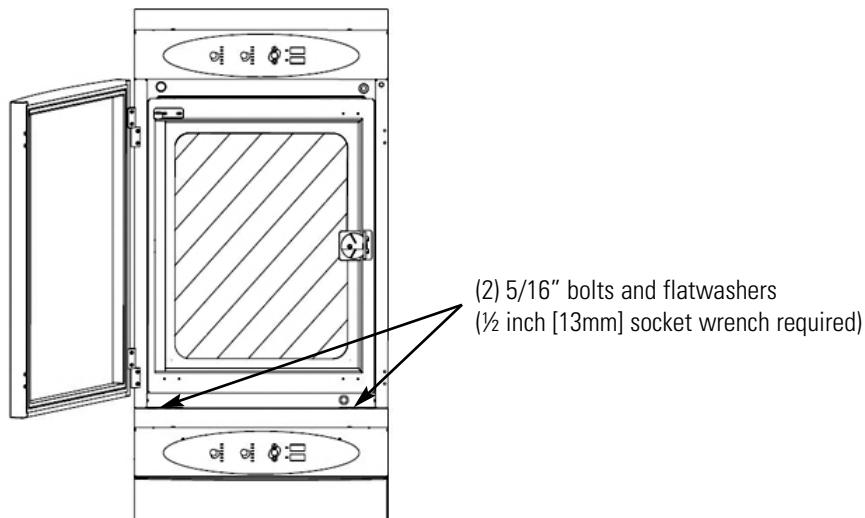

Figure 1-7. Align Slots and Bolts

6. Remove and save the two screws from the back of the control panel on the bottom unit as shown in Figure 1-8.

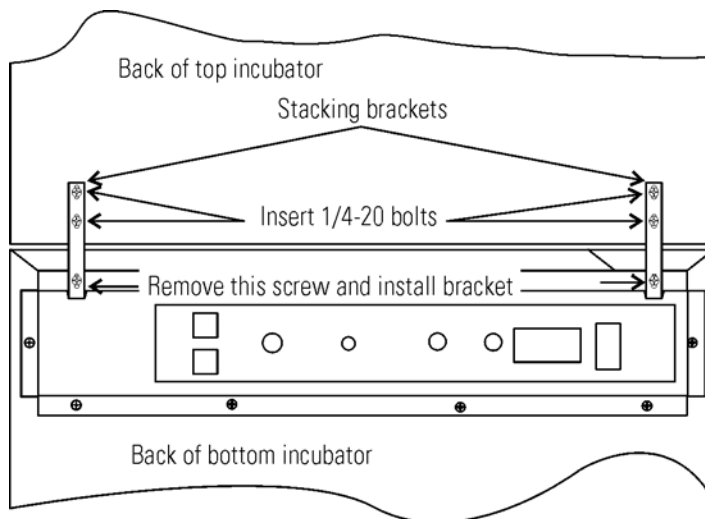

Figure 1-8. Two Screws From Control Panel Back

7. Insert the stacking brackets into the slots on the rear of the control panel of the bottom unit (Figure 1-5). Align the slots in the brackets with the mounting holes on the rear of the incubators. Secure the brackets with the screws saved above and the 1/4-20 bolts provided in the stacking kit. A 7/16" wrench or socket will be required for the bolts.

Stacking (continued)

8. Secure the base of the top unit to the exterior top of the bottom unit by tightening the 5/16-18 stacking bolts using a 1/2" (13mm) wrench or suitable tool.
9. Replace the base cover on the top unit.
10. The stacked units are ready to be placed into service.

Preliminary Cleaning

1. Remove the protective plastic coating on the shelf supports and air duct, if present.
2. Using a suitable laboratory disinfectant, clean all interior surfaces including shelves and shelf supports, door gaskets, blower wheel and CO₂ sensor.

Caution Before using any cleaning or decontamination method except those recommended by the manufacturer, users should check with the manufacturer that the proposed method will not damage the equipment. Accidental spills of hazardous materials on or inside this unit are the responsibility of the user. ▲

Installing the Access Port Filter

Locate the opening in the top left corner of the interior chamber. Remove the tape from the opening on the outside of the unit. Locate the stopper with filter in the hardware bag. Install in the opening inside the chamber. See Figure 1-9.

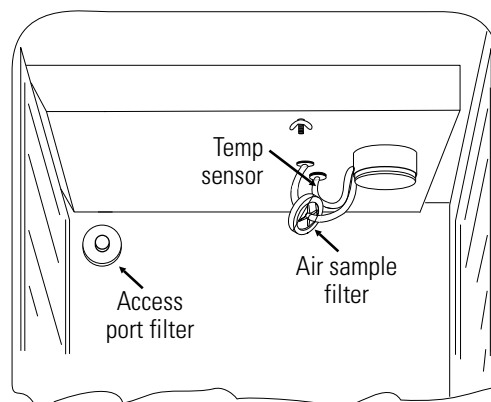

Figure 1-9. Filter and Sensor Locations

Installing the Air Sample Filter

1. Remove the filter from the shipping bag.
2. Separate one section of the tubing from the filter. Install this section to the fitting on the blower plate.
3. After installing the top duct, connect the filter assembly to the tubing coming through the top duct.
4. Insert the free end of the air sample filter tubing into the larger hole in the back of the blower scroll. See Figure 1-9 for completed configuration.

Installing the Shelves

1. Install the side ducts with the tabs facing into the center of the chamber with their slots up. There are no right side or left side ducts, simply rotate one of them to fit the opposite side. Tilt the side ducts as they are placed in the chamber so the tops fit into the top air duct, then guide them into the vertical position. Figure 1-10 shows the duct as it would be oriented for the right side of the chamber.

2. Referring to Figure 1-10, note that there is no difference between left and right side shelf channels.

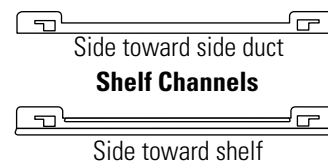

3. Install the shelf channels by placing the channel's rear slot over the appropriate rear tab on the side duct. Pull the shelf channel forward and engage the channel's front slot into the side duct's appropriate forward tab. Refer to Figure 1-11.

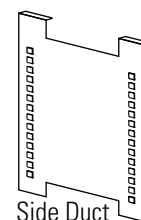

4. Figure 1-12 shows one of the channels installed on the right side duct.

Figure 1-10. Shelf Channels and Side Duct

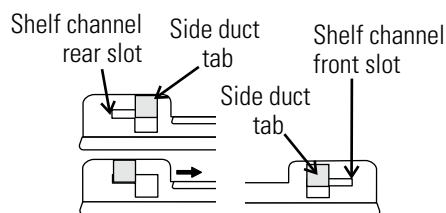

Figure 1-11. Slot and Tab

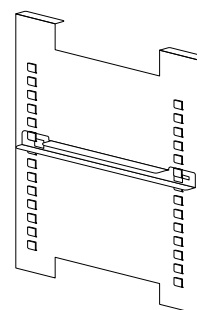

Figure 1-12. Channel Installed

Leveling the Unit

Check the unit for being level by placing a bubble-style level on one of the shelves. Turn the hex nut on the leveler counterclockwise to lengthen the leg, or clockwise to shorten it. Level the unit front-to-back and left-to-right.

Connecting the Unit to Electrical Power

See the serial tag on the side of the unit for electrical specifications, or refer to the electrical schematics included in this manual.

Caution Connect the incubator to a grounded dedicated circuit only. The power cord connector is the mains disconnect device for the incubator. Position the unit so that it can be easily disconnected. ▲

Plug the provided power cord into the power inlet connector (see Figure 1-13) and into the grounded dedicated circuit.

Electrical Specifications: 115V, 50/60Hz, 3.6A, 1 PH, 2W

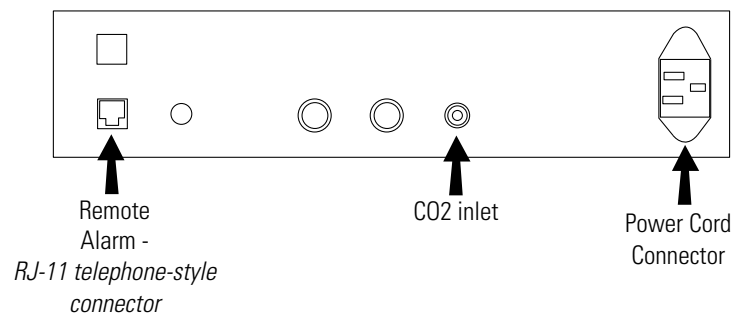

Figure 1-13. Rear Panel - showing all options

Filling the Water Jacket

Turn the power switch on. ADD WATER will appear in the message center. Press the Silence key to silence the alarm.

Note The fill port has a plug that must be removed before filling and replaced after filling is complete. ▲

Caution Chlorine is detrimental to stainless steel. Using chlorinated tap water, or additives that contain chlorine, will void the water-jacket warranty! ▲

Filling the Water Jacket (continued)

Fill the water jacket with 11.7 gallons (43.5 liters) of sterile distilled water. Silicone tubing and a funnel are shipped in the unit accessory bag.

For ease of connecting/disconnecting, use the silicone tubing provided to connect directly to the fill port. See Figure 1-1 and this detail. Do not install vinyl tubing directly onto the fill port as it may be difficult to remove. A 3/8" to 3/8" hose connector has been provided to attach lengths of vinyl tubing to the silicone fill port tubing, to reach the distilled water source.

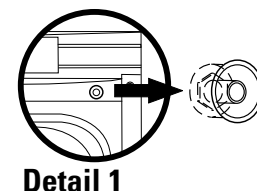

When the jacket is full, the audible alarm sounds a continuous tone for 10 seconds and the alarm condition clears. Refer to Section 3, Table of Alarms.

Note The water jacket incubator is shipped from the factory with a rust inhibitor added to the water inside the unit. The rust inhibitor must be replenished every 2 years. ▲

Filling the Humidity Pan

For best operation of the incubator, sterilized distilled, demineralized or de-ionized water should be used in the humidity pan. Water purity should be in the resistance range of 50K to 1M Ohm/cm, or a conductivity range of 20.0 to 1.0 uS/cm. Refer to ASTM Standard D5391-93 or D4195-88 for measuring water purity.

Distillation systems, as well as some types of reverse osmosis water purity systems, can produce water in the quality range specified. Tap water is not recommended as it may contain chlorine, which can deteriorate the stainless steel. Tap water may also have a high mineral content, which would produce a build-up of scale in the pan. High purity, ultra pure or milli-q water is not recommended as it is an extremely aggressive solvent and will deteriorate the stainless steel. High purity water has a resistance of above 1M to 18M Ohm. Even high purity water can contain bacteria and organic contaminants. Water should always be sterilized or treated with a decontaminant, safe for use with stainless steel as well as safe for the product, prior to being introduced into the humidity pan.

Caution Distilled or de-ionized water used in the humidity pan must be within a water quality resistance range of 50K to 1M Ohm/cm to protect and prolong the life of the stainless steel. Use of water outside the specified range will decrease the operating life of the unit and may void warranty. ▲

Filling the Humidity Pan (continued)

Fill the humidity pan to within 1/2 inch of the top with sterile, distilled water. Place the pan directly on the incubator floor to ensure optimum humidity and temperature response.

For applications requiring higher humidity conditions, the pan should be placed against the left side wall of the incubator. The ductwork has been modified for this purpose. Also, the CO₂ sample port may be capped to assist in achieving greater RH. In some ambients, this may cause condensation to form in the chamber.

Check the level and change the water frequently to avoid contamination. Do not allow the water level to fluctuate significantly. “Dry-outs” will have an adverse effect on the humidity level, as well as CO₂ calibration.

Connecting the CO₂ Gas Supply

Warning High concentrations of CO₂ gas can cause asphyxiation! OSHA Standards specify that employee exposure to carbon dioxide in any eight-hour shift of a 40-hour work week shall not exceed the eight-hour time weighted average of 5000 PPM (0.5% CO₂). The short term exposure limit for 15 minutes or less is 30,000 PPM (3% CO₂). Carbon dioxide monitors are recommended for confined areas where concentrations of carbon dioxide gas can accumulate. ▲

The CO₂ gas supply being connected should be industrial grade 99.5% pure and should not contain siphon tubes. Install a two-stage pressure regulator at the cylinder outlet. The high pressure gauge at the tank should have 0-2000 psig range and the low pressure gauge, at the incubator inlet, should have a 0-30 psig range. Input pressure to the incubator must be maintained at 15 psig (103.4 kPa), ±5 psig.

The incubator has a serrated fitting on the back of the cabinet to connect the gas supply. Refer to Figure 1-13. The fitting is labeled CO₂ Inlet. Make sure that the connection is secured with a clamp. Check fitting for leaks.

Connecting the CO₂ Gas Supply (cont.)

Warning This incubator is designed to be operated with CO₂ gas only. Connecting a flammable or toxic gas can result in a hazardous condition. Gases other than CO₂ should not be connected to this equipment. CO₂ gas cylinders have UN1013 labeled on the cylinder and are equipped with a CGA 320 outlet valve. Check the gas cylinder for the proper identification labels. The CO₂ gas supply being connected to the incubator should be industrial grade, 99.5% pure. Do not use CO₂ gas cylinders equipped with siphon tubes. A siphon tube is used to extract liquid CO₂ from the cylinder, which can damage the pressure regulator. Consult with your gas supplier to ensure that the CO₂ cylinder does not contain a siphon tube. Gas cylinders should also be secured to a wall or other stationary object to prevent them from tipping.

A two-stage CO₂ pressure regulator is required to be installed on the outlet valve of the gas cylinder. Input pressure to the incubator must be maintained at 15 psig (103.4 kPa), ± 5 psig, for proper performance of the CO₂ control system. (A single stage CO₂ pressure regulator will not maintain 15 psig.

If higher purity CO₂ is desired inside the incubator (greater than 99.5% pure), the pressure regulator should be constructed with a stainless steel diaphragm along with specifying the purity of the CO₂ from the gas supplier. Follow the manufacturer's instructions to ensure proper and safe installation of the pressure regulator on the gas cylinder. Consult your facility safety officer to ensure that the equipment is installed in accordance with the codes and regulations applicable in your area. ▲

Incubator Start-Up

Now that the incubator has been properly installed, connected to power, filled with water, humidity pan filled, and connected to gas supply, system setpoints can be entered. The following setpoints can be entered: temperature, over temperature, and CO₂.

Setting the Operating Temperature Setpoint

The temperature setpoint range is 10° to 55°C, settable to within 0.1°C. The lowest temperature the incubator can control is +5°C above the ambient temperature at the incubator's location.

This incubator is shipped from the factory with a temperature setpoint of 10°C. At this setting, all heaters are turned off.

To change the temperature setpoint:

1. Press the Mode key until the Set indicator lights.
2. Press the right arrow until Temp XX.X is displayed in the message display
3. Press the up/down arrow until the desired temperature setpoint is displayed.
4. Press Enter to save the setpoint.
5. Press the Mode key until the Run Indicator lights to go to Run mode.

Setting the Overtemp Setpoint

Caution The overtemp circuit is designed as a safety to protect the incubator only. It is not intended to protect or limit the maximum temperature of the cell cultures or customer's equipment inside the incubator if an overtemp condition occurs. ▲

The factory setting for the Overtemperature setpoint is 40°C. It can be set over a range of temp setpoint +0.5°C to 60°C. If the temperature setpoint is moved above the Overtemp setpoint, the Overtemp will automatically update to 1.0°C + the temp setpoint. It is recommended that the Overtemp setpoint be 1°C over the temp setpoint.

To set the Overtemp setpoint:

1. Press the Mode key until the Set indicator lights.
2. Press the right arrow until OTemp XX.X is displayed in the message display
2. Press the up/down arrow until the desired overtemperature setpoint is displayed.
3. Press Enter to save the setpoint.
4. Press the Mode key until the Run Indicator lights to go to Run mode.

Setting the CO₂ Setpoint

All T/C CO₂ cells are precalibrated at the factory at 37°C, high humidity, and 10% CO₂, settable to within 0.1% CO₂. Therefore, if a temperature setpoint of 37°C has been entered, the humidity pan filled, and the CO₂ control is to run between 0-10% with a T/C CO₂ sensor, the CO₂ setpoint may be entered immediately. Otherwise, it is important to allow the unit 12 hours to stabilize at the temperature setpoint before entering the CO₂ setpoint.

The CO₂ setpoint range is 0.0% to 20.0%. The incubator is shipped from the factory with a CO₂ setpoint of 0.0%. At this setting, all CO₂ control and alarms are turned off.

To change the CO₂ setpoint:

1. Press the Mode key until the Set indicator lights.
2. Press the right arrow until CO₂ XX.X is displayed in the message display
3. Press the up/down arrow until the desired CO₂ setpoint is displayed.
4. Press Enter to save the setpoint.
5. Press the Mode key until the Run indicator lights to go to Run mode.

Chart 1-1. Set Mode

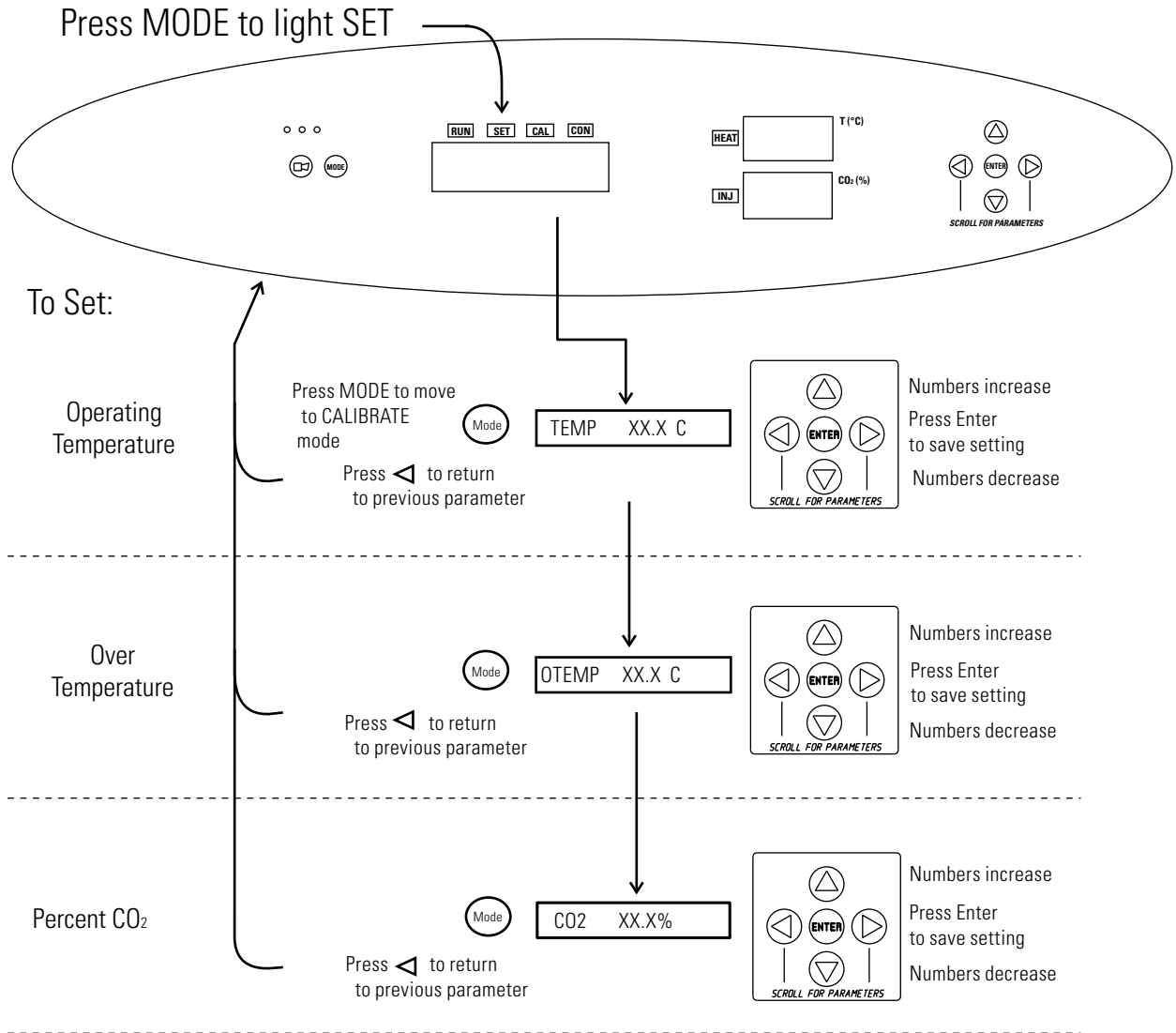

Section 2 Calibration

After the unit has stabilized, the air temperature and CO₂ display reading can be calibrated to reference instruments.

Calibration frequency is dependent on use, ambient conditions, and accuracy required. Good laboratory practice would require at least an annual calibration check. On new installations, all parameters should be checked after the stabilization period.

Prior to calibration, the user should be aware of the following system functions. While the unit is in Cal Temp Mode, temperature control is stopped so that chamber temperature remains stable. When the unit is in Cal CO₂ Mode, CO₂ control is stopped so that CO₂ levels remain stable. If no keys are pressed for approximately five minutes while in either of these two modes, the system resets to Run Mode so control can be reactivated.

Caution Before making an adjustment or calibration to the unit, it is imperative that all reference instruments be properly calibrated. ▲

Calibrating the Temperature

Place the calibrated instrument in the center of the chamber. The instrument should be in the airflow, not against the shelf. Before calibration, allow the cabinet temperature to stabilize.

Temperature Stabilization Periods

Start-Up - Allow 12 hours for the temperature in the cabinet to stabilize before proceeding.

Operating Unit - Allow at least two hours after the display reaches setpoint for the temperature to stabilize before proceeding.

1. Press the Mode key until the Cal indicator lights.
2. Press the right arrow until TEMPCAL XX.X is displayed in the message display
3. Press the up/down arrow to match the display to a calibrated instrument.
4. Press Enter to store the calibration into memory.
5. Press the Mode key to return to Run mode.

Calibrating T/C CO₂ System

Model VWR51014995 (VWR part number 10810-744) has a thermal conductivity (T/C) CO₂ sensor. Thermal conductivity of the incubator atmosphere is not only effected by the quantity of CO₂ present, but also by the air temperature and the water vapor present in the incubator atmosphere. In monitoring the effects of CO₂, air temperature and absolute humidity must be held constant so any change in thermal conductivity is caused only by a change in CO₂ concentration.

Changing temperature or changing from elevated humidity levels to room ambient humidity levels would necessitate a recalibration of the CO₂ control.

T/C CO₂ Sensor Stabilization Periods

Note Some T/C CO₂ sensors go through an aging period, especially on new installations. Calibration should be checked on a weekly basis, and adjusted as necessary. When stabilization occurs, checks may become less frequent. ▲

Start-up - The CO₂ sensor has been calibrated at the factory for 37°. Allow temperature, humidity, and CO₂ levels in the chamber to stabilize at least 12 hours before checking the CO₂ concentration with an independent instrument.

Presently operating - Make sure the chamber doors are closed. Allow at least 2 hours after the temperature and CO₂ displays reach their setpoints for chamber atmosphere stabilization.

1. Make sure stabilization periods outlined above are followed.
2. Sample the chamber atmosphere through the sample port with an independent instrument. Sample the atmosphere at least 3 times to ensure the accuracy of the instrument.
3. Press the Mode key until the Cal indicator lights.
4. Press the right arrow until CO@ CAL XX.X is displayed in the message display.
5. Press the up/down arrow to change the display to match the independent instrument.
6. Press Enter to store calibration.
7. Press the Mode key to return to Run Mode.

Calibrating IR CO₂ System

Model VWR51014996 (VWR part number 10810-878) has an infra-red (IR) CO₂ sensor. Infra-red CO₂ sensors are not effected by chamber atmosphere temperature or humidity. However, the light detector in the sensor is effected by wide temperature changes. Therefore, changing temperature setpoints could necessitate a recalibration of the CO₂. Chamber temperature should be allowed to stabilize before checking CO₂ concentrations with an independent instrument, especially on start-up.

Models equipped with an IR/CO₂ sensor have an automatic calibration that occurs every 24 hours, and lasts for 5 to 6 minutes. During automatic calibration, the CO₂ display is blanked out and filtered room air is pumped through the CO₂ sensor. A new CO₂ calibration value is stored in memory for use as the 0.0% CO₂ reference point. The keypad/ control panel is locked during calibration, with the message center reading CO₂ AUTO CAL.

Start-up- Allow the temperature and the CO₂ of the cabinet to stabilize at least 12 hours before proceeding.

Operating Unit - Allow CO₂ to stabilize at least 2 hours at setpoint before proceeding.

To ensure accurate calibration, the unit will not allow CO₂ to be spanned below 3%. If the cabinet does not contain at least 3% CO₂, increase the setpoint and allow the unit to stabilize before completing this procedure.

1. Measure the CO₂ concentration in the chamber through the gas sample port with a Fyrite or other independent instrument. Several readings should be taken to ensure accuracy.
2. Press the Mode key until the CAL indicator lights.
3. Press the right arrow until IR CAL XX.X appears in the message center.
4. Press the up/down arrow to adjust the display to match the independent instrument reading.
5. Press Enter to store calibration.
6. After Enter is pressed, the unit will go into a calibration cycle that lasts 5 to 6 minutes. Control panel is locked during this calibration cycle.
7. Press the Mode key to return to Run Mode.

Chart 2-1. Calibration Mode

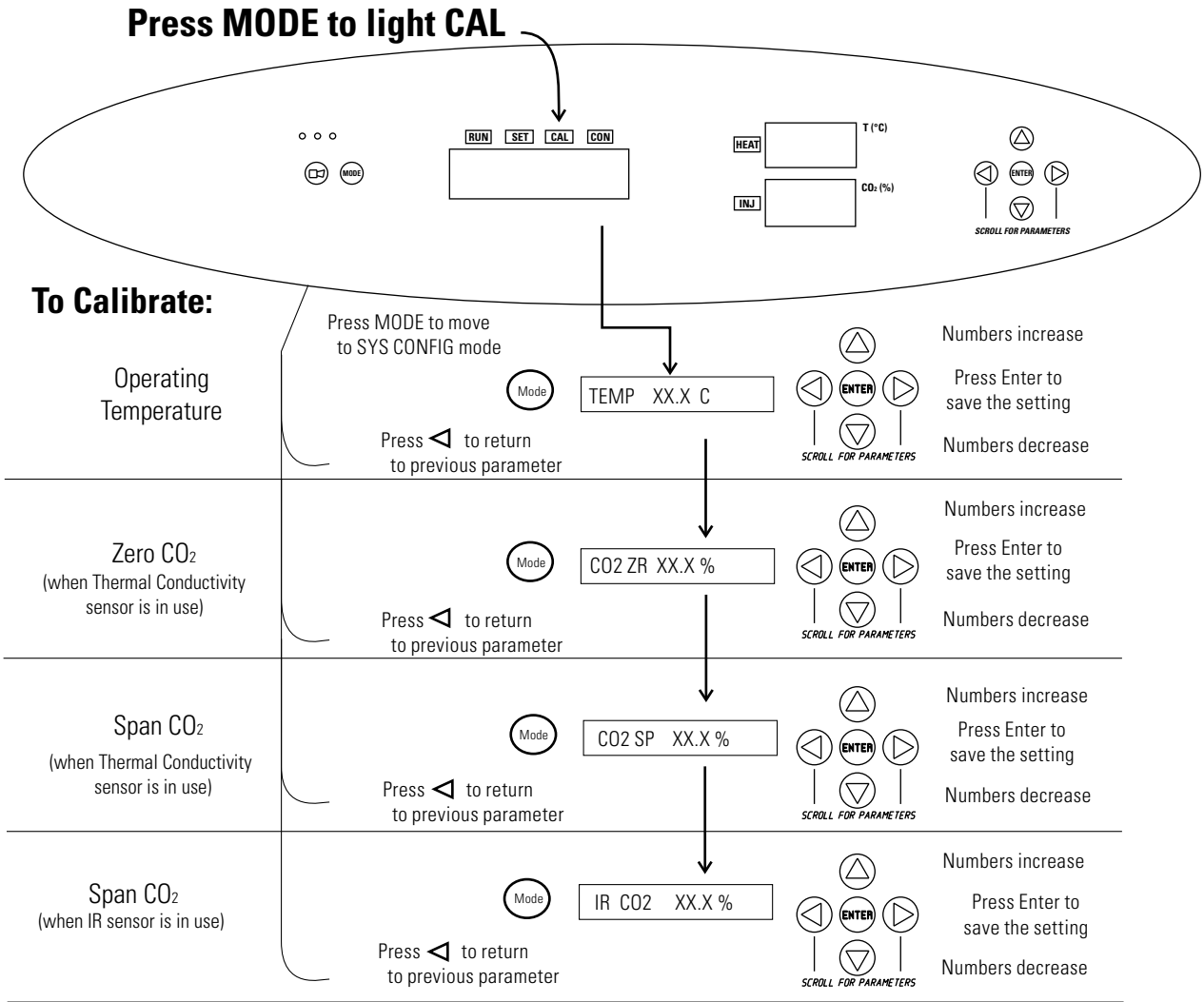

Section 3 Configuration

Several features available in Configuration mode allow custom setup of the incubator. These features are listed with descriptions below. All features may not be necessary in all applications, but are available if needed. To enter Configuration mode, press the MODE key until the CON indicator lights. Press the right and/or left arrow until the appropriate parameter appears in the message display. See Chart 3-1 for more detail.

Turn Audible Alarm ON/OFF

The audible alarm can be turned on or off. The factory setting is ON.

1. Press the MODE key until the CON indicator lights.
2. Press the right arrow until AUDIBLE XXX shows in the message display.
3. Press the up/down arrow to toggle AUDIBLE ON/OFF.
4. Press ENTER to save the setting.
5. Press the MODE key to return to RUN mode or right/left arrow to go to next/previous parameter.

New HEPA Filter

When the REPLACE HEPA reminder displays and the visual alarm flashes, the specified time has elapsed and the HEPA filter should be replaced. To clear the display and reset the timer after replacing the HEPA filter with a new one, follow the steps below.

1. Press the MODE key until the CON indicator lights.
2. Press the right arrow until NEW HEPA shows in the message display.
3. Press ENTER to restart the timer and clear the REPLACE HEPA alarm.
4. Press the MODE key to return to RUN mode.

Set REPLACE HEPA filter reminder

A HEPA filter replacement timer can be set for a specific amount of time, from 1 to 12 months of actual unit running time. Time will not accrue when the unit is turned off. The default time is 6 months. When the allotted time runs out, REPLACE HEPA appears in the display and the visual alarm flashes. To set the reminder, use the following procedure.

1. Press the MODE key until the CON indicator lights.
2. Press the right arrow until REPL HEPA XX is displayed.
3. Press the up/down arrow to choose the number of months desired.
4. Press ENTER to save the number.
5. Press the MODE key to return to RUN mode or right/left arrow to go to next/previous parameter.

Note After the reminder has been set, check the allotted time remaining by going to Configuration mode, then pressing the right arrow until NEW HEPA XXX displays. This number is the remaining days before the filter replacement time specified runs out. For example, if 12 months was chosen in the REPL HEPA XX message display, the NEW HEPA number would be 365 days. ▲

Set Access Code

A 3-digit Access Code can be entered to avoid unauthorized personnel from changing the setpoints, calibration, or configuration. A setting of 000 bypasses the access code. The factory setting is 000.

1. Press the MODE key until the CON indicator lights.
2. Press the right arrow until ACC CODE XXX shows in the message display.
3. Press up/down arrow to change the access code.
4. Press ENTER to save the access code.
5. Press the MODE key to return to the RUN mode or right/left arrow to go to next/previous parameter.

Set Low Temp Alarm Limit (tracking alarm)

The low temp alarm limit is the deviation from the temperature setpoint which causes a low temp alarm. The low temp alarm is variable from 0.5° below setpoint to 5° below setpoint. The factory setting is 1° below setpoint. A minus sign (-) in the display indicates that the alarm setting is below the setpoint.

1. Press the MODE key until the CON indicator lights.
2. Press the right arrow until TEMP LO -X.X shows in the message display.
3. Press up/down arrow to change the low temp alarm limit.
4. Press ENTER to save the low temp alarm limit.
5. Press the MODE key to return to RUN mode or right/left arrow to go to next/previous parameter.

Enable Low Temp Alarm to Trip Contacts

The low temperature alarm can be programmed to trip the remote alarm contacts. A setting of ON allows this, an OFF setting blocks the low temp alarm from tripping the contacts. The factory setting is ON.

1. Press the MODE key until the CON indicator lights.
2. Press the right arrow until TMP RLY XXX displays.
3. Press the up/down key to toggle the setting ON/OFF.
4. Press ENTER to save the setting
5. Press the MODE key to return to RUN mode, or the right/left arrow to go to next/previous parameter.

Set Low CO₂ Alarm Limit (tracking alarm)

The low CO₂ alarm limit is the deviation from the CO₂ setpoint which will cause a low CO₂ alarm. The setpoint is variable from 0.5% CO₂ below setpoint to 5.0% CO₂ below setpoint. The factory setting is 1.0% CO₂ below setpoint. A minus sign (-) in the display indicates that the alarm setting is below the setpoint.

1. Press the MODE key until the CON indicator lights.
2. Press the right arrow until CO₂ LO -X.X shows in the message display.
3. Press up/down arrow to change the low CO₂ alarm limit.
4. Press ENTER to save the low CO₂ alarm limit.
5. Press the MODE key to return to RUN mode or right/left arrow to go to next/previous parameter.

Set High CO₂ Alarm Limit (tracking alarm)

The high CO₂ alarm limit is the deviation from the CO₂ setpoint which will cause a high CO₂ alarm. The setpoint is variable from 0.5% CO₂ above setpoint to 5.0% CO₂ above setpoint. The factory setting is 1.0% CO₂ above setpoint.

1. Press the MODE key until the CON indicator lights.
2. Press the right arrow until CO₂ HI X.X shows in the message display.
3. Press up/down arrow to change the high CO₂ alarm limit.
4. Press ENTER to save the high CO₂ alarm limit.
5. Press the MODE key to return to RUN mode, or right/left arrow to go to next/previous parameter.

Enable CO₂ Alarms to Trip Contacts

High and Low CO₂ alarms can be programmed to trip the remote alarm contacts. A setting of ON allows this, a setting of OFF blocks CO₂ alarms from tripping the contacts. The factory setting is ON.

1. Press the MODE key until the CON indicator lights.
2. Press the right arrow until CO₂ RLY XXX shows in the message display.
3. Press up/down arrow to toggle the setting ON/OFF.
4. Press ENTER to save the setting.
5. Press the MODE key to return to RUN mode or right/left arrow to go to next/previous parameter.

Set New Zero Number for T/C CO₂ Sensors

If a new T/C CO₂ sensor is being installed, the two numbers on the factory installed sticker on the T/C cell must be entered to calibrate CO₂ in the unit.

Note For the technician's convenience, a label containing the two numbers on the T/C cell is affixed inside the electronics drawer. ▲

1. Press the MODE key until the CON indicator lights.
2. Press the right arrow until T/CZ# XXXX shows in the message display.
3. Press up/down arrow to change the zero number to match the sticker.
4. Press ENTER to save the setting.
5. Press the MODE key to return to RUN mode or right/left arrow to go to next/previous parameter.

Set New Span Number for T/C CO₂ Sensors

If a new T/C CO₂ sensor is being installed, the two numbers on the factory installed sticker on the T/C cell must be entered to calibrate the CO₂ in the unit.

Note For the technician's convenience, a label containing the two numbers on the T/C cell is affixed inside the electronics drawer. ▲

1. Press the MODE key until the CON indicator lights.
2. Press the right arrow until T/CS# XXXX shows in the message display.
3. Press up/down arrow to change the span number to match the sticker.
4. Press ENTER to save the setting.
5. Press the MODE key to return to RUN mode or right/left arrow to go to next/previous parameter.

Chart 3-1. Configuration Mode Page 1 of 2

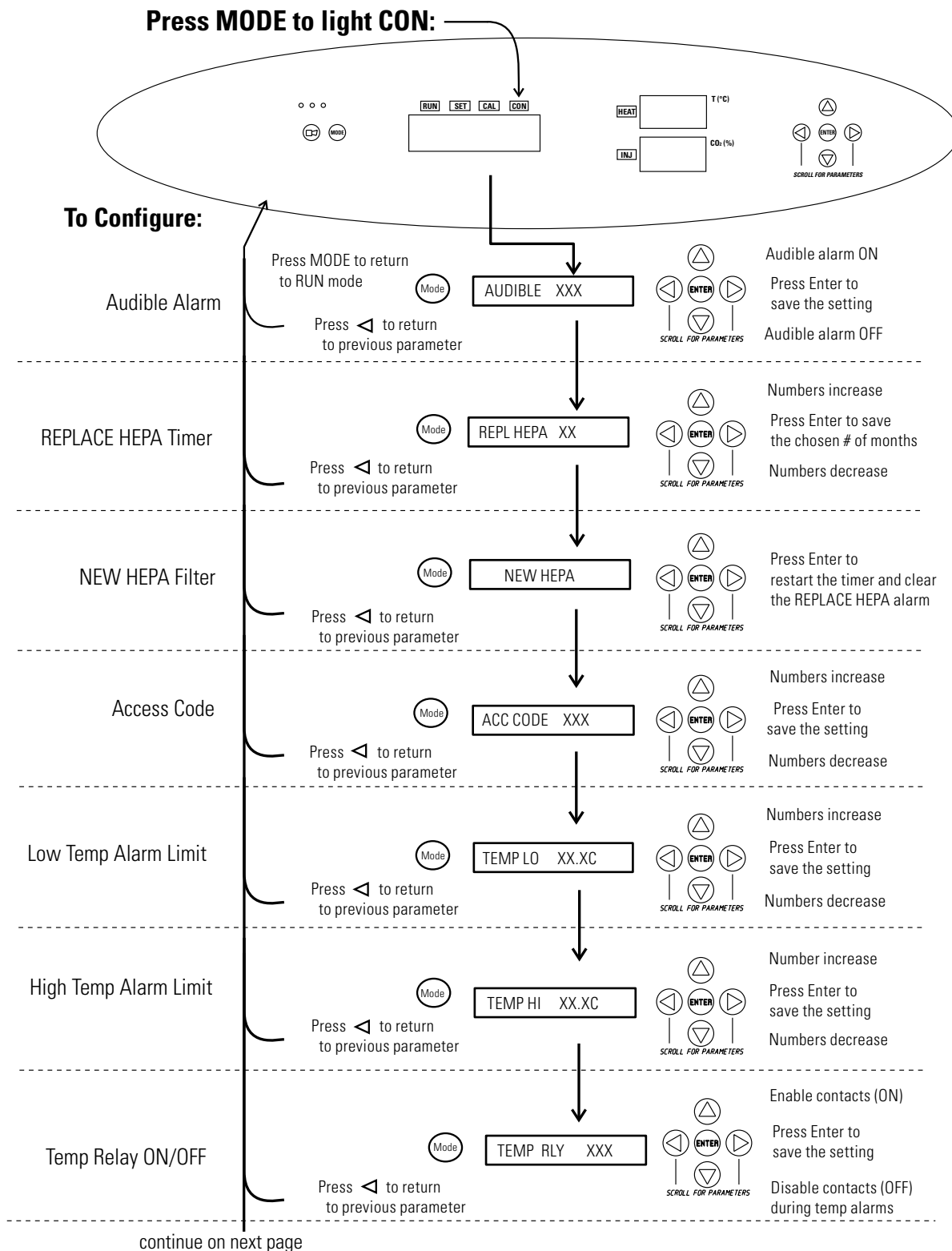
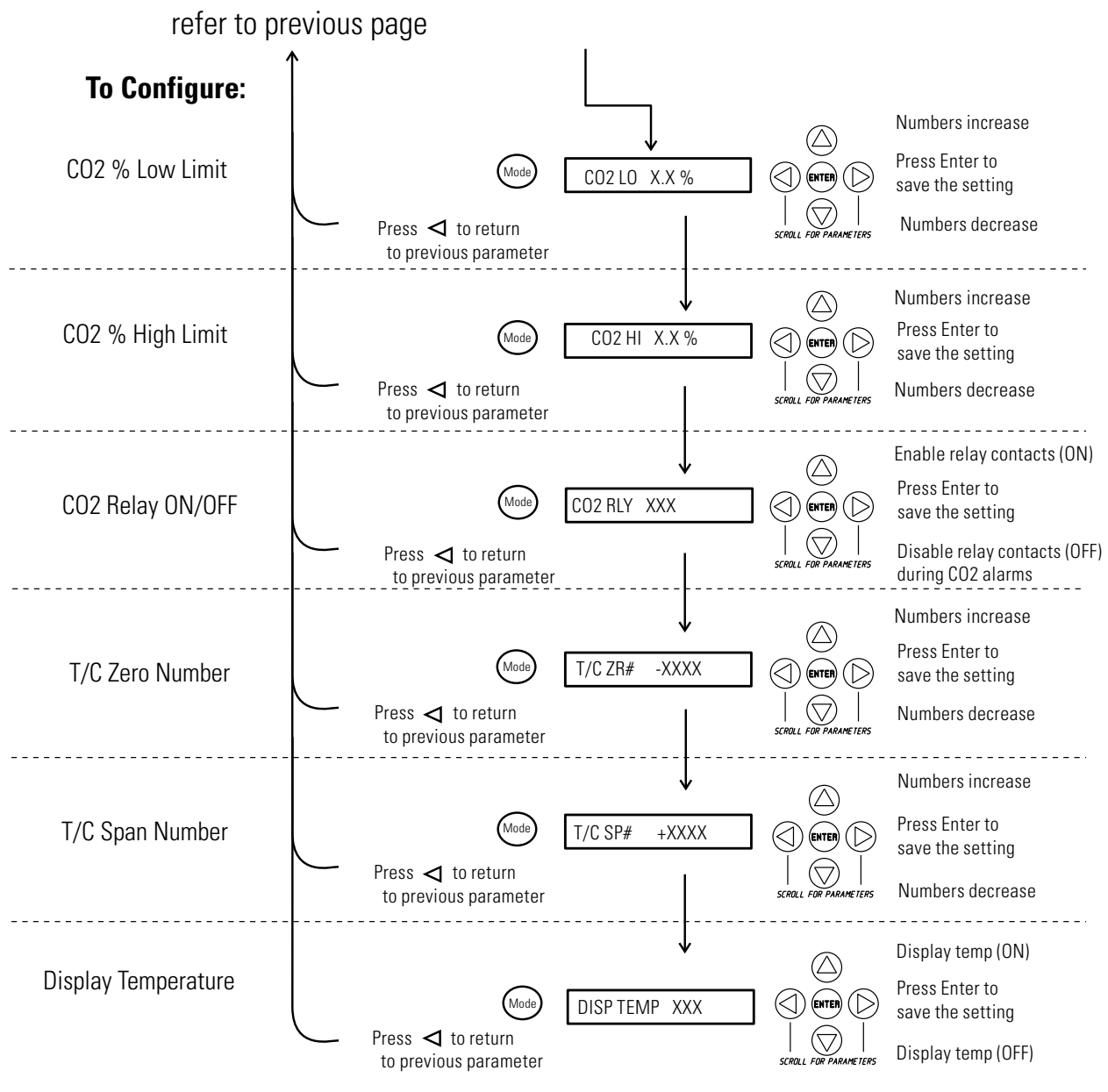

Chart 3-1. Configuration Mode Page 2 of 2



Section 4 Alarms

The incubator's alarm system is shown in the table below. When an alarm is active, the LED next to the alarm condition flashes. Pressing Silence causes all active alarms to be silenced for the ringback period. However, the visual alarm continues until the incubator returns to a normal condition. The alarms are momentary alarms only. When an alarm condition occurs and then returns to normal, the incubator automatically clears the alarm condition.

Temperature alarms are disabled when the temp setpoint is 10.0°C. CO₂ alarms are disabled when the CO₂ setpoint is 0.0%. The Low Temp alarm delay is set to 9 hours automatically on system power-up. This allows the user to avoid nuisance alarms when the system is first turned on. If the temp comes within the alarm limits prior to the 9 hour delay, the alarms will be enabled.

Table 3-1. Alarms

Alarm	Description	Delay	Ring-back	Trips Remote Alarm Contacts
Over Temp	Temperature is greater than Over Temperature setpoint	0 min.	15 min.	Yes
Low Temp	Temperature is at least 1°C lower than the temperature setpoint	15 min.	15 min.	Yes
High CO ₂	CO ₂ is at least 1% higher than the CO ₂ setpoint	15 min.	15 min.	Yes
Low CO ₂	CO ₂ is at least 1% lower than the CO ₂ setpoint	15 min.	15 min.	Yes
Add Water	Water is low in jacket	0 min.	15 min.	No
Door Open	Inner glass door is open	15 min.	15 min.	No
*Temp Display Flashes (Run Mode)	Temperature sensor failure	0 min.	15 min.	No
*CO ₂ Display Flashes (Run Mode)	CO ₂ sensor failure	0 min.	15 min.	No

* The microprocessor in the incubator continually scans the sensors to ensure they are operating properly. Should an error be detected, the affected display flashes and the alarm sounds. If such an alarm occurs, contact Technical Services.

All alarm delays and ringback times are ±30 seconds.

Preventive Maintenance

Refer to Manual Section	Action	Daily	Weekly	Monthly	3 to 6 Months	Yearly
--	Check CO ₂ tank levels.	✓				
--	Inspect door latch, hinges and door gasket seal.					✓
1	Check water level in the humidity pan, ½" from top.		✓			
2	Verify and document CO ₂ , humidity and temperature calibration, as applicable (See Calibration).					✓
	Disinfect the interior of the incubator (See Routine Maintenance).				✓	
1	Replace HEPA, access port filter, air sample filter, and CO ₂ filters*, if applicable (or as needed).					✓
5	Perform sterilization cycle as needed.					

Section 5 Routine Maintenance

Warning If the unit has been in service, turn it off and disconnect the power cord connector before proceeding with any maintenance. ▲

Caution Before using any cleaning method except those recommended by the manufacturer, users must check with the manufacturer that the proposed method will not damage the equipment. ▲

Use an appropriate disinfectant. All articles and surfaces must be thoroughly cleaned, rinsed with sterile water, and rough-dried.

Warning Alcohol, even a 70% solution, is volatile and flammable. Use it only in a well-ventilated area that is free from open flame. If any component is cleaned with alcohol, do not expose the component to open flame or other possible hazard. Do not spray the T/C sensor with flammable solutions. The internal temperature of the CO₂ sensor is approximately 150°C when the unit is in operation. Allow sufficient time for the sensor to cool before cleaning.

Do not use strong alkaline or caustic agents. Stainless steel is corrosion resistant, not corrosion-proof. Do not use solutions of sodium hypochlorite (bleach) as they may also cause pitting and rusting. ▲

A HEPA filter replacement kit (see Parts List) should be on-hand prior to cleaning the incubator interior.

Clean Chamber Interior

1. Remove the shelves, access port filter assembly, HEPA filter, air sample filter and tubing, and the left and right duct sheets. Discard the HEPA filters and the access port filter assembly. See Figure 5-1.

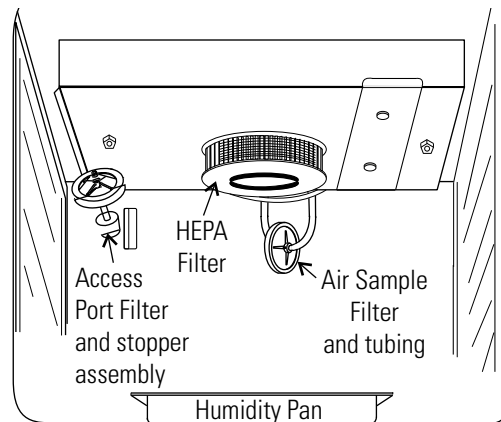

Figure 5-1. Component Locations

2. Wash the air sample filter tubing, shelves, and ducts with disinfectant, then rinse with sterile water. Optionally, the shelves and ducts may be autoclaved.
3. Wash the inner door gasket with disinfectant. This gasket may be removed to be cleaned, or replaced.
4. Wash the cabinet interior with disinfectant, starting at the top and working down. Refer to the disinfectant directions for length of time needed before rinsing. Wash the inner door both inside and out. The cabinet and door must be rinsed with sterile water until the disinfectant has been removed. After the cabinet has been rinsed, spray with 70% alcohol.
5. Install the left and right ducts, inner door gasket, access port filter assembly, and air sample filter and tubing, spraying each with 70% alcohol.
6. Install a new HEPA filter.
7. Install the shelves and spray with 70% alcohol.

Clean Cabinet Exterior

Clean the incubator exterior with a damp sponge or soft, well-wrung cloth and mild detergent dissolved in water. Dry with a soft cloth.

Clean Glass Doors

The chamber glass door and the optional independent inner glass doors may be cleaned using the same disinfectant as used on the incubator interior. It is imperative that they be rinsed with sterile distilled water to remove the disinfectant residue. The doors should then be dried with a soft cloth.

Some precautions in the cleaning and care of the incubator glass doors: Moisture leaches alkaline materials (sodium, Na) from the surface of the glass. Evaporation of the moisture concentrates the alkaline and may produce a white staining or clouding of the glass surface. Cleaning chemicals with a PH above 9 and heat (autoclaving) accelerate the corrosion process. Therefore, it is very important to rinse and dry the glass doors after cleaning. Autoclaving the glass doors should be avoided.

There is no simple method for repairing corroded glass. In most cases, the glass must be replaced.

Clean Humidity Pan

Clean the humidity pan with soap and water and a general-use laboratory disinfectant. Rinse with sterile water and spray with 70% alcohol. The pan may be autoclaved.

HEPA Filter Maintenance

Replace the HEPA filter when the REPLACE HEPA reminder is displayed. The REPLACE HEPA reminder can be set to alarm after a specified time from 1 to 12 months. The reminder default is the factory recommended setting of 6 months. For details, see Section 3.

Replace Power Fuses

To access the only replaceable fuse in the incubator:

1. Turn off the incubator's power switch and unplug the power cord.
2. Remove the two screws from the top of the control panel. Grasp the control panel on each side and pull straight outward.
4. Figure 5-3 shows the location of the fuse. See Table 5-1 following for replacement fuse specifications.
5. Secure the control panel and return the unit to service. If the fuse blows after restoring power to the incubator, contact your local distributor.

Table 5-1. Fuse Replacement Chart

Fuse Voltage	Manufacturer's P/N	Amperage Rating	Rupture Speed	IEC Letter Code
115VAC	BUSS GMC-1.0A	1.0 Amp	Time-Lag	T

Replace Air Sample Filter

1. Connect one end of the air sample filter to the hose barb on the chamber ceiling.
2. Connect the other end of the filter to the metal tubing on the HEPA filter adapter (Figure 5-2).

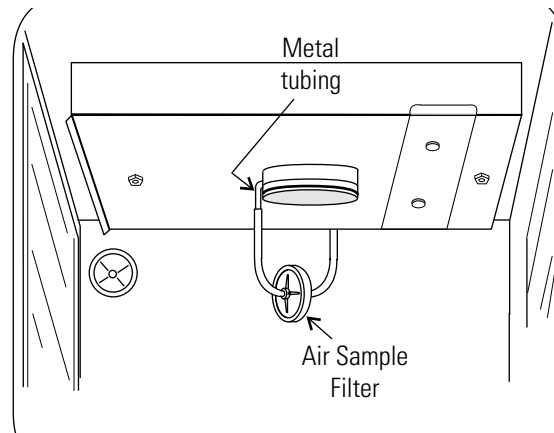

Figure 5-2. Connect to Metal Tubing

Section 6 Factory Options

A description of the factory option connections to external equipment follows.

Remote Alarms

A set of relay contacts is provided to monitor alarms through an RJ11 telephone style connector on the back of the cabinet. Refer to Figure 6-5 for the location of the alarm connector. The 12-foot telephone cord (P/N 190388) and RJ11-to-screw terminal conversion box (P/N 190392) are available through your local distributor.

The remote alarm provides a NO (normally open) output, an NC (normally closed) output and COM (common). Refer to Figure 6-1.

The contacts will trip on a power outage or an overtemperature condition. The contacts may also be programmed to trip or not trip on temperature alarms, CO₂ alarms, and RH alarms. See Section 3, Configuration mode.

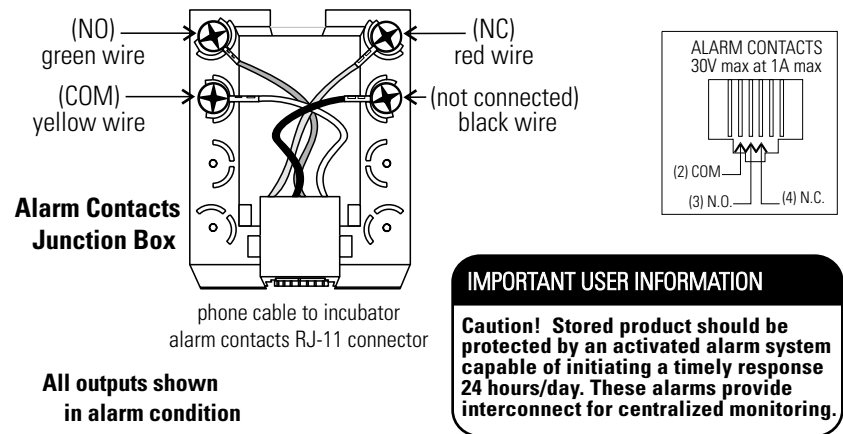

Figure 6-1. Remote Alarm Contacts



Section 7 Specifications

*Specifications are based on nominal voltages of 115V in ambients of 22°C to 25°C.

Temperature

Control±0.1°C
Range+5°C above ambient to +55°C (131°F)
Uniformity±0.3°C @ +37°C
Low Temp Tracking Alarm Fixed at 1.0°C below setpoint

Temperature Safety

SensorPrecision thermistor
Setability0.1°C

CO₂

CO ₂ ControlBetter than ±0.1%
CO ₂ Range0-20%
Inlet Pressure15 PSIG (1.034 bars), ±5 PSIG
CO ₂ SensorT/C
Readability0.1%
Setability0.1%
Low CO ₂ Tracking Alarm Fixed at 1.0% below setpoint
High CO ₂ Tracking Alarm Fixed at 1.0% above setpoint

Humidity

RHAmbient to 95% @ +37°C (98.6°F)
Humidity Pan0.8 gal. (3 liters) standard

Fittings

Fill Port3/8" barbed
Drain Port1/4" barbed
Access Port1-1/4" (3.18cm) removable neoprene plug
CO ₂ Inlet1/4" hose barbed

Unit Heat Load

115V344 BTUH (100 Watt)

Shelves

Dimensions18.5” x 18.5” (47.0cm x 47.0cm)

ConstructionStainless steel, perforated

Surface area2.4 sq. ft. (0.22 sq. m) per shelf

Max. per Chamber38.4 sq. ft. (3.6 sq. m)

Loading 35 lbs (16kg) slide in and out, 50 lbs (23kg) stationary

Standard3

Maximum16

Construction

Water Jacket Volume11.7 gal. (43.5 liters)

Interior Volume6.5 cu. ft. (184.1 liters)

InteriorStainless steel

Exterior18 gauge, cold rolled steel, powder coated

Outer Door GasketFour-sided, molded magnetic vinyl

Inner Door Gasket . .Removable, cleanable, feather-edged, silicone

Electrical

115V90-125VAC, 50/60 Hz, 1 PH, 3.6 FLA

Circuit Breaker/Power Switch6 Amp/2 Pole

Alarm Contacts . .Power interruption, deviation of temp., CO₂ customer connections through jack on back of unit. 30V, 1A max.

Installation CategoryOvervoltage Category II

Pollution Degree 2

Maximum Leakage CurrentWith ground disconnected, 0.65mA

Maximum permissible leakage, 3.5mA

Dimensions

Interior21.3” W x 26.8” H x 20.0” F-B

.....(54.1cm x 68.1cm x 50.8cm)

Exterior26.3” W x 39.5” H x 25.0” F-B

.....(66.8cm x 100.3cm x 63.5cm)

Weight (per unit)

Net265 lb. (120.2 kg)
Net Operational365 lb. (165.6 kg)
Shipping324 lb. (147.0 kg)

Safety Specifications

Indoor use only

Altitude2000 meters

Temperature5°C to 40°C

Humidity80% RH at or below 31°C,
.decreasing linearly to 50% RH at 40°C

Mains Supply Fluctuations . . Operating Voltage Range

Installation Category 2¹

Pollution Degree 2²

Class of Equipment

¹ Installation category (overvoltage category) defines the level of transient overvoltage which the instrument is designed to withstand safely. It depends on the nature of the electricity supply and its overvoltage protection means. For example, in CAT II which is the category used for instruments in installations supplied from a supply comparable to public mains such as hospital and research laboratories and most industrial laboratories, the expected transient overvoltage is 2500V for a 230V supply and 1500V for a 120V supply.

² Pollution Degree describes the amount of conductive pollution present in the operating environment. Pollution Degree 2 assumes that normally only non-conductive pollution such as dust occurs with the exception of occasional conductivity caused by condensation.

Section 8 Customer Installed Accessories and Parts

VWR Part Number	Description
98000-392	Stainless steel shelf and channels
10065-492	HEPA filter, 5.5” diameter
97025-844	HEPA filter replacement kit
10820-346	Roller base
98000-386	Dolly

VWR CO2 INCUBATOR WARRANTY - NORTH AMERICA

VWR warrants this product for a period of 3 years from date of delivery. If component parts are non-conforming in materials and workmanship VWR will repaired or replaced during the warranty period.

Installation and calibration is not covered by this warranty agreement. This warranty does not apply if the product has been damaged by accident, abuse, misuse, or misapplication, or from ordinary wear and tear. Expendable items, glass, filters, and gaskets are excluded from this warranty.

THIS WARRANTY IS EXCLUSIVE AND IN LIEU OF ALL OTHER WARRANTIES, WHETHER WRITTEN, ORAL, OR IMPLIED. NO WARRANTIES OF MERCHANTABILITY OR FITNESS FOR A PARTICULAR PURPOSE SHALL APPLY. Items being returned must be insured by the customer against possible damage or loss. This warranty shall be limited to the aforementioned remedies.

Rev. 0 1/2016



