

GE Healthcare

Monitor UV-900

User Manual



Important user information

All users must read this entire manual to fully understand the safe use of Monitor UV-900.

WARNING!



The WARNING! sign highlights instructions that must be followed to avoid personal injury. It is important not to proceed until all stated conditions are met and clearly understood.

CAUTION!

The Caution! sign highlights instructions that must be followed to avoid damage to the product or other equipment. It is important not to proceed until all stated conditions are met and clearly understood.

Note

The Note sign is used to indicate information important for trouble-free and optimal use of the product.

CE Certifying

This product meets the requirements of applicable CE directives. A copy of the corresponding Declaration of Conformity is available on request.

The CE symbol and corresponding declaration of conformity, is valid for the instrument when it is:

- used as a stand-alone unit, or
- connected to other CE-marked GE Healthcare instruments, or
- connected to other products recommended or described in this manual, and
- used in the same state as it was delivered from GE Healthcare except for alterations described in this manual.

Recycling



This symbol indicates that the waste of electrical and electronic equipment must not be disposed as unsorted municipal waste and must be collected separately. Please contact an authorized representative of the manufacturer for information concerning the decommissioning of equipment.

WARNING!

This is a Class A product. In a domestic environment this product may cause radio interference in which case the user may be required to make adequate measures

Contents

1	Introduction	
1.1	General	7
1.2	Safety	8
2	Installation	
2.1	Unpacking	9
2.2	General precautions	9
2.3	Installing the flow cell	10
2.3.1	<i>Fixing the flow cell</i>	10
2.3.2	<i>Connecting the optical fibers</i>	11
2.4	Connecting electrical signal cables	12
2.4.1	<i>Connecting to recorder (if used)</i>	12
2.5	Connecting to communication link	12
2.6	Connecting to supply voltage	13
2.7	Connecting the tubing	13
2.8	Mounting the cell holder cover	14
3	Operation	
3.1	On/off	15
3.2	Menu selection and settings	15
3.2.1	<i>Menu selection</i>	15
3.2.2	<i>Return to main menu</i>	16
3.2.3	<i>Select value</i>	16
3.3	Main menu overview	17
3.4	Setting lamp on/off	17
3.5	Reading absorbance values	18
3.6	Setting wavelength	18
3.7	Autozero	19
3.8	Storage and shut-down	19
3.9	Using an external chart recorder	20
3.9.1	<i>Setting range and zero</i>	20
3.9.2	<i>Event mark</i>	20
3.10	Filtering noise	21
3.11	UV cell calibration	22
3.12	Changing flow cell	24
3.13	Restart after power failure	24
4	Maintenance	
4.1	Periodic maintenance	25

4.2	Cleaning-in-place	25
4.3	Checking the instrument	26
4.3.1	<i>Lamp intensity</i>	26
4.3.2	<i>Lamp on-time</i>	26
4.3.3	<i>Flip time</i>	26
4.3.4	<i>UV flow cell</i>	26
4.4	Cleaning the flow cell and optical fiber connectors	27
4.4.1	<i>Cleaning the flow cell</i>	27
4.4.2	<i>Cleaning the optical fiber connectors</i>	27
4.4.3	<i>Instrument housing</i>	27
4.5Cleaning the system	27
4.6	Recycling	28
5	Trouble-shooting	
5.1	General	29
5.2	Faults and actions	29
5.3	Error messages	30
	Reference information	
A	Description	31
A.1	<i>Instrument</i>	31
A.2	<i>Flow cell</i>	32
A.3	<i>Monitor principle</i>	32
B	Menus	34
B.1	<i>Check menu</i>	34
B.2	<i>Setup menu</i>	36
B.3	<i>Setting and using the alarm timer</i>	37
B.4	<i>Service displays</i>	37
B.5	<i>Menu overview</i>	38
C	Technical specifications	39
D	Accessories and spare parts	42

Short instructions on side 39

About this manual

This manual comprises two parts; a practical part (sections 1–5) and a reference part (sections A–D).

Sections 1–5 contain the necessary information for operating the instrument.

1 Introduction

1.1 General

Monitor UV-900 is a UV-absorption monitor for use in liquid chromatography.

Monitor UV-900 features:

- Variable wavelength for detection in the range 190–700 nm.
- Up to 3 wavelengths can be monitored simultaneously.
- Two alternative flow cells with path length 2 mm and 10 mm.
- Accurate and reliable monitoring through self-test, self-calibration and fiber optics.

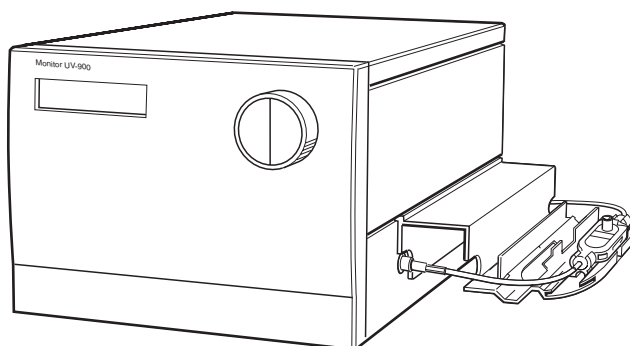

1.2 Safety

IMPORTANT! Monitor UV-900 is intended for laboratory use only, not for clinical or in vitro use, or for diagnostic purposes.

- The instrument is designed for indoor use only.
- Do not use in a dusty atmosphere or close to spraying water.



WARNING! When using hazardous chemicals, all suitable protective measures, such as protective glasses, must be taken.



WARNING! The instruments must not be opened by the user. They contain high voltage circuits which can give a lethal electric shock.



WARNING! The system must be connected to a grounded mains socket.



WARNING! Always disconnect the power supply before attempting to replace any item on the instrument.



WARNING! The instrument uses high intensity ultra-violet light. Do not disconnect the optical fibers while the monitor is running.

CAUTION! The flow cell must not be used at pressures above 2 MPa (20 bar, 290 psi). At higher pressures the flow cell may break.



WARNING! When using hazardous chemicals, take all suitable protective measures, such as wearing protective glasses and gloves resistant to the chemicals used. Follow local regulations and instructions for safe operation and maintenance of the system.



WARNING! There must always be a sample loop connected to ports 2 and 6 of the injection valve. This is to prevent liquid spraying out of the ports when switching the valve. This is especially dangerous if hazardous chemicals are used.



WARNING! This is a Class A product. In domestic environment this product may cause radio interference in which the user may be required to take adequate measures.

2 Installation

2.1 Unpacking

Unpack the instrument and check the items against the supplied packing list. Inspect the items for obvious damage which may have occurred during transportation.

- The system should be installed on a stable laboratory bench providing a suitable working area.
- To maintain correct ventilation, the system requires an appropriate amount of free space. Do not block the ventilation inlets or outlets on the system!

It is recommended that all packing materials should be retained if onward transport of the instrument is expected.

CAUTION! The following information should be read carefully to ensure that the instrument is installed correctly.

2.2 General precautions

The instrument should not be installed in a corrosive atmosphere or in an atmosphere where deposits are liable to form on the optical surfaces.

The instrument should be located in a place of low temperature variations, away from heat sources, draughts and direct sunlight.

The instrument may be operated at normal ambient temperatures in the range +4 to +40 °C.

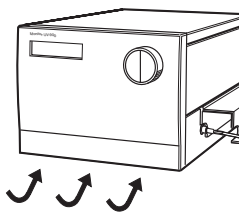

The instrument should be installed on a stable laboratory bench or in ÄKTA™ explorer or ÄKTApurifier. To ensure correct ventilation a free space of 0.1 m is required behind and in front of the instrument. Place the instrument directly on the bench. Do not use any soft material under the instrument, to ensure that the ventilation inlet in the front is not blocked.

2.3 Installing the flow cell

2.3.1 Fixing the flow cell

Handle the optical fibers with care, *do not bend excessively*.

Two flow cells are available: UV-900/2 with 2 mm light path length (cell volume 2 μ l) and UV-900/10 with 10 mm path length (8 μ l).

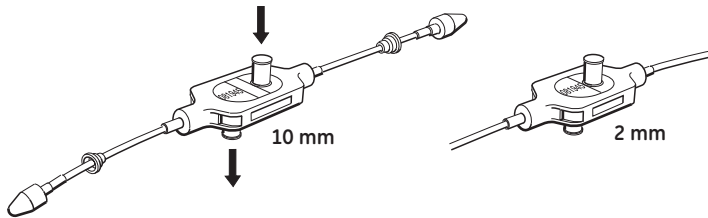

- 1 Unpack the flow cell. Do not remove the red protective caps from the inlet or outlet, or the black protective caps on the optical fiber connectors.
- 2 Slide the rear white clip on the cell holder to its inner position for a 2 mm cell and to its outer position for the 10 mm cell.

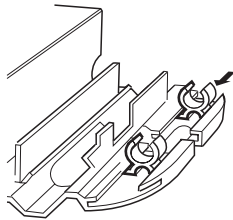

- 3 Place the flow cell in the opening between the white clips. The cell should be positioned with the text and serial number facing upwards and to the front. Press the cell into the clips to fasten it.

CAUTION! To avoid damaging the optical fibers, press only on the cell body, never on the optical fibers.

To improve the access to the tubing connections, the flow cell can alternatively be positioned with the tubing connections.

Normal position

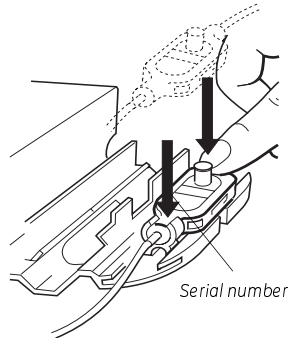

Alternative position

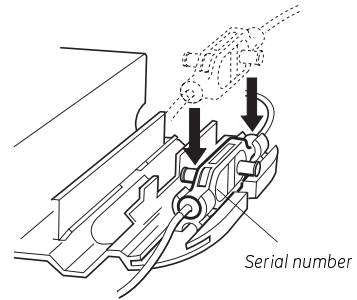

2.3.2 Connecting the optical fibers

- 1 Remove the 2 black protective caps from the optical fiber connectors.

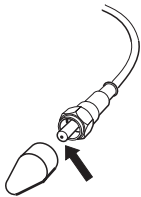

CAUTION! Do not touch the tips of the optical fibers with your fingers as this will result in poor monitor performance. If you accidentally touch the optical fiber tip, it can be wiped with 30% isopropanol using lens paper.

- 2 Remove the 2 rubber protective caps from the optical fiber receptacles on the right side of the housing.
- 3 Connect the 2 optical fibers to the housing by carefully inserting them into the sockets and tightening the nuts fingertight using the fiber detachment tool supplied.



Fiber detachment tool

CAUTION! Do not twist the optical fibers during tightening.

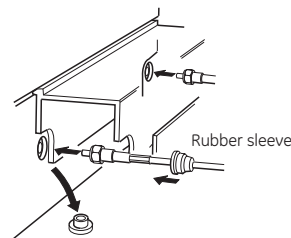

- 4 Slide the rubber sleeves on the 2 optical fibers onto the connectors. Make sure that the sleeves are pushed tight to the housing to prevent dust or fluid entering the connection.

2.4 Connecting electrical signal cables

The sockets for electrical signals are located on the back panel.

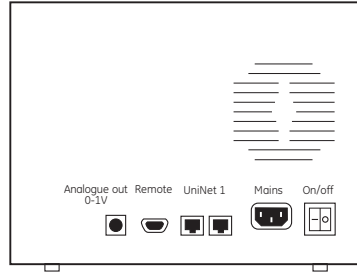

2.4.1 Connecting to recorder (if used)

- 1 Connect the recorder to the miniDIN-socket **Analogue out** using the cable supplied. Each wavelength signal is available on a separate channel using the following wires:

$\lambda 1$	Wire 1	+
	Wire 2	-
$\lambda 2$	Wire 3	+
	Wire 4	-
$\lambda 3$	Wire 5	+
	Wire 6	-

Note: The signal cable is delivered with protective covers on each wire. Do not remove the protective covers from unused connections as a short circuit may disturb the measurements.

- 2 Set the recorder to 0-1 V input, full scale, 0 V offset.

2.5 Connecting to communication link

The monitor can be used in ÄKTAexplorer or ÄKTApurifier and controlled from a PC running UNICORN™ version 3.21 or higher, using UniNet cables.

CAUTION! The mains power to the ÄKTAexplorer or ÄKTApurifier must be switched OFF before connecting the instrument to the UniNet-1 link.

WARNING! Only use mains cables delivered or approved by GE Healthcare.

WARNING! Do not block the rear panel of the system. The mains power switch must always be easy to access.



Connect two UniNet cables to the UniNet-1 connectors. The instrument can be connected in series anywhere in the chain between the PC and the termination plug. The UniNet-1 link connects, in series, the PC with Pump P-905, Monitor pH/C-900 and Monitor UV-900. The termination plug is connected to the last instrument in the chain.

2.6 Connecting to supply voltage

- 1 Make sure the on/off switch is in the OFF position (O).
- 2 Connect a mains cable between the instrument and a grounded mains socket. The instrument is delivered with both European and US type mains cables, as standard. Any voltage 100–240 V AC, 50–60 Hz, can be used.



WARNING! The instrument must be connected to a grounded mains socket.

The instrument contains no user replaceable fuse.

2.7 Connecting the tubing

- 1 Remove the red protective caps from the inlet and outlet of the flow cell and connect the tubing with 1/16" "fingertights".

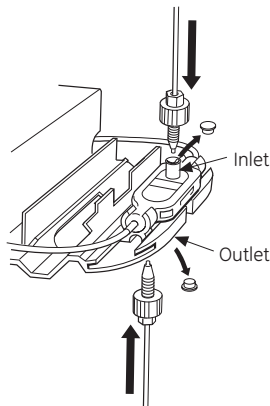

The inlet is on the top of the flow cell, the same side as the serial number.

2.8 Mounting the cell holder cover

The cover is a simple push fit onto the cell holder. Two small lugs on the cover locate in holes at the front and rear of the cell holder. The cover is then lowered over the cell holder.

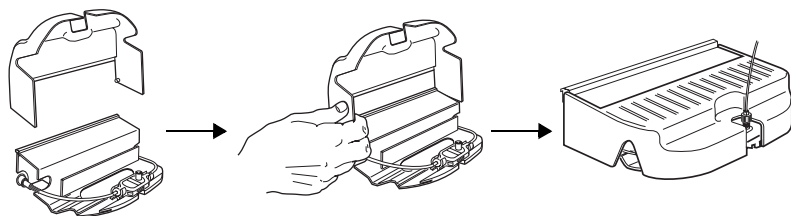

3 Operation

3.1 On/off

Selftest Please wait...

- 1 Switch on the instrument at the mains switch on the rear panel.

Calibrating Please wait...

- 2 The instrument performs a self-test and then starts calibration.

Please Check UV Cell! Press OK/Esc to cont.
--

- 3 If the instrument has a calibrated cell path length set that differs from the nominal length, a warning message appears on the monitor display. Another message, displaying the calibrated cell length, also appears. The display toggles between these messages.

Real UV Cell Length (?,??mm, SN?????)
--

- 4 To go to the *Main operating menu*, press **OK** or wait for about 45 seconds to return automatically.

$\lambda 1(215)$	1.123 AU
$\lambda 2(254)$	0.02345 AU

- 5 If no such warning messages appear, the display automatically shows the *Main operating menu* after approximately 1 minute. The instrument is ready to use.

All parameters are factory set to default values.

3.2 Menu selection and settings

3.2.1 Menu selection

A specific menu is selected by turning the front selection dial clockwise or counter clockwise. When the required menu is visible the menu or selection is accepted by pressing the **OK** button.

Menu selection

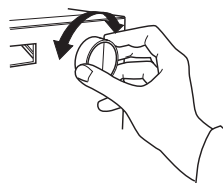

OK button
Select submenu

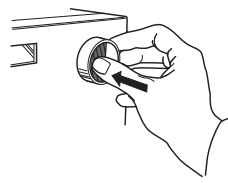

ESC button
Return one menu level

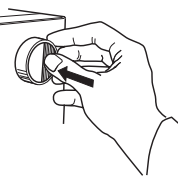

If a menu has sub levels, the sub menu is displayed by pressing the **OK** button. Pressing the **ESC** button moves back one menu level.

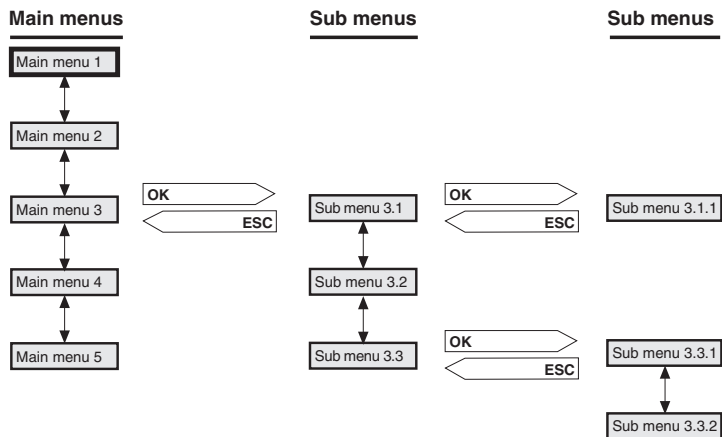

3.2.2 Return to main menu

Pressing **ESC** repeatedly, always returns to the **main menu 2** which is the main operating menu. Press **ESC** once more to return to **main menu 1**, the mode changing menu.



3.2.3 Select value

A cursor below a text or numerical value shows what is affected by the dial. To increase the value turn the dial clockwise. To decrease the value turn the dial counter clockwise.

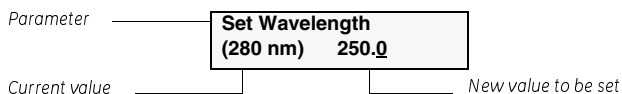

When setting numerical values, the cursor moves up to the next digit if the dial is turned quickly in one direction, to simplify entering large values. The cursor moves back one place to the right every two seconds if the dial is not turned. The text or numerical value displayed is accepted by pressing the **OK** button. To cancel, press the **ESC** button.

3.3 Main menu overview

Run Press OK to End	<i>Mode changing menu (mode menu).</i> The menu is accessed from all positions by pressing the ESC button repeatedly.
λ1(215) 1.123 AU λ2(254) 0.02345 AU	<i>Main operating menu 1.</i> Wavelength display showing first two wavelengths and, if the instrument is in Run mode, their absorbance.
λ3(280) 1.123 AU	<i>Main operating menu 2.</i> Wavelength display showing the third wavelength and, if the instrument is in Run mode, the absorbance.
Autozero	Autozero the instrument.
Eventmark	Produce event mark.
Set Wavelength (215, 254, 280 nm)	Set the wavelengths for the measurements.
Set Analogue Out (2.000AUFS, 10%)	Set the recorder output.
Set Averaging Time (2,56s)	Filtering noise.
Set UV Cell Length (--.-- mm, SN -----)	Flow cell path length calibration.
Check	Check internal operating values. See section <i>B.1 Check menu</i> .
Setup	Setup language, unit number etc. See section <i>B.2 Setup menu</i> .
Alarm/Timer 00:22:24	Set different timer options. See section <i>B.3 Setting and using the alarm timer</i> .

3.4 Setting lamp on/off

The lamp should be switched off when no measurement is made to conserve the lamp operating time. The lamp is switched on when a run is started. No warm-up time is required.

Current status

Run Press OK to End

- 1 Select the mode changing menu.
- 2 Switch the lamp on (**Run**) or off (**End**) by pressing **OK**. Its current status is shown in the upper left of the display.

When controlled from UNICORN, the lamp is switched on automatically when the flow is started and off when the run is ended.

$\lambda 1(215)$	1.123 AU
$\lambda 2(254)$	0.02345 AU

$\lambda 3(280)$	1.123 AU
------------------	----------

or

215nm	254nm	280nm
1.123	0.023	0.123

3.5 Reading absorbance values

The main operating menu shows the absorbance values for up to 3 active wavelengths. The menu is reached from any other menu by pressing the **ESC** button repeatedly. The display for the third wavelength is reached by turning the dial clockwise.

As an alternative all 3 wavelengths can be shown in a single display, but limited to 3 decimals. This alternative is reached by turning the dial clockwise.

3.6 Setting wavelength

The instrument can measure up to 3 wavelengths simultaneously and wavelength changes can be set at any time.

Set Wavelength (215, 254, 280 nm)

Set Wavelength $\lambda 1$ (215, 254, 280 nm)
--

Set Wavelength $\lambda 1$ (215nm) 234
--

Set Wavelength $\lambda 2$ (254nm)

- 1 Select main menu **Set Wavelength**, press **OK**.
- 2 Select sub menu **Set Wavelength $\lambda 1$** , press **OK**.
- 3 Set the value, press **OK**.
- 4 The next wavelength $\lambda 2$ is now shown. Set the value or turn the wavelength off, by turning the dial counter clockwise until the value passes through 190 nm. If only one wavelength is to be used, $\lambda 2$ and $\lambda 3$ should be set to off. Press **OK**.

The first wavelength $\lambda 1$ can never be set to off.

- 5 Repeat step 4 in the menu **Set Wavelength $\lambda 3$** .
- 6 Press **ESC** to return to the main operating menu.

In UNICORN, the wavelengths are set with the instruction **Wavelength** in **System Control:Manual:Alarm&Mon**.

3.7 Autozero

The autozero function sets the detected absorbance to zero when the **OK** button is pressed. All three wavelengths are autozeroed. Autozero is recommended after wavelength changes in a method and before the sample is injected.

Autozero

- 1 Select main menu **Autozero**, press **OK**. The normal absorbance value display is then shown.

In UNICORN, Autozero is set with the instruction **AutoZeroUV** in **System Control:Manual:Alarm&Mon.**

3.8 Storage and shut-down

Overnight: The flow cell can be left filled with buffer.

Weekend and long term storage: Flush the flow cell with distilled water and then fill it with 20% ethanol.

The flow cell can also be stored dry by flushing as above with distilled water and then blowing a compressed inert gas such as nitrogen (N₂) through the cell. Replace the red protective caps. Never use compressed air as this may contain droplets of oil.

CAUTION! Do not allow solutions which contain dissolved salts, proteins or other solid solutions to dry out in the flow cell. Do not allow particles to enter the flow cell as damage to the flow cell may occur.

3.9 Using an external chart recorder

3.9.1 Setting range and zero

The external chart recorder output from the instrument is always 0–1 V, but the absorbance value for full scale deflection and the Zero Absorbance level on the recorder can be set.

Set Analogue Out
(2.000AUFS, 10%)

- 1 Select main menu **Set Analogue Out**, press **OK**.

Set Range
(2.000AUFS) <0.1>

- 2 Set the range value in the sub menu **Set Range** and press **OK**. The range is the full scale absorbance range for the chart recorder (1 V). Only fixed steps between 5.0 AU and 0.01 AU can be set and the value is the same for all 3 wavelengths.

Set Zero Level
(10% of FS) 20

- 3 Select menu **Set Zero Level**, press **OK**.
- 4 Set the value and press **OK**. This value determines where the zero absorbance level should be in relation to full scale on the recorder.

The instrument has an automatic overrange function. If during a peak the monitor signal reaches the full scale value, the signal will drop instantly to 0 V and give an accurate display of the peak starting from this position.

3.9.2 Event mark

Event marks can be set, for example when the sample is injected, and displayed as spikes on all three channels of the chart recorder. The spikes are 10% of the full scale of the chart recorder which corresponds to 0.1 V.

- 1 Select main menu **Event mark**, press **OK**.

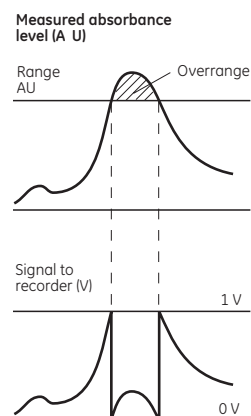

3.10 Filtering noise

To filter the noise in the UV-signal, a moving average filter is used. The averaging time is the time interval used for calculating the moving average of the absorbance signal. A long averaging time will smooth out noise efficiently, but it will also distort the peaks. Peaks narrower than the minimum peak width value may be distorted. Because of this the averaging time should be as short as possible, see the table below. On delivery the averaging time is set to 2.56 s.

- 1 Select menu **Set Averaging Time**, press **OK**.
- 2 Set the value, press **OK**. Use the fixed **values** between 5.12 and 0.08 s. When monitoring more than one wavelength, the recommended averaging time is a minimum of 1.28 s.

Set Averaging Time (2.56s)	<2.56>
---	---------------------

Averaging time (s)	Time constant (s) (approximate)	Min. peak width at half height (s)
5.12	2.0	32
2.56	1.0	16
1.28	0.5	8.0
0.64	0.2	3.2
0.32	0.1	1.6
0.16	0.05	0.8
0.08	0.03	0.5

In UNICORN the averaging time is set with the instruction **AveragingTime** in **System Control:Manual:Alarm&Mon.**

3.11 UV cell calibration

The path length in the UV flow cell might differ from the nominal length (1, 2, 5 respective 10 mm) which interferes the calculation of the protein concentration in the eluate. To achieve normalized absorbance, the path length in the UV flow cell must be calibrated.

It is recommended to calibrate a new UV flow cell before use. An old flow cell can be calibrated whenever you think that a calibration is required.

Equipment required

To perform the calibration you need test solutions, syringes and accessories for desired cell length:

- UV-900 1 mm Calibr. kit, no. 18-6324-01
- UV-900 2 mm Calibr. kit, no. 18-6324-02
- UV-900 5 mm Calibr. kit, no. 18-6324-04
- UV-900 10 mm Calibr. kit, no. 18-6324-05

To calculate the real cell length use the supplied Excel-file:

- UV-900 Cell Calibr. Excel-file, no. 18-6324-06

Removing an old calibration setting

If the instrument already has a calibrated cell length set that differs from the nominal length, a warning message appears on the UV monitor display at start-up. Another message, displaying the calibrated cell length, also appears. The display toggles between these messages. The display automatically returns to the main operating menu after about 45 seconds, or if pressing **OK**.

Please Check UV Cell!
Press OK/Esc to cont.

Real UV Cell Length
(? , ?? mm, SN ??????)

Set UV Cell Length
(-- , -- mm, SN -----)

Set Calibr. Length
(-- , -- mm) -- : --

- 1 To remove an old calibration value, press **Esc** while the display toggles between the two messages. The **Set UV Cell Length** menu appears. Press **OK**.
- 2 At the **Set Calibr. Length** menu, set the cell length to **0**. Press **OK**.

Preparing the calibration

- 1 Remove any old calibration value by setting the cell length to 0 (see above).
- 2 Unpack the UV Test kit.
- 3 Make sure that the Flow restrictor is connected in the flow path after the UV flow cell.
- 4 Mount the Union Luer female/ 1/16" male, included in the test kit, in the upper inlet of the UV flow cell.

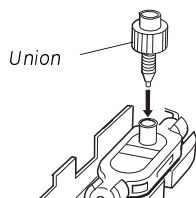

- Open the UV-900 Cell Calibr. Excel-file on the computer.

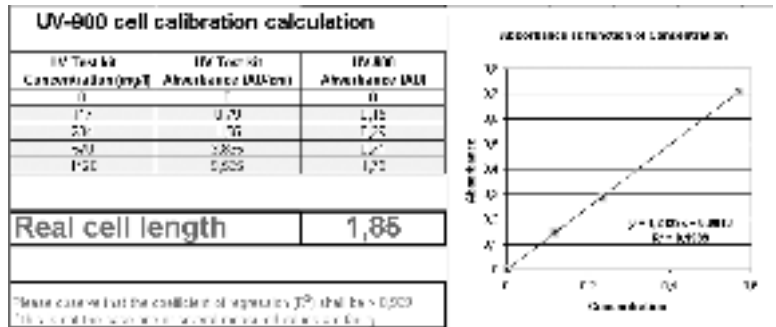

- The solution bottles are marked with the concentration value and the reference absorbance value for each solution.
Enter the concentration of the solutions in increasing order in the column **UV Test kit Concentration (mg/l)**.
Enter the absorbance value in increasing order in the column **UV Test kit Absorbance (AU/cm)**.

Performing the absorbance measurements

For each of the four test solutions, the absorbance will be measured and automatically compared to its reference value.



WARNING! When using hazardous chemicals, take all suitable protective measures, such as wearing protective glasses and gloves resistant to the chemicals used. Follow local regulations and instructions for safe operation and maintenance of the system.



WARNING! Sulfuric acid included in the test solutions is injurious to health. Avoid spillage and use eye protection.

- Switch on the UV lamp, see 3.4 *Setting lamp on/off*.
- Select a main menu on the monitor display that shows wavelength 254 nm.
- Fill one of the supplied syringes with 1.5–2 ml of the 0 AU/cm solution. Make sure that there is no air in the syringe!
- Fit the syringe in the Union Luer connector and inject the solution. Do NOT remove the syringe.
- Wait until the monitored absorbance value is stable.
- Perform an **Autozero** operation. See section 3.7 *Autozero*.

- 7 Remove the syringe.
- 8 Inject the other four test solutions in increasing concentration order. Use a new syringe for each solution.

Note: *Air trapped in the UV cell causes inaccurate measurements. To avoid introducing air into the cell, gently fill the Luer union up to the edge using test solution from the syringe that is next. Then insert the syringe into the Luer union.*

- 9 After each injection, wait for a stable absorbance value and enter the measured values in the column **UV -900 Absorbance (AU)** in the UV-900 Cell Calibr. Excel-file.
- 10 When all absorbance values have been entered, the real cell length is shown next to the **Real cell length** square.

Note: *The regressions coefficient should be larger than 0.999. If not, one or several measured values are faulty.*

Entering the new real length

Set UV Cell Length
(--,--mm, SN-----)

- 1 Select menu **Set UV Cell Length** in the UV monitor. Press **OK**. The **Set Calibr. Length** menu appears. Press **OK**.

Set Calibr. Length
(--,--mm) --.--

- 2 Enter the **Real cell length** value (from the Excel-file) and press **OK**.

Set UV Cell Type
(2 mm)

- 3 The **Set UV Cell Type** menu appears. Check the cell type value.

If the value is correct, turn the selection dial clockwise to go to next menu. If the value has to be changed, press **OK** to change it.

- 4 At the **Set Cell Serial No.** menu press **OK**.

Set Cell Serial No.
(SN -----) -----

- 5 Enter the serial number of the cell (see the label on the flow cell). Press **OK**.

3.12 Changing flow cell

The flow cell can be changed when required, for example from 2 mm to 10 mm when the sensitivity of the measurement must change due to a small amount of sample being applied, or from a 10 mm to 2 mm when a lower sensitivity is desired, due to output signal limitation.

See section 2.3 *Installing the flow cell*.

3.13 Restart after power failure

If the power supply to the instrument is interrupted, the instrument automatically restarts itself and displays the main operating window. All set values are retained in the instrument but the instrument starts with the lamp switched-off.

4 Maintenance



WARNING! Always disconnect the power supply before attempting to replace any item on the system during maintenance.



WARNING! Only spare parts that are approved or supplied by GE Healthcare may be used for maintaining or servicing the system.

4.1 Periodic maintenance

Interval	Action (see procedures below)
Every 3 month	Check the instrument
Every 6 month or more often if required	Clean the flow cell and optical fiber connectors



WARNING! Remove liquid or dirt from the system surface using a cloth and, if necessary, a mild cleaning agent.



WARNING! When using hazardous chemicals, take all suitable protective measures, such as wearing protective glasses and gloves resistant to the chemicals used. Follow local regulations and instructions for safe operation and maintenance of the system.



WARNING! When using hazardous chemicals, make sure that the entire system has been flushed thoroughly with bacteriostatic solution, e.g. NaOH, and distilled water before service and maintenance.

4.2 Cleaning-in-place

Pump a cleaning or sanitizing agent through the flow cell. The standard recommendation is to pump 1 M NaOH at 1 ml/min for 30 minutes and then wash out with buffer.



WARNING! NaOH is injurious to health. Avoid spillage.

4.3 Checking the instrument

4.3.1 Lamp intensity

Check Lamp Intensity
210nm 85% 300nm 95%

- 1 Select menu **Check**, press **OK**.
- 2 Select menu **Check Lamp Intensity**.

If the lamp intensity is < 20%, contact GE Healthcare for lamp replacement or change of internal optical fiber.

4.3.2 Lamp on-time

Check Lamp Run Time
200h

- 1 Select menu **Check**, press **OK**.
- 2 Select menu **Check Lamp Run Time**.

If the lamp ontime is > 4000 hours, contact GE Healthcare for lamp replacement.

4.3.3 Flip time

The flip time is the time the monochromator stepper motor has been in operation.

- 1 Select menu **Check**, press **OK**.
- 2 Select menu **Check Flip Time**.

Check Flip Time
50h

If the flip time is > 2000 hours, contact GE Healthcare for maintenance.

4.3.4 UV flow cell

This menu shows the set path length and the serial number of the UV flow cell.

- 1 Select menu **Check** and press **OK**.
- 2 Select menu **UV Flow Cell**.

UV Flow Cell
(--,-mm, SN -----)

4.4 Cleaning the flow cell and optical fiber connectors

A clean flow cell and optical connectors are essential for ensuring the correct operation of the UV-monitor.

CAUTION! Do not allow solutions containing dissolved salts, proteins or other solid solutes to dry out in the cell. Do not allow particles to enter the flow cell as damage to the flow cell may occur.

4.4.1 Cleaning the flow cell

- 1 Connect a syringe to the inlet of the flow cell and squirt distilled water through the cell in small amounts. Then fill the syringe with a 10% surface active detergent solution like *Decon 90*, *Deconex 11*, *RBS 25* or equivalent, and squirt five times.
- 2 After five squirts, leave the detergent solution in the flow cell for at least 20 minutes.
- 3 Pump the remaining detergent solution through the flow cell.
- 4 Rinse the syringe and flush the cell with distilled water (10 ml).

4.4.2 Cleaning the optical fiber connectors

Wipe with 30% isopropanol on lens paper.

4.4.3 Instrument housing



WARNING! When using hazardous chemicals, make sure that the entire system has been flushed thoroughly with bacteriostatic solution, e.g. NaOH, and distilled water before service and maintenance.

4.5 Cleaning the system

- Wipe the surface regularly with a damp cloth. Do not allow spilt liquid to dry on the instrument.
- Remove dirt from the surface using a cloth and a mild cleaning agent.
- Let the system dry completely before using it.

Wipe the instrument housing regularly with a damp cloth. Let the instrument dry completely before use.



4.6 *Recycling*

This symbol indicates that the waste of electrical and electronic equipment must not be disposed as unsorted municipal waste and must be collected separately. Please contact an authorized representative of the manufacturer for information concerning the decommissioning of equipment

5 Trouble-shooting

5.1 General

Monitor UV-900
V1.06

When contacting GE Healthcare for support, state the program version of the instrument, which is shown for 2 seconds after the self-test, during switch-on, or in the menu **Check Service Mode**, see *page 35*.



WARNING! The instruments must not be opened by the user. They contain high voltage circuits which can give a lethal electric shock.

5.2 Faults and actions

If the suggested actions do not correct the fault, call GE Healthcare.

Fault	Possible cause	Corrective action
No text on the front display	No power to the monitor	Check that the mains cable is connected and the power switch is in ON-position I
Noisy UV-signal, signal drift or instability	The buffer may be impure There may be air in the flow cell	Check if the signal is still noisy with water Check that the flow restrictor gives a back pressure of 0.2 MPa in ÄKTAexplorer, and 3-5 MPa in ÄKTApurifier If there is a lot of air in the water, degas the buffer continuously (we recommend helium sparging) Check the connections of the UV cell optical fibers Clean the UV cell, see section 4.4
Ghost peaks	Air in the eluents Dirt or residues in the flow path from previous runs Residues in the column from previous runs Bad mixing of the eluents	Degas if necessary (we recommend helium sparging) Clean the system in accordance with ÄKTAexplorer or ÄKTApurifier System Manual Clean the column in accordance with the column instructions Check that the mixer is functioning correctly and that the correct chamber volume is being used
Error in external chart recorder	The recorder not properly set up Monitor UV-900 not properly set up	Check the chart recorder in accordance with its manual Test the recorder function by selecting recorder test according to section <i>Check Analogue Out on page 35</i>

5.3 Error messages

If the suggested actions do not correct the fault, call GE Healthcare.

Message	Action
Sample fiber failure	There may be too high absorption in the UV cell. <ol style="list-style-type: none"> 1. Check the liquid. 2. Ensure that there are no air bubbles in the system. 3. Check the connections of the UV cell optical fibers. 4. Clean the UV cell, see section <i>Cleaning the flow cell and optical fiber connectors</i>.
Not calibrated Calibration failed	Recalibrate by switching the instrument off and then back to on, or choose Recalibrate in the Check menu
Change lamp	Call GE Healthcare for Xe-lamp exchange
Mode fiber failure Reference fiber failure Lamp module failure Low light intensity Block filter is defect	Call GE Healthcare
High intensity in Reference fiber	Recalibrate by switching the instrument off and on
High intensity in Sample fiber	<ol style="list-style-type: none"> 1. Disconnect the optical fiber connectors. 2. Recalibrate by switching the instrument off and on.
ERROR Number 10 ERROR Number 16 ERROR key (OK) ERROR key (Esc) ERROR key (OK+Esc) ERROR 100 ERROR 109-113 ERROR 120-121	<ol style="list-style-type: none"> 1. Switch off the instrument. 2. Check all connections. 3. Switch on the instrument.
ERROR 106-108 ERROR 118	<ol style="list-style-type: none"> 1. Switch off the instrument. 2. Check all UniNet connections. 3. Switch on the instrument.

Reference information

A Description

A.1 Instrument

The Monitor UV-900 is a UV-absorption monitor with variable wavelength. The instrument contains no internal user replaceable items.

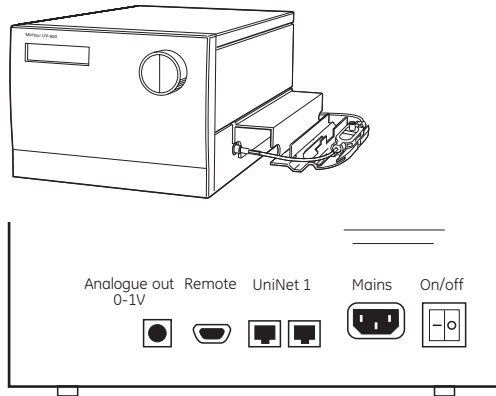

Connector/switch	Function
Analogue out 0-1 V	Recorder output, 3 channels 0-1 V
Remote	Digital signal inputs, lamp on/off, autozero, event mark
UniNet 1	Computer network
Mains	Supply voltage, grounded
On/off	Instrument on/off switch

Connect any auxiliary equipment to the 9-pole D-Sub female REMOTE connector (5 V TTL signals only).

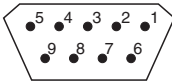

Pin	Signal	Function
		Active status = low or closed terminal to pin 5 (0V)
1	Remote on/off	Active = lamp on, inactive = lamp off
2	Autozero	From inactive to active > 100 ms = Autozero
3	Event mark	From inactive to active > 100 ms = Event mark
4	-	
5	0 V	
6-9	-	

A.2 Flow cell

The optical path length of the flow cell is 2 mm and 10 mm. The flow cell is made of quartz with a titanium housing.

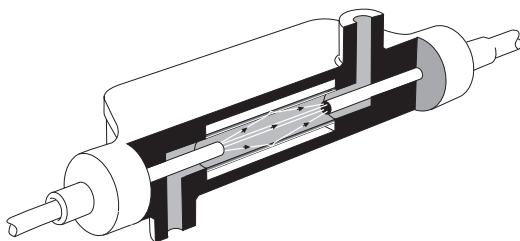

The unique design of the flow cell prevents the formation of distinct interfaces between eluent components with different refractive indices and eliminates the negative influence these would cause. The precision of monitoring is enhanced by the construction of the flow cell, which ensures total reflectance of light. This maintains a high intensity of light to the detector. The long path length combined with a small cell volume increases sensitivity.

A.3 Monitor principle

A Xenon flash lamp gives a high intensity, continuous spectrum throughout the range 160–2000 nm. The light enters a monochromator which includes a condensing system, blocking filter, entrance slit and a concave aberration-corrected holographic grating. Monochromatic light from the grating is directed to an optical fibre. The grating is turned by a stepping motor for wavelength selection between 190–700 nm, in steps of 1 nm. Up to 3 wavelengths can be monitored simultaneously.

For wavelengths between 360–700 nm, a blocking filter is moved into the light path to filter out unwanted light, of a half wavelength from the second order spectrum, before entering the monochromator.

The light from the monochromator to the flow cell and from the cell to the detector electronics is guided by optical fibres which focus its full intensity on the liquid flow path, maximising the sensitivity of the monitoring. Before entering the flow cell, the monochromatic light is split in a beam splitter, with 50% of the light passing through the sample fibre (S) and the flow cell, and 50% being directed through the reference fibre (R). Two photodiodes with identical characteristics monitor the intensities of the measuring and reference beams.

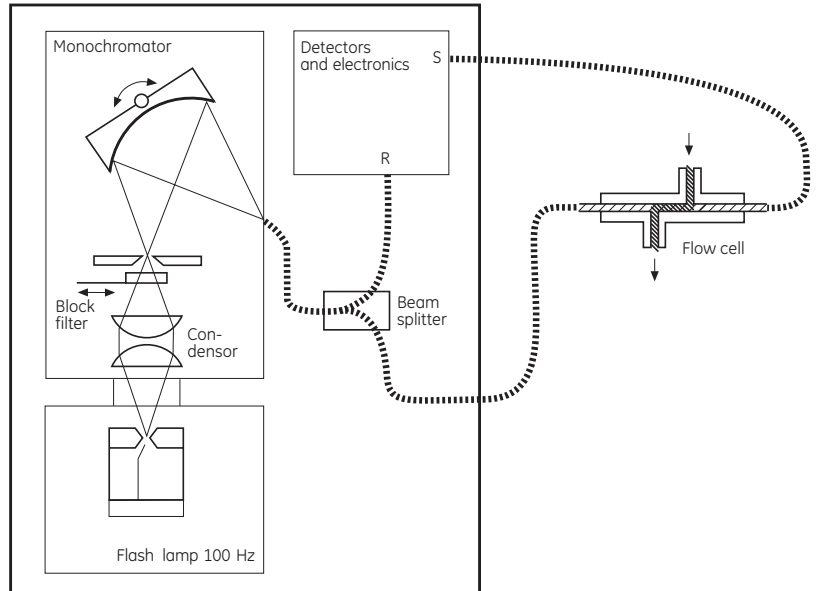

The long path length and small volume of the flow cell ensure very high sensitivities and high signal-to-noise ratios. The detection system is also very stable and because the optical unit is located away from the lamp and electronics, noise and drift caused by temperature variations is avoided.

At calibration the instrument automatically finds 2 persistent lines in the spectrum of Xenon. The wavelengths of these known lines are used to calibrate the stepper motor that turns the grating.

B Menus

B.1 Check menu

Checking autozero level

The instrument internal absorbance value for autozero can be checked to test the consistency in buffers.

Check Autozero	
AZ1 (215)	0.23456 AU

- 1 Select main menu **Check**, press **OK**. The autozero absorbance value for wavelength **1** is shown.

AZ2 (254)	0.23775 AU
AZ3 (280)	0.12326 AU

- 2 Turn the selection dial clockwise to display wavelengths **2** and **3**.

Lamp intensity, Lamp Ontime, Fliptime, UV Flow cell

See *Chapter 4 Maintenance*.

Checking the wavelength

If there is any doubt that the instrument is showing the correct values, the wavelength calibration can be checked.

- 1 Select main menu **Check**, press **OK**.
- 2 Select sub menu **Check Wavelength**, press **OK**. The check starts and after approx. 20 seconds the message **Wavelength OK** or **Wavelength not OK** is shown together with the deviation values. If not OK, recalibration can be selected.

Checking Wavelength
Please wait...

Wavelengths OK
230+0 459+0 542+0 OK

or

Checking Wavelength
Please wait...

Wavelengths not OK
230-4 459+3 542+4 OK

Wavelengths not OK
Recalibrate? OK

If a deviation in wavelength occurs repeatedly when checked, contact Amersham Biosciences.

Recalibrate

If the instrument is left switched on for a long period (> 10 days), it may be necessary to recalibrate it. This calibration is identical to that done when the instrument is switched on.

- 1 Select main menu **Check**, press **OK**.
- 2 Select sub menu **Recalibrate**, press **OK**. The recalibration starts and after approx. 60 seconds the message **Recalibration finished** is shown.

Recalibrating
Please wait...

Recalibration
finished OK

Check Analogue Out

The function of the connected chart recorder can be tested.

- 1 Select main menu **Check**, press **OK**.
- 2 Select sub menu **Check Analogue Out**, press **OK**.
- 3 Start the test by selecting **on**, press **OK**. The test will ramp the signal on each channel up to 1 V and then decrease the signal in 10% steps back to 0 V. The test is run continuously. Compare the diagram of the chart recorder with the figure.
- 4 Stop the test by pressing **OK** or **ESC**.

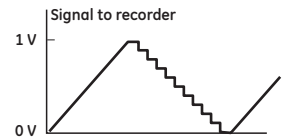

Check Analogue Out
(off) on

Check Service Mode

Service information relevant to the instrument can be checked. Information may not be available in all menus.

- 1 Select main menu **Check**, turn the selection dial clockwise for next display.

Check Service Mode

- 2 Select sub menu **Check Service Mode** by pressing **OK**.

Telephone Service
012345678901

- 3 The service telephone number is displayed. Turn the selection dial clockwise to view the next display.

Contract Number
012345678901

- 4 The service contract number is displayed. Turn the selection dial clockwise to view the next display.

Serial Number
01234567 YM 012345

- 5 The instrument serial number is displayed. Turn the selection dial clockwise to view the next display.

Monitor UV-900
V1.06

- 6 The instrument name and software version are displayed. Turn the selection dial clockwise to view the next display.

Date of Maintenance
?

- 7 The date of the last service is displayed. Turn the selection dial clockwise to view the next display.

Buzzer Test.

- 8 Press **OK** to test the instrument buzzer.

Press **Esc** to return to the **Check Service Mode** menu.

B.2 Setup menu

Setup language

Sets the language used in the display.

Setup Language
(GB) GB D F E I

- 1 Select main menu **Setup**, press **OK**.
- 2 Select sub menu **Setup Language**, press **OK**.
- 3 Select the desired language.
GB = British English
D = German
F = French
E = Spanish
I = Italian

Setup unit number

The unit number is the identification the UV monitor has on the UniNet-bus. It should correspond to the number set in UNICORN for the UV monitor. The number should be set to **0** if one UV monitor is used. If more than one UV monitor is used, they must all have different identification numbers.

Setup Unit Number
(0)

- 1 Select main menu **Setup**, press **OK**.
- 2 Select sub menu **Setup Unit Number**, press **OK**.
- 3 Select unit number (**0-25**).

Setup display angle

The display angle can be set to compensate for different viewing heights.

Setup Display Angle
(->|) ->\ ->| ->/

- 1 Select main menu **Setup**, press **OK**.
- 2 Select sub menu **Set Display Angle**, press **OK**.
- 3 Select viewing angle (->\ Up, ->| Mid or ->/ Down).

B.3 Setting and using the alarm timer

You can set the alarm function to either a fixed alarm time or using a count-down timer. The UV monitor can be started or stopped automatically, or an alarm can sound, at the set time. It is not possible to set both an alarm time and a count-down timer. Current values are shown in parentheses.

Alarm/Timer 12:30:52

- 1 Select main menu **Alarm/Timer**, press **OK**.

Alarm/ Timer Action
(Bzz) Buzzer Run End

- 2 Set the action to take place. Press **OK** to select action. **Buzzer** will generate an audible alarm for 15 s and a message. **Run** will start the pump at the set flow rate, **End** will stop the pump, each generating one beep and a message.

Set Alarm 12:32:22
(0) 00.00.00

- 3 Use the sub menu **Set Alarm** if you want to set an alarm at a fixed time. Press **OK** to enter the time value in the form **HH.MM.SS**, pressing the **OK** button after entering each time unit.

Set Timer
(0) 00.00.00

- 4 If you want to set a count-down timer, turn the dial to select sub menu **Set Timer**. Press **OK** to enter the countdown value in the form **HH.MM.SS**, pressing the **OK** button after entering each time unit.

Alarm/Timer 12:30:52
(Bzz 12:33:00)

- 5 Press **ESC** button to return to the **Alarm/Timer** menu which now shows the set alarm time or count-down time as **BzzHH:MM:SS**.

Bzz12:41:29 12:41:49
!! Alarm time !!

- 6 When the alarm time is due or the count-down timer reaches 00:00:00, an alert display is shown and the instrument beeps, until the **OK** button is pressed.

Set Clock
00:32:22 (00:36:53)

The alarm timer is based on the internal instrument clock which can be set in the **Set Clock** menu placed after the **Alarm/Timer** menu. The clock will be reset when power is turned **OFF**.

Alarm/Timer off?
(Bzz 05:33:00)

An already set alarm/timer function can be reset by pressing **OK** in the menu **Alarm/Timer off?**

B.4 Service displays

Enter Access Code!

The instrument has service displays for use by authorised service personnel. If the service display **Enter Access Code:** is accidentally selected, press the **ESC** button to exit to the normal operation display.

B.5 Menu overview

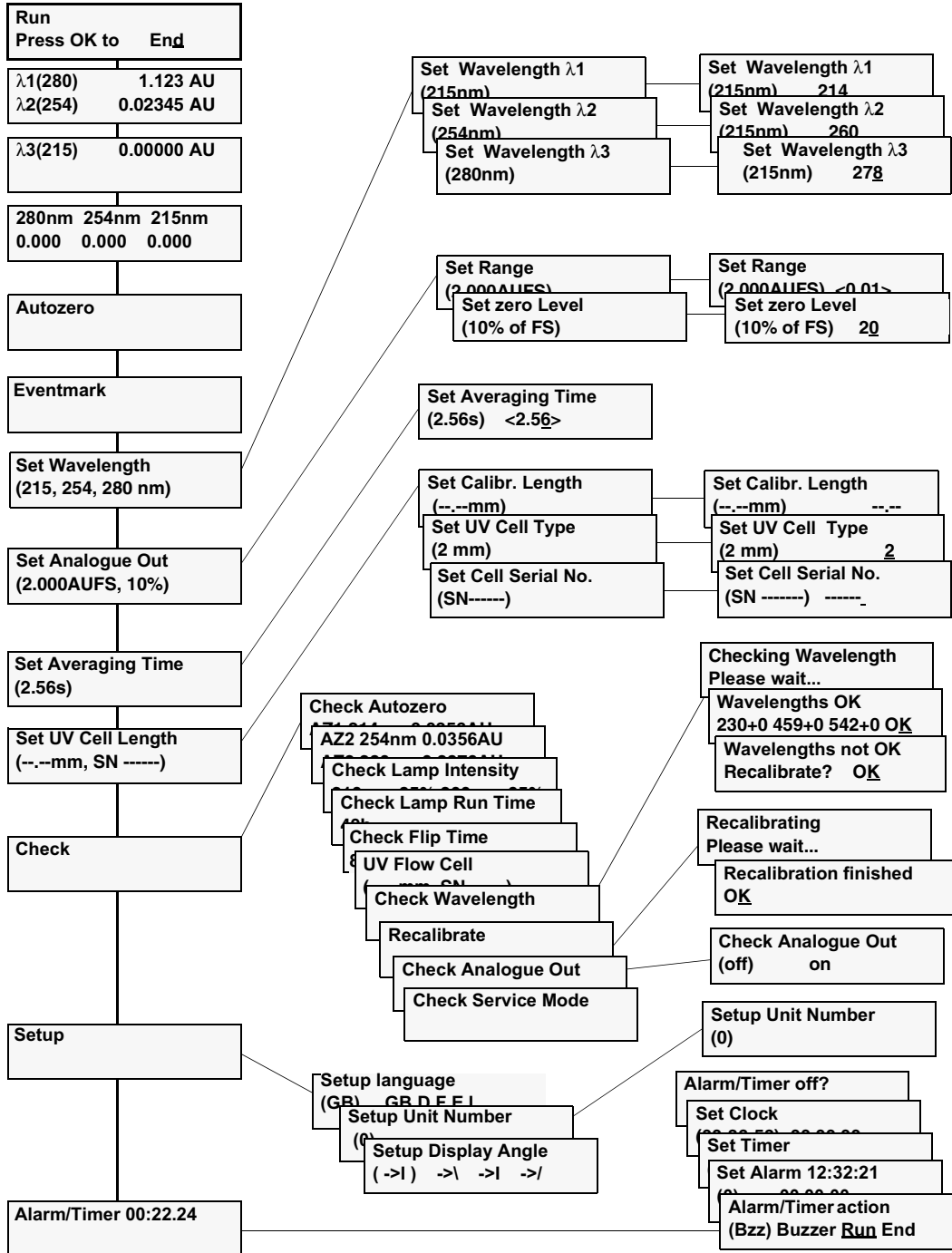

C Technical specifications

Operating data

<i>Wavelength range</i>	190–700 nm in steps of 1 nm, 3 wavelengths simultaneously
<i>Bandwidth</i>	4 nm
<i>Wavelength accuracy</i>	±2 nm
<i>Wavelength reproducibility</i>	±0.01 nm
<i>Wavelength switch time</i>	< 500 ms (one cycle from 214 nm to 254 nm and back to 214 nm)
<i>Linearity</i>	< 2% deviation up to 2 AU at 260 nm with Uracil at pH 2
<i>Noise (specified for 10 mm flow cell)^{1, 2}</i>	
<i>Single wavelength</i>	
<i>short term (0.5–1 min)</i>	< 6×10 ⁻⁵ AU at 230 nm
<i>long term (1–10 min)</i>	< 6×10 ⁻⁵ AU at 230 nm
<i>Dual wavelengths</i>	
<i>short term (0.5–1 min)</i>	< 2×10 ⁻⁴ AU at 230 and 254 nm
<i>long term (1–10 min)</i>	< 2×10 ⁻⁴ AU at 230 and 254 nm
<i>Drift²</i>	< 2×10 ⁻⁴ AU/h at 254 nm
<i>Environment</i>	+4 to +40 °C 20–95% relative humidity 84–106 kPa (840–1060 mbar) atmospheric pressure

¹ Measured with water at 1 ml/min, time constant 1 s.

² Typical values at room temperature after warm-up.

Flow cell

<i>Max. flow rate</i>	100 ml/min
<i>Max. pressure</i>	2 MPa (20 bar, 290 psi)
<i>Backpressure</i>	Max. 0.5 bar at 2 ml/min with water at 25 °C
<i>Liquid temperature range</i>	+4 to +40 °C
<i>Optical path length</i>	
<i>2 mm cell</i>	2 mm
<i>10 mm cell</i>	10 mm
<i>Cell volume</i>	
<i>2 mm cell</i>	2 µl
<i>10 mm cell</i>	8 µl
<i>Degree of protection</i>	IP 21
<i>Wetted materials</i>	PTFE (polytetrafluoroethylene) PEEK (polyetheretherketone) Titanium (palladium alloy) Quartz (synthetic fused silica)
<i>pH stability range</i>	1–13, 1–14 (<1 days exposure)

<i>Chemical resistance</i>	The wetted parts are resistant to organic solvents and salt buffers commonly used in chromatography of biomolecules, except 100% Ethyl acetate, 100% Hexane, and 100% Tetrahydrofuran (THF)
<i>Tubing connections</i>	UNF 10-32 "fingertights" for capillary tubing with 1/16" outer diameter
Physical data	
<i>Light source</i>	Xenon flash lamp
<i>Lamp lifetime</i>	> 4000 hours
<i>Control</i>	Stand alone or from a computer running UNICORN 3.21 or higher through UniNet-1 connection
<i>Power consumption</i>	65 VA
<i>Power requirement</i>	100–240 V AC, 50–60 Hz
<i>Analogue output</i>	3 signals, 0–1 V full scale, overrange function
<i>Digital inputs</i>	5 V, 1 mA current sinking, lamp on/off, autozero, event mark
<i>Display</i>	2 rows with 20 characters each
<i>Dimensions (H xW xD)</i>	200 x 260 x 370 mm
<i>Weight</i>	8.5 kg
<i>Degree of protection</i>	IP 20
<i>Compliance with standards</i>	The declaration of conformity is valid for the instrument only if it is: <ul style="list-style-type: none"> • used in laboratory locations • used in the same state as it was delivered from GE Healthcare except for alterations described in the User Manual • connected to other CE labelled GE Healthcare modules or other products as recommended.
<i>Safety Standards</i>	This product meets the requirement of the Low Voltage Directive (LVD) 73/23/EEC through the following harmonized standards: <ul style="list-style-type: none"> • EN61010-1 • IEC 61010-1 • CAN/CSA-C22.2 No. 61010-1 • UL61010-1

EMC standards

This device meets the requirements of the EMC Directive 89/336/EEC through the following harmonized standards:

- EN 61326 (emission and immunity)
- EN 55011, GR 2, Class A (emission)
- This device complies with part 15 of the FCC rules (emission). Operation is subject to the following two conditions:
 - 1 This device may not cause harmful interference.
 - 2 This device must accept any interference received, including interference that may cause undesired operation.

D Accessories and spare parts

Item	Quantity per pack	Code no.
Monitor UV-900 complete but without flow cells	1	18-1108-35
Flow cell UV-900/2 (2 mm)	1	18-1111-10
Flow cell UV-900/10 (10 mm)	1	18-1111-11
Signal cable	1	18-1110-64
Fibre detachment tool	1	18-1111-16
Teflon tubing, i.d. 1/8", o.d. 3/16"	3 m	18-1112-47
Tubing connector for 3/16" o.d. tubing	10	18-1112-49
Ferrule for 3/16" tubing	10	18-1112-48
Stop plug, 5/16"	5	18-1112-50
Stop plug, 1/16"	5	18-1112-52
Union Luer female/1/16" male	2	18-1112-51
Union 1/16" female/M6 male	6	18-1112-57
Union M6 female/1/16" male	8	18-1112-58
Union 1/16" male/ 1/16" male, i.d. 0.25 mm	2	18-1120-92
Union 1/16" male/ 1/16" male, i.d. 0.50 mm	2	18-1120-93
PEEK tubing, i.d. 0.15 mm, o.d. 1/16"	2 m	18-1156-59
PEEK tubing, i.d. 0.25 mm, o.d. 1/16"	2 m	18-1120-95
PEEK tubing, i.d. 0.50 mm, o.d. 1/16"	2 m	18-1113-68
PEEK tubing, i.d. 0.75 mm, o.d. 1/16"	2 m	18-1112-53
PEEK tubing, i.d. 1.0 mm, o.d. 1/16"	2 m	18-1115-83
Tefzel tubing, i.d. 0.25 mm, o.d. 1/16"	2 m	18-1121-36
Teflon tubing, i.d. 0.75 mm, o.d. 1/16"	2 m	18-1112-54
Fingertight connector 1/16"	10	18-1112-55
UV-900 1 mm Calibr. kit	1	18-6324-01
UV-900 2 mm Calibr. kit	1	18-6324-02
UV-900 5 mm Calibr. kit	1	18-6324-04
UV-900 10 mm Calibr. kit	1	18-6324-05
UV-900 Cell calibr. Excel-file	1	18-6324-06

Short instructions

The following short instructions are intended as a guide for users who are fully familiar with the safety precautions and operating instructions described in this manual. The instructions assume that the unit is installed according to the installation instructions.

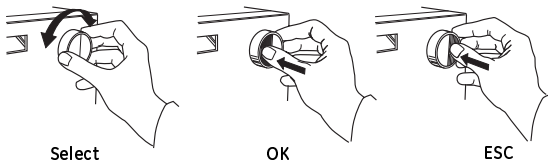
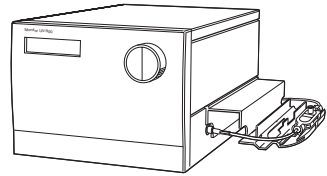

- 1 **Switch on the module** with the mains switch on the rear panel.
- 2 **Switch on the UV-lamp** by selecting **Run**.
- 3 **Select wavelength** for one, two or three wavelengths.
- 4 **Autozero** the module by pressing **OK**.
- 5 **The main operating menu** (RUN-menu) is shown.

Calibrating Please wait...

End Press OK to Run

Set Wavelength (215, 254, 280 nm)
--

Set Wavelength λ1 (215nm)

Set Wavelength λ2 (254nm)

Set Wavelength λ3 (280nm)

Autozero

λ 1(215)	1.123 AU
λ 2(254)	0.02345 AU

λ 3(280)	1.123 AU
------------------	----------

www.chromatography.amershambiosciences.com

GE Healthcare Bio-Sciences AB
Björkgatan 30
751 84 Uppsala
Sweden

ÄKTA, ÄKTA design, UNICORN and DropDesign are trademarks of GE Healthcare Ltd, a General Electric Company. GE, imagination at work and GE monogram are trademarks of General Electric Company.

All goods and services are sold subject to the terms and conditions of sale of the company within GE Healthcare which supplies them. GE Healthcare reserves the right, subject to any regulatory and contractual approval, if required, to make changes in specifications and features shown herein, or discontinue the product described at any time without notice or obligation. Contact your local GE Healthcare representative for the most current information.

© 2005 General Electric Company – All rights reserved.

GE Healthcare AB
Björkgatan 30, 751 84 Uppsala, Sweden

GE Healthcare AB
Munzinger Strasse 9, D-79111 Freiburg, Germany

GE Healthcare AB
Amersham Place, Little Chalfont, Buckinghamshire, HP7 9NA, UK

GE Healthcare AB
800 Centennial Avenue, P.O. Box 1327, Piscataway, NJ 08855-1327, USA

GE Healthcare AB
Sanken Bldg. 3-25-1, Huakunincho, Shinjuku-ku, Tokyo 169-0073, Japan

Asia Pacific Tel: +852 2811 8693 Fax: +852 2811 5251 • Australasia Tel: +61 2 9899 0999 Fax: +61 2 9899 7511 • Austria Tel: 01/57606-1619 Fax: 01/57606-1627 • Belgium Tel: 0800 73 888 Fax: 03 272 1637 • Canada Tel: 800 463 5800 Fax: 800 567 1008 • Central, East, & South East Europe Tel: +43 1 982 3826 Fax: +43 1 985 8327 • Denmark Tel: 45 16 2400 Fax: 45 16 2424 • Finland & Baltics Tel: +358-109-512 39 40 Fax: +358 109 512 39 439 • France Tel: 01 69 35 67 00 Fax: 01 69 41 96 77 • Germany Tel: 0761/4903-490 Fax: 0761/4903-405 • Italy Tel: 02 27322 1 Fax: 02 27302 212 • Japan Tel: +81 3 5331 9336 Fax: +81 3 5331 9370 • Latin America Tel: +55 11 3933 7300 Fax: +55 11 3933 7304 • Middle East & Africa Tel: +30 210 9600 687 Fax: +30 210 9600 693 • Netherlands Tel: 0165 580 410 Fax: 0165 580 401 • Norway Tel: 815 65 555 Fax: 815 65 666 • Portugal Tel: 21 417 7035 Fax: 21 417 3184 • Russia & other C.I.S. & N.I.S. Tel: +7 10951 232 0250, 956 1137 Fax: +7 10951230 6377 • South East Asia Tel: 60 3 8024 2080 Fax: 60 3 8024 2090 • Spain Tel: 93 594 49 50 Fax: 93 594 49 55 • Sweden Tel: 018 612 1900 Fax: 018 612 1910 • Switzerland Tel: 0848 8028 12 Fax: 0848 8028 13 • UK Tel: 0800 616928 Fax: 0800 616927 • USA Tel: 800 526 3593 Fax: 877 295 8102



imagination at work