



Digital Vortex Mixer

88882009 & 88882010

In the United States:

For customer service, call 1-800-766-7000
To fax an order, use 1-800-926-1166
To order online: thermofisher.com

In Canada:

For customer service, call 1-800-234-7437
To fax an order, use 1-800-463-2996
To order online: thermofisher.ca

Find out more at thermofisher.com

ThermoFisher
SCIENTIFIC

Operating Manual

Revision A .09 26 2019

ThermoFisher
SCIENTIFIC

Contents

Section 1 Important Information	1
Disposing of Product	2
<hr/>	
Section 2 Introduction	3
Feature	3
Packing List	4
Connections	4
Structure Diagram	4
<hr/>	
Section 3 Overview	5
Specifications	5
Environmental Conditions	5
<hr/>	
Section 4 Operation	6
Control Panel	6
Settings	7
Installation of Accessories	9
<hr/>	
Section 5 Safety Tips	11
<hr/>	
Section 6 Cleaning and Maintenance	12
<hr/>	
Section 7 Troubleshooting	13
<hr/>	
Section 8 Optional Accessories	14
<hr/>	
Section 9 Warranty	16
<hr/>	

Section 1 Important Information

Ignoring the following warnings could cause serious injuries or even fatal accidents.

Check the voltage, phase and capacity of power supply on the ID plate before installation. Connect properly.

Power supply must be properly grounded. Abnormal grounded connection causes serious damage. Grounded connection must not be on the water pipe and gas pipe.

Use provided power cord. Power cord: Wall outlet with grounded terminal power cord 250V 10A.

Do not install the product in a place that gas could leak. Do not use in a place that has industrial oil smoke or metallic dust. It causes fire or electric shock. Do not use the machine near to places where explosion could happen due to organic evaporating gases.

Explosive materials: acid, ester, nitro compound.

Inflammable materials: salt peroxides, inorganic peroxide, salt acids.

Check equipment for permissible environmental conditions when using inside of Temperature and Humidity Chamber or Incubator. It can be the cause of fire or trouble by stirrer electricity, electronic, and damage of motor.

Mixer's permissible environmental condition. Temperature 5°C to 40°C, Maximum relative humidity 85%.

Unplug if there is a strange sound, smell and/or smoke from the product. Stop

operating and request the service.

Keep out of the direct sunlight. It may influence product life and proper operation.

Do not use the machine at places where moisture is high and flooding can happen.

Do not assemble, repair, modify on your own. The product may not work well and electric shock is possible with changes in the efficiency of the product. Also this will void the warranty.

Indicates a hazardous situation which, if not avoided, may result in minor or moderate injury.

Do not put heavy things on the power cord. Do not put the machine on the cord. It may take off the wire coating and cause electric shock or fire.

Do not touch it with wet hands and place the main plug correctly. It could cause the electric shock or injuries.

Installing power outlet near instrument may be convenient

Do not install the Vortex Mixer near machinery generating high frequency noise. Avoid installation close to high frequency- welding machine, sewing machine, or mass SCR controller.

Do not inject any liquid and inflammable things inside of product.

Do not pour water or put liquid on the top of the product when cleaning. Disconnect the main power immediately and request the service if water may be in the product.

Do not let the product take any strong shock or vibration. It could cause abnormal operation or trouble. It may deteriorate the ability of the product operation and not obtain correct results.

Do not sprinkle insecticide or flammable spray on the product. Use smooth cloths. Cleaning with solvent can cause fire and deformity.

Power off while product cleaning. It may cause electric shock or fire.

Do not drop or allow the machine to fall. It will cause wrong operation and malfunction.

Disposing of Product

Dispose the unit with separating plastic mold, and motor.

Section 2 Introduction





Welcome to use Thermo Scientific Vortex Mixers. Vortex mixers are used in biomedical engineering, physical and chemical analysis, environmental monitoring, food, hygiene, petrochemical, metallurgy and other fields, for cell culture, sample tissue, chemical reagents, bacteria liquid and other substances mixed. It is suitable for test tubes, centrifugal tubes, color tubes, enzyme plates, deep hole plates, PCR plates and other containers.

2.1 Feature

It can be easily switched between touch and continuous modes and the corresponding light is on when working normally.

- ◆ It has speed adjustment display function.
- ◆ It has timing and LED time display function for up to 99 minutes, which can be freely switched minutes or seconds.
- ◆ It has a high sensitivity touch switch.
- ◆ It uses keys and a simple control panel and provides precise speed control.
- ◆ The combined buttons can quickly set the speed to 200rpm, 1500rpm, 3000rpm.
- ◆ A variety of accessories can be selected to maximize the needs of customers.
- ◆ It uses brushless DC motor, with accurate speed control, stability, safe and reliable features.
- ◆ It has a power recovery function.

2.2 Packing List

Description	Catalog Number		Figure
Digital Vortex Mixer	88882009	88882010	
Rubber Platform	1	1	
Power Adapter 120V	1	N/A	
Multi-Power Adapter 220V	N/A	1	

2.3 Connections

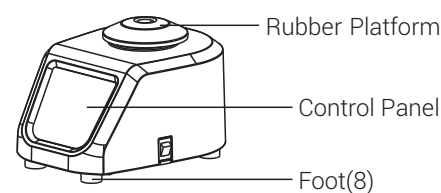

2.4 Structure Diagram

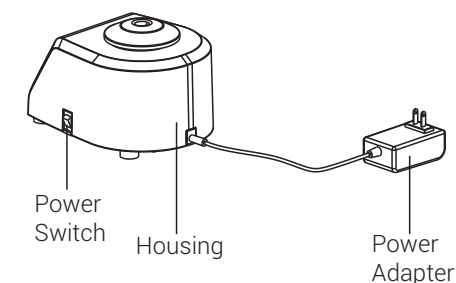

Section 3 Overview

3.1 Specifications

Rotation Speed	Speed Range.....	200 to 3000rpm
	Speed Accuracy.....	±5%
	Orbit Diameter.....	∅ 4mm
	Operating Mode.....	Touch /Continuous
Load	Maximum Load.....	0.5kg @ 800rpm
	Timing Range.....	0, 1sec.~99min.
Time	Timing Range.....	0, 1sec.~99min.
	Overall Dimensions.....	205×151×131mm
Size	Platform Diameter.....	∅ 76mm
	Net Weight.....	6.5Kg
Weight	Requirement.....	AC100-240V, 50/60Hz, 6W
	Certification.....	RoHS, WEEE, cCSAus, CE Mark
Power Supply	IP Class.....	Ip32
	Others	

3.2 Environmental Conditions

Application Environmental Conditions: indoor use

Temperature.....	5 to 40°C
Altitude.....	≤2,000 m
Humidity.....	20% to 85%

Storage Environmental Conditions

Temperature.....	0 to 60°C
Altitude.....	≤2,000 m
Humidity.....	20% to 90%, non-condensing

Section 4 Operation

This chapter covers the control panel and its operation.

4.1 Control Panel

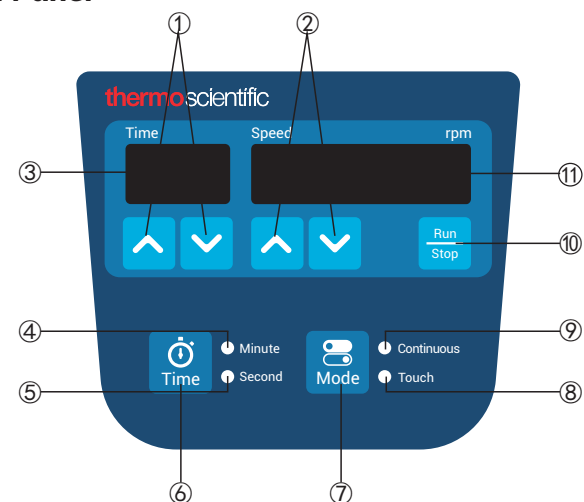

1. Time setting buttons: UP/DOWN arrow buttons are used to increase/decrease the set time of the instrument.
2. Speed setting buttons: UP/DOWN arrow buttons are used to increase/decrease the set speed of the instrument.
3. Time display window: The window displays cumulative time (the set time is "0") or remaining time (the set time is not "0").
4. Minute indicator: When in minute, light up.
5. Second indicator: When in second, light up.
6. Time unit select button: To switch time unit between minute and second.
7. Mode button: To switch running mode between "Touch" and "Continuous".
8. Touch Mode indicator: When in Touch Mode, light up.
9. Continuous Mode indicator: When in Continuous Mode, light up.
10. Run/Stop button: Run or stop the instrument.
11. Speed display window: The window displays set speed (when the instrument is in standby) or current speed (when the instrument is running).

4.2 Settings

Please confirm the environmental condition and the power voltage first, and then, connect the mixer power cord to the power outlet.

Switch On

Press the power switch to position "I" and the display windows are shown as below:

0 0

Time display window

0 2 0 0

Speed display window

The corresponding indicator for the time unit and running mode is on.

Mode Settings

In standby, press "Mode" button to switch "Touch" mode or "Continuous" mode. In "Touch" mode, the instrument starts running automatically when the vessel presses on the Rubber Platform or Flat Bottom vessel Platform, and automatically stops when the vessel leaves the platform. In "Continuous" mode, press "Run/Stop" button, the instrument with tray, platform or tube holder starts running continuously, and press "Run/Stop" button again, the instrument stops running.

Speed setting

In standby, press "▲" or "▼" button below the Speed display windows to set the target speed, for example:

1 6 0 0

In this case, the set speed is 1600rpm. Press "Run/Stop" button, the instrument will slowly accelerate to 1600rpm, and the Speed display windows show the actual speed while the instrument remains in rotation.

In running mode, press "▲" or "▼" button to increase or decrease the speed value. Release the button when the speed shown on the Speed display window reaches the set value. The speed setting is finished after the number shown on the Speed display windows flashed three times.

Note: Press "▲" or "▼" button for a longer time to accelerate the setting.

Quick Speed Setting

The instrument can quickly set speed to 1500rpm, 3000rpm and 200rpm by combination buttons.

In standby, press "▲" and "▼" button at the same time under the Speed display windows over 3s, the instrument speed will be set to 1500rpm, over 6s, the instrument speed will be set to 3000rpm, over 9s, the instrument speed will be set to 200rpm.

Time Unit Setting (Continuous mode)

In standby, press "Time" button to select time unit "Second" or "Minute", the corresponding unit indicator light will be on. Time range is 0 to 99s for "Second", and 0 to 99 minutes for "Minute".

Timer Setting

1. Continuous mode

Timer: In standby, press "▲" or "▼" button below the Time display window to set the time to "0", and then press the "Run/Stop" button, the instrument runs at the set speed, and the running time starts counting. Press "Run/Stop" button again, the instrument stops running.

Down counting: In standby, press "▲" or "▼" button below the Time display window to set a target time (not "0"), and then press "Run/Stop" button, the instrument runs at the set speed, and the running time counts down. When the countdown time ends, the instrument stops running, the display windows flash three times, while the buzzer calls three times, the display windows show the set time and speed.

2. Touch mode

Timer: In standby, set the time to "0", put the vessel onto the Rubber Platform or Flat Bottom Vessel Platform and press to run, the instrument runs at the set speed, and the running time starts counting. When stop pressing the platform, the instrument stop running. The Time display windows flash 5s. Within 5s, put the vessels back and press onto the platform, the timer continuously counts from last operation. After 5s, the timer will be cleared and back to 0.

Down counting: In standby, set as a

target time (not "0"), put the vessel onto the Rubber Platform or Flat Bottom Vessel Platform and press, the instrument runs at the set speed, and the Time display windows show to counts down. When stop pressing the platform, the instrument stops and the Time display windows flash. Within 5s, put the vessels back and press onto the platform, the timer continuously counts down from last operation. After 5s, the timer will be cleared and back to set time. When the countdown time ends, the instrument stops running, the Time display windows flash three times, while the buzzer calls three times, timer display as 00. When stops vessel pressing, the Time display windows show the set time.

Power Recovery

Continuous Mode: If the power is cut off suddenly while the instrument is in operation, the instrument will resume the parameters set before the power is cut off, but the instrument will not continue to run.

Touch Mode: The power is cut off when the instrument is working. If the power is on again, the instrument will resume the parameters set before the power is off, put the vessel onto the Rubber Platform or Flat Bottom Vessel Platform and press to run.

Finish Operation

After use, please press power switch to turn off the power. Unplug the instrument and store it according to the storage guide.

4.3 Installation of Accessories

Installation of Rubber Platform

1. Place the Rubber Platform on the base tray .
2. Press evenly along the perimeter of the Rubber Platform so that the Rubber Platform is stuck on the base tray.

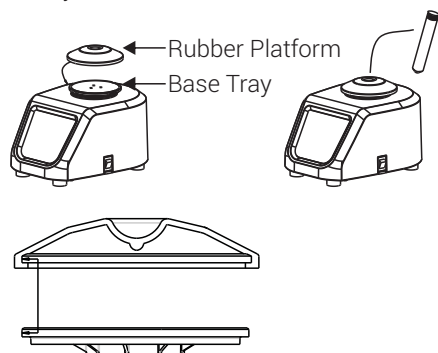

Installation of Flat Bottom Vessel Platform

1. Place the Flat Bottom Vessel Platform on the top of the base tray and align the inner bump of the Flat Bottom Vessel Platform to the groove on the base tray.
2. Press evenly along the perimeter of the Flat Bottom Vessel Platform so that the Flat Bottom Vessel Platform is stuck on the base tray.

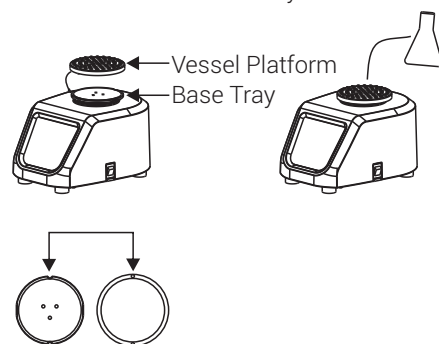

Installation of Microplate Tray

- Microplate Tray are suitable for "continuous" mode and samples are mixed with enzyme ELISA PLATE.
1. Parallel place the Microplate Tray on the top of the base tray.
 2. Gently press both sides of the Microplate Tray to snap it onto the base tray, and please make sure it tighten.

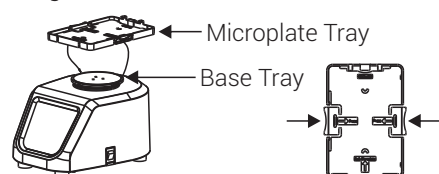

Installation of Tube Holder

Tube Holder are suitable for "Continuous" mode to mixing samples by test tubes.

1. Parallel place the Tube Holder on the top of the base tray.
2. Gently press both sides of the Tube Holder to snap it onto the base tray, and please make sure it tighten.
3. Install the corresponding EVA sponge pad on the Tube Holder, after inserting the test tube, it can start to run.

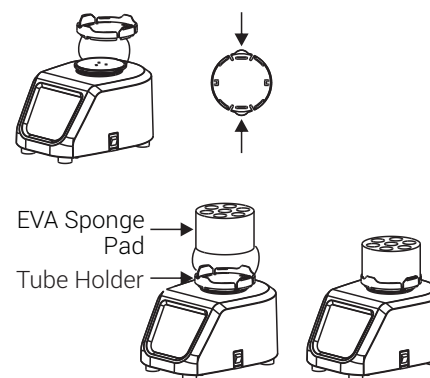

Section 5 Safety Tips

Please read the manual carefully and follow the following safety guidelines before operating this instrument.

1. Please keep this manual for reference for any time.
2. Professionals are required to operate the instrument.
3. The instrument can only be used the original power adapter.
4. When operating the instrument, the operator must choose to wear appropriate clothing to avoid toxic and harmful solvents produced as follows:
 - ◆Harmful liquids splashed
 - ◆The harmful solids ejected
 - ◆Body, hair, clothing is rolled or corroded
5. If the instrument becomes abnormal or higher vibration in use, please immediately reduce the speed accordingly or immediately stop the instrument.
6. Ensure that the accessories and containers are installed correctly.
7. Please check the instrument and accessories are in good condition before each operation.
8. For a single test tube mixing, please put test tube in the middle hole of the rubber platform. For multi-test tube mixing, please always place the test tubes in the center and symmetrically.
9. Be careful of the risks that may arise.
 - ◆Flammable substances
 - ◆Fragile substances
10. Unplug the power before installing the accessories.
11. Carefully handle the instrument to avoid any collision or impact.

Section 6 Cleaning and Maintenance

Cleaning

In order to ensure the safe use of the instrument, please follow the manufacturer's recommendations for cleaning when cleaning the instrument.

- Unplug the power first when cleaning.
- Wipe the instrument with a damp, soft cloth or non-corrosive cleaning agent (ph 8).
- Direct spray instruments are prohibited.
- Make sure that the instrument is completely dry before operating it.
- Please wear gloves when cleaning.

Warning: Avoid dripping detergent or water into the inside of the instrument during cleaning.

Clean Spill

If accidental spillage of liquids caused by mishandling or contained breakage occurs on the surface of the instrument, please shut down the instrument and clean up the liquid immediately. If the liquid has already spilled into the unit, cut off the power supply first and immediately clean up the liquid at the surface of the instrument. Place the instrument in a ventilated and dry environment for 24 hours before reuse. If the instrument is not functioning after drying for 24 hours, please contact the manufacturer.

Warning: Disassembling/Assembling without a qualified professional's guidance may cause malfunctioning of the instrument.

Maintenance

Clean and make sure that there are no harmful residues in the instrument before delivery..









Section 7 Troubleshooting

Please refer to the following table to troubleshoot if any malfunction occurs.

If the problem still exists, contact your local sales representative.

Error	Cause	Solution
Not working properly	Power disconnected	Connect the power
	Power switch off	Switch on power
Loud noise Vibration large Abnormal sound	The instrument is not stable	Place the instrument on a horizontal, rugged platform
	The sample in the test tube is imbalance	Fill an equivalent amount of sample in the test tube
	Contact with other objects of the instrument's case	Remove the objects contacted

Section 8 Optional Accessories

Description	Cat. No.	Touch	Continuous	Speed Range	Dimensions	Figure
Rubber Platform	88882120	✓	✓	200~3000rpm	φ 82×16.5mm	
Flat Bottom Vessel Platform	88882121	✓	✓	200~3000rpm	φ 80×9mm	
Microplate Tray	88882122	-	✓	200~1200rpm	136×97×11.5mm	
10mm dia x19 Tube Holder	88882123	-	✓	200~2000rpm	φ 100×54mm	
12mm dia x 13 Tube Holder	88882124	-	✓	200~1800rpm	φ 100×54mm	
15mm dia x 12 Tube Holder	88882125	-	✓	200~1000rpm	φ 100×68mm	
20mm dia x 7 Tube Holder	88882126	-	✓	200~1000rpm	φ 100×68mm	
26mm dia x 4Tube Holder	88882127	-	✓	200~900rpm	φ 100×68mm	

Note:

- (1). When mixing by ELISA PLATE, the capacity of the ELISA PLATE shall not exceed 1/2 of the maximum capacity. Otherwise, there may be liquid splash.
- (2). The Recommended speed values in the table are for reference only. Change the speed value according to the actual operation of the instrument.

Warning:

When replacing accessories, the instrument must be in standby mode or turn off the power.

Section 9 Warranty

**THERMO FISHER SCIENTIFIC
STANDARD PRODUCT WARRANTY**

The Warranty Period starts two weeks from the date your equipment is shipped from our facility. This allows for shipping time so the warranty will go into effect at approximately the same time your equipment is delivered. The warranty protection extends to any subsequent owner during the first year warranty period.

During the first two (2) years, component parts proven to be non-conforming in materials or workmanship will be repaired or replaced at Thermo's expense, labor included. Installation and calibration are not covered by this warranty agreement. The Technical Services Department must be contacted for warranty determination and direction prior to performance of any repairs. Expendable items, glass, filters and gaskets are excluded from this warranty.

Replacement or repair of components parts or equipment under this warranty shall not extend the warranty to either the equipment or to the component part beyond the original warranty period. The Technical Services Department must give prior approval for return of any components or equipment. At Thermo's option, all non-conforming parts must be returned to Thermo Fisher Scientific postage paid and replacement parts are shipped FOB destination.

THIS WARRANTY IS EXCLUSIVE AND IN LIEU OF ALL OTHER WARRANTIES, WHETHER WRITTEN, ORAL OR IMPLIED. NO WARRANTIES OF MERCHANTABILITY OR FITNESS FOR A PARTICULAR PURPOSE SHALL APPLY. Thermo shall not be liable for any indirect or consequential damages including, without limitation, damages relating to lost profits or loss of products.

Your local Thermo Sales Office is ready to help with comprehensive site preparation information before your equipment arrives. Printed instruction manuals carefully detail equipment installation, operation and preventive maintenance.

If equipment service is required, please call your Technical Services Department at 1-866-984-3766, option number 2. We're ready to answer your questions on equipment warranty, operation, maintenance, service and special application. Outside the USA, please contact local Thermo Technical Services Department or local distributor for warranty information.