

INSTRUCTION MANUAL



Standard 1000RS Rocking Shaker
Advanced 1000RS Rocking Shaker
Advanced 1000WS Waving Shaker



TABLE OF CONTENTS

Package Contents	1
Warranty	1
Installation	2
Maintenance & Servicing	2
Environmental Conditions	2
Equipment Disposal	2
Safety Instructions	3
Standards & Regulations	3
Standard 1000RS Rocking Shaker Specifications	4
Standard 1000RS Rocking Shaker Control Panel	5
Standard 1000RS Rocking Shaker Operating Instructions	5
Advanced 1000RS Rocking Shaker Specifications	6
Advanced 1000WS Waving Shaker Specifications	7
Advanced Rocking/Waving Shaker Control Panel	8
Advanced Rocking/Waving Shaker Operating Instructions	9-10
Troubleshooting	10
Replacement Parts	11-13
Accessories	14

PACKAGE CONTENTS

Standard 1000RS Rocking Shaker or
Advanced 1000RS Rocking Shaker or
Advanced 1000WS Waving Shaker
Non-skid rubber mat
92" (234cm) detachable power cord
Tier kit (analog rocker 2 tier)
Instruction manual
Warranty card

WARRANTY

Manufacturer warrants this product to be free from defects in material and workmanship when used under normal conditions for five (5) years. Please complete and return the enclosed warranty card. For your reference, make a note of the serial number, date of purchase and supplier here.

Serial Number: _____

Date of Purchase: _____

Supplier: _____

INSTALLATION

Upon receiving the Talboys Rocking/Waving Shaker, check to ensure that no damage has occurred during shipment. It is important that any damage that occurred in transport is detected at the time of unpacking. If you do find such damage the carrier must be notified immediately.

After unpacking, place the Rocking/Waving Shaker on a level bench or table, away from explosive vapors. Ensure that the surface on which the unit is placed will withstand typical heat produced by the unit. Always place the unit on a sturdy work surface.

The Rocking/Waving Shaker is supplied with a power cord that is inserted into the IEC connector on the back of the unit first, then it can be plugged into a properly grounded outlet. The 120V unit plugs into a 120 volt, 50/60 Hz source. The 230V unit plugs into a 230 volt, 50/60 Hz source.

MAINTENANCE & SERVICING

The Rocking/Waving Shaker is built for long, trouble-free, dependable service. No lubrication or other technical user maintenance is required. However at least every three (3) months you should:

- Unplug the unit.
- Remove any accumulated dirt from the base and tray.
- Check all accessible items to make sure they are properly tightened.

The unit should be given the care normally required for any electrical appliance. Avoid wetting or unnecessary exposure to fumes. Spills should be removed promptly. **DO NOT** use a cleaning agent or solvent on the front panel which is abrasive or harmful to plastics, nor one which is flammable. Always ensure the power is disconnected from the unit prior to any cleaning. If the unit ever requires service, contact your Talboys representative.

INTENDED USE

The Rocker/Waver is intended for general laboratory use.

ENVIRONMENTAL CONDITIONS

Operating Conditions: Indoor use only.

*For use in CO₂ environments, incubators or cold rooms.

*Temperature: -10 to 60°C (14 to 140°F).

Humidity: maximum 80% relative humidity, non-condensing

Altitude: 0 to 6,562 ft (2000 M) above sea level

Mains supply voltage: Fluctuations are not to exceed 10 percent of the nominal supply voltage.

Non-Operating Storage:

*Temperature: -20 to 65°C (-4 to 149°F)

Humidity: maximum 80% relative humidity, non-condensing

Installation Category II and Pollution Degree 2 in accordance with IEC 664.

***Avoid cold starts:** Unit is not designed to start after being in a cold room environment. Bring unit into cold room from a room temperature environment, operate and remove unit from cold room as soon as operation is complete.

EQUIPMENT DISPOSAL



This equipment must not be disposed of with unsorted waste. It is your responsibility to correctly dispose of the equipment at life-cycle-end by handing it over to an authorized facility for separate collection and recycling. It is also your responsibility to decontaminate the equipment in case of biological, chemical and/or radiological contamination, so as to protect the persons involved in the disposal and recycling of the equipment from health hazards.

For more information about where you can drop off your waste of equipment, please contact your local dealer from whom you originally purchased this equipment. By doing so, you will help to conserve natural and environmental resources and you will ensure that your equipment is recycled in a manner that protects human health.

SAFETY INSTRUCTIONS

Please read the entire instruction manual before operating the Rocking/Waving Shaker.



WARNING! DO NOT use the Rocking/Waving Shaker in a hazardous atmosphere or with hazardous materials for which the unit was not designed. Also, the user should be aware that the protection provided by the equipment may be impaired if used with accessories not provided or recommended by the manufacturer, or used in a manner not specified by the manufacturer.

Always operate unit on a level surface for best performance and maximum safety.

DO NOT lift unit by the tray.



CAUTION! To avoid electrical shock, completely cut off power to the unit by disconnecting the power cord from the unit or unplug from the wall outlet. Disconnect unit from the power supply prior to maintenance and servicing.

Spills should be removed promptly. Biohazard spills should be cleaned up using approved laboratory procedures. Solvent spills are a fire hazard. Stop the unit immediately, and **DO NOT** operate until clean up is complete and vapors have dissipated (motor brushes arc and may ignite flammable vapors).

DO NOT immerse the unit for cleaning.

DO NOT operate the unit if it shows signs of electrical or mechanical damage.

The main supply cord provided with this product is rated to safely handle the products electrical load under the stated environmental conditions. **DO NOT** replace this cord with an inadequately rated main supply cord.



Earth Ground - Protective Conductor Terminal



Alternating Current

STANDARDS & REGULATIONS

Henry Troemner LLC hereby declares under its sole responsibility that the construction of this product conforms in accordance with the following standards:

Safety standards:

- IEC 61010-1 Safety requirements for electrical equipment for measurement, control and laboratory use. Part I: General Requirements.
- IEC 61010-2-051 Part II: Particular requirements for laboratory equipment for mixing and stirring.

UL Std. No. 61010-1

CSA/CAN C22.2 No. 0-M91

CSA/CAN C22.2 No. 61010-1-04

EMC standards:

- | | |
|--------------|-------------------|
| FCC-B | EN55022-B |
| EN6100-3-3 | EN6100-4-5 |
| EN61000-4-2 | EN61000-4-3 |
| EN61000-4-4 | EN61000-4-6 |
| EN61000-4-11 | EN61326-1 Class A |

Associated EU guidelines:

EMC directive 2004/108/EC

LVD directive 2006/95/EC

RoHS directive 2011/65/EU

CONSIGNES DE SÉCURITÉ

S'il vous plaît lire l'intégralité du manuel d'instructions avant de faire fonctionner l'agitateur orbital.



AVERTISSEMENT! N'UTILISEZ PAS utiliser le secoueur orbital dans un milieu dangereux ou en présence de matières dangereuses non conformes à la conception de l'appareil. L'utilisateur doit également être conscient que la protection assurée par l'équipement peut être amoindrie en cas d'utilisation avec tout accessoire autre que ceux fournis ou recommandés par le fabricant ou en cas d'utilisation contraire aux spécifications du fabricant. Utilisez toujours le dispositif sur une surface à niveau pour optimiser non seulement la performance mais la sécurité.

Toujours utiliser l'appareil sur une surface nivelée pour assurer une performance optimale et un maximum de sécurité.

NE PAS soulever l'appareil en le tenant par le plateau.



MISE EN GARDE! Pour éviter les électrocutions, couper complètement l'alimentation électrique de l'appareil en débranchant le cordon d'alimentation de l'appareil ou de la prise murale. Déconnecter l'appareil de la source d'alimentation électrique avant de procéder à tout entretien ou réparation.

Essuyer immédiatement tout liquide renversé par accident. Déversements de Biohazard doivent être nettoyés à l'aide de procédures de laboratoire approuvées. Déversements de solvants sont un risque d'incendie. Arrêtez immédiatement l'appareil, et ne fonctionnent pas jusqu'à ce que le nettoyage est terminé et vapeurs dissipées (balais pour moteurs arc et peut enflammer les vapeurs inflammables). Ne pas immerger l'appareil pour le nettoyage.

NE PAS immerger l'appareil en vue de son nettoyage.

NE PAS utiliser l'appareil en présence de tout signe de dommage électrique ou mécanique.

Le cordon d'alimentation principal fourni avec ce produit est calibrée pour supporter en toute sécurité le chargement des produits électriques dans les conditions définies. NE PAS remplacer ce cordon avec un cordon d'alimentation principal mal classé.

CONSIGNES DE SÉCURITÉ CONT'D



Mise à la terre - Borne du conducteur de protection



Courant alternatif

NORMES ET RÉGLEMENTATIONS

Henry Troemner, LLC déclare par la présente sous sa seule responsabilité que la conception de ce produit répond aux exigences des normes suivantes:

Normes de sécurité:

- IEC 61010-1 Règles de sécurité pour appareils électriques de mesurage, de régulation et de laboratoire. Partie I: Exigences générales.
IEC 61010-2-051 Partie II: Règles particulières pour les appareils de laboratoire pour le mélange et l'agitation.

UL Std. No. 61010-1

CSA/CAN C22.2 No. 0-M91

CSA/CAN C22.2 No. 61010-1-04

Normes CEM:

- | | |
|--------------|------------------|
| FCC-B | EN55022-B |
| EN6100-3-3 | EN6100-4-5 |
| EN61000-4-2 | EN61000-4-3 |
| EN61000-4-4 | EN61000-4-6 |
| EN61000-4-11 | EN61326-1 Classe |

de l'UE directives:

Directive EMC 2004/108/EC

Directive LVD 2006/95/EC

Directive RoHS 2011/65/EU

STANDARD 1000RS ROCKING SHAKER SPECIFICATIONS



Overall dimensions (L x W x H):	17 x 11 x 5" (43.2 x 27.9 x 12.7cm)
Platform dimensions (L x W):	14 x 11" (35.5 x 27.9cm)
Electrical (50/60 Hz):	120 volts: 15 watts 230 volts: 15 watts
Fuses:	5mm x 20mm, 5 amp quick acting
Speed range:	1 to 75rpm*
Tilt angle:	0 to 15°*
Weight capacity:	16lbs (7.3kg)**
Timer:	1 minute to 120 minutes
Controls:	see page 6
Ship weight:	15.5lbs (7kg)

* Maximum speed/tilt angle may vary with heavy or unbalanced loads.

** Centered on tray.

STANDARD 1000RS ROCKING SHAKER CONTROL PANEL

The front panel of the Analog Rocker contains all the controls and displays needed to operate the unit.

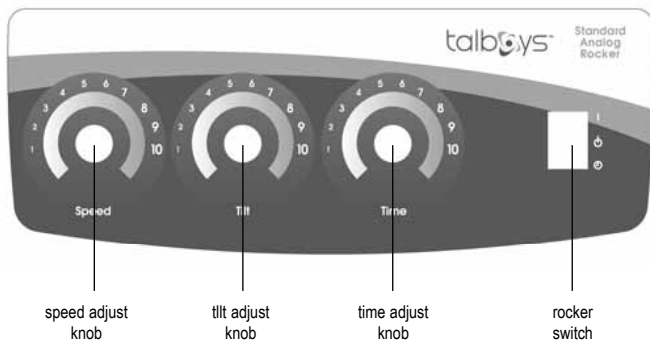

STANDARD 1000RS ROCKING SHAKER OPERATING INSTRUCTIONS

1. Getting ready:

- Rocker switch should be in the center Standby position.
- Plug the power cord into a properly grounded outlet. Manually move the tray to a near horizontal "home" position before powering the unit.
- Position Speed and Tilt knobs between 2 and 3 on the dial.
- Push rocker switch to the "I" On position. The rocker will automatically level and begin running at a moderate speed and tilt.

2. Setting speed and tilt:

- Turn Speed and Tilt knobs to achieve the desired settings.

3. Setting time:

- To run in timed mode, set timer, speed, and tilt knobs to the desired settings.
- Press the rocker switch down to the Time position (⏻) and release.
- The unit will now run for the set time.
- To exit the Time mode, press the rocker switch up and return it to the center Standby position.

NOTE: After the timer is set, any time adjustments will not take affect. To reset time, exit Time mode (see step 3d above) and enter new time following the steps above.

OPERATING TIPS:

Centering your sample and even weight distribution on the tray helps balance and stability.

ADVANCED 1000RS ROCKING SHAKER SPECIFICATIONS



Overall dimensions (L x W x H):	17 x 11 x 5" (43.2 x 27.9 x 12.7cm)
Tray dimensions (L x W):	12.75 x 10" (32.4 x 25.4cm)
Electrical (50/60 Hz):	120 volts: 25 watts 230 volts: 25 watts
Fuses:	5mm x 20mm, 5 amp quick acting
Speed range:	1 to 50rpm *
Speed accuracy:	±1rpm
Tilt angle:	0 to 15° *
Timer:	1 second to 9999 minutes (increased in 1 second increments)
Maximum weight capacity:	10lbs (4.5kg) **
Controls:	see page 4
Tray material:	aluminum
Ship weight:	15.5lbs (7kg)

* Maximum speed/tilt angle may vary with heavy or unbalanced loads.

** Centered on tray.

Advanced 1000RS Rocking Shaker with glassware and plasticware

ADVANCED 1000WS WAVING SHAKER SPECIFICATIONS



Advanced 1000WS Waving Shaker with glassware

Overall dimensions (L x W x H):	17 x 11 x 6" (43.2 x 27.9 x 15.2cm)
Tray dimensions (L x W):	11.75 x 8.75" (29.9 x 22.2cm)
Electrical (50/60 Hz):	120 volts: 25 watts 230 volts: 25 watts
Fuses:	5mm x 20mm, 5 amp quick acting
Speed range:	1 to 30rpm *
Speed accuracy:	±1rpm
Tilt angle:	0 to 20° *
Timer:	1 second to 9999 minutes (increased in 1 second increments)
Maximum weight capacity:	5lbs (2.3kg) **
Controls:	see page 4
Tray material:	aluminum
Ship weight:	16lbs (7.3kg)

* Maximum speed/tilt angle may vary with heavy or unbalanced loads.

** Centered on tray.

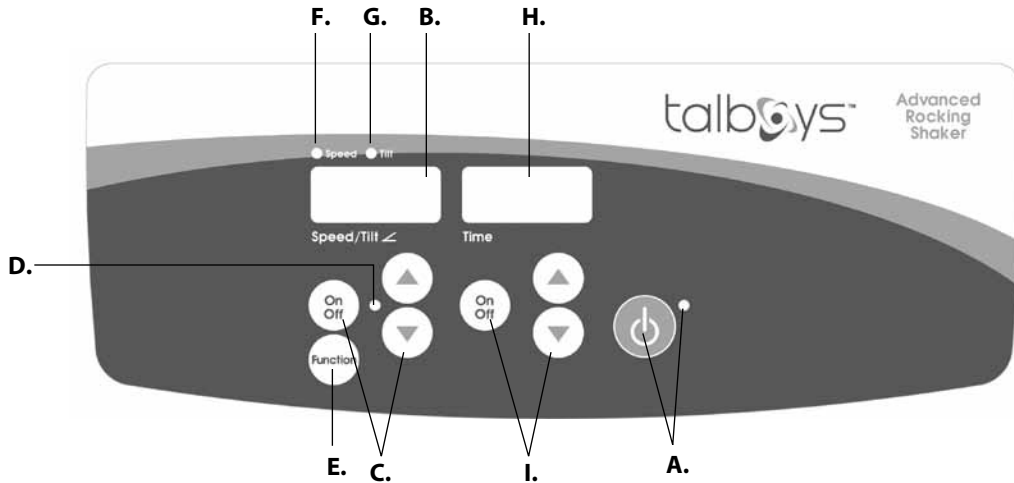

ADVANCED ROCKING/WAVING SHAKER CONTROL PANEL

The front panel of the Rocking/Waving Shaker contains all the controls and displays needed to operate the unit.

A. Standby button/standby indicator light: The standby indicator light will illuminate when the unit is plugged in. The unit will be in standby mode. Press the standby button to activate the speed/tilt angle and time functions. The standby indicator light will shut off and the speed/tilt angle display and time display will illuminate. Press the standby button again and the unit will once again be in standby mode.

B. Speed/tilt angle display: Displays the speed and tilt angle of the unit. **C.** Up/down arrows for set-point control. **On/off** button starts/stops the rocking/waving function. **D.** The speed/tilt angle indicator light will be illuminated when the unit is rocking/waving.

E. Function button: Press to choose the function you are setting: speed or tilt.

F. Speed indicator light: Illuminates when the speed is displayed.

G. Tilt indicator light: Illuminates when the tilt angle is displayed.

H. Time display: Displays accumulated time (continuous mode) or how much time is remaining (timed mode). The display range is from 0 to 9,999 minutes in one (1) second increments. The display will indicate minutes and seconds until the timer reaches 99 minutes and 59 seconds (99:59), then the display will automatically display minutes up to 9,999.

I. Up/down arrows for set-point control. **On/off** button starts/stops the time function

ADVANCED ROCKING/WAVING SHAKER OPERATING INSTRUCTIONS

The Rocking/Waving Shakers have been designed for the speed/tilt angle and time functions to work independently of one another. The speed/tilt angle can be reset without resetting the timer and the timer can be stopped and started without interrupting the rocking/waving function.

1. Getting ready:

- a. Plug the power cord into a properly grounded outlet. The standby indicator light will illuminate, verifying power to the unit. Manually move the tray to a near horizontal "home" position before powering unit.
- b. Press the standby button to move the unit from standby mode. The standby indicator light will turn off and the speed/tilt angle and time displays will illuminate, displaying the previously used settings.



2. Setting tilt angle:

Electronic tilt enables the user to adjust the angle of tray movement while the unit is rocking/waving or while the unit is stopped.

- a. Press the function button below the speed/tilt angle display until the tilt indicator light illuminates. You are now ready to set the tilt angle.
- b. Press the up/down arrows below the speed/tilt angle display until you reach the desired angle. When you release the button, the display will blink off and then on indicating the new set angle has been accepted. The unit will complete one rotation at the previously set angle, then smoothly change to the newly programmed angle. The tilt indicator light will flash until the transition to the new tilt angle is complete.

3. Setting speed:

- a. Press the function button below the speed/tilt angle display until the speed indicator light illuminates. You are now ready to set the speed.
- b. Press the up/down arrows below the speed/tilt angle display until you reach the desired speed. When you release the button, the display will blink off and then on indicating the new set speed has been accepted.

- c. Press the on/off button to start the rocking/waving function. The indicator light below the speed/tilt angle display will illuminate and blink until the set-point is reached. Once the set-point is reached the light will stop blinking and remain lit until rocking/waving has ceased.
- d. To stop the rocking/waving function, press the on/off button below the speed/tilt angle display. The unit will complete one full rotation then stop in the horizontal "home" position. The speed indicator light will flash until the rotation is complete. When the cycle is complete, the unit will automatically move to standby mode and the standby indicator light will illuminate.

OPERATING TIPS

When the unit is running at slow speeds or high angles, making large changes to the tilt angle or speed may take several minutes to complete. The quickest way to make large changes is to stop the unit, change the speed or tilt angle, then restart by pressing the on/off button below the speed/tilt angle display.

4. **Setting time to zero (0:00) and continuous mode:** Accumulated time.
 - a. Press and hold the on/off button below the time display. After three (3) seconds the display will indicate the previous set time.
 - b. Simultaneously press both the up and down arrows, the display will indicate zero (0:00). The unit time is now set to zero (0:00) minutes. Alternately, you can use the up/down arrows to get to zero (0:00).
 - c. Press the on/off button below the time display. The display will indicate accumulated time. The up/down arrows will become inactive. To stop timer, press the on/off button again. **IMPORTANT:** This will **NOT** interrupt the rocking/waving function. Press the on/off button below the speed/tilt angle display to interrupt the rocking/waving function.
 - d. To reset, press and hold the on/off button below the time display. After three (3) seconds the display will indicate the previous set time, which was zero (0:00).

ADVANCED ROCKING/WAVING SHAKER OPERATING INSTRUCTIONS CONT'D

5. **Setting timed mode:** Programmed time.
- Press the up/down arrows below the time display until you reach the desired time.
 - Start this function by pressing the on/off button below the time display. The unit will run for the selected time, the up/down arrows will become inactive while the timer is running. The unit will stop rocking/waving when the time display reaches zero (0:00). Four (4) audible beeps will indicate the count down function is complete. The time display will default back to the set time. To repeat for the same time, simply press the on/off button again.
 - To interrupt an automatic timing cycle before it is completed, press the on/off button below the time display. The time display will flash off and on to indicate the time function is on "hold". **IMPORTANT:** This will **NOT** interrupt the rocking/waving function. Press the on/off button below the speed/tilt angle display to interrupt the rocking/waving function. Restart the timer by pressing the on/off button below the time display. Unit will continue counting down to zero (0:00). When the display reaches zero (0:00), you will hear the four (4) audible beeps that indicate the count down function is complete and the rocking/waving function will cease.
6. **Turning unit off:**
- To turn the unit off, press the standby button. The speed/tilt angle and time displays will be blank, the standby indicator light will illuminate. The Rocking/Waving Shaker should be kept in standby mode when not in use. To completely cut off power to the unit, disconnect the power cord from the unit or unplug from the wall outlet.

OPERATING TIPS

As a safety feature, a built-in program will shut power off to the motor if the tray is prevented from rocking/waving, or the unit is overloaded beyond its recommended weight capacity.

Built-in memory maintains the last used speed/tilt angle and time settings during a power interruption.

TROUBLESHOOTING (STANDARD ROCKING SHAKER)

If the tray motion is obstructed or the unit is mechanically overloaded, the unit will beep and attempt to restore controlled rocking motion. If unit can not recover on its own, disconnect power cord, reduce load, speed or tilt setting and repeat run.

TROUBLESHOOTING (ADVANCED ROCKING/WAVING SHAKER)

During operation, any rattling or ticking sounds may indicate a loose screw on the tray, a tray attachment or an accessory. All accessories should be sufficiently tightened in place before starting the unit.

<u>Error Code</u>	<u>Software Test</u>	<u>Cause</u>
E04	unit overloaded	maximum load exceeded

Press the standby button to clear this error. Be sure the load is within the maximum load capacity before restarting the unit. If the E04 error persists, switch the unit off and contact your Talboys representative for repairs.

<u>Error Code</u>	<u>Software Test</u>	<u>Cause</u>
E03	drive system failure	ceased motor drive belt broken mechanical obstruction

In the event of someone/something inadvertently touching the tray while the unit is running, the unit will display an E03 error message, and automatically go to the horizontal "home" position and restart.

In the event of a mechanical obstruction, the unit will attempt to auto "home" and restart four (4) times and then stop running, displaying an E03 error message. Press the standby button to clear this error and remove the mechanical obstruction.

If the E03 error persists the reason may be a ceased motor or broken drive belt and should **NOT** be addressed by the end user. Switch the unit off and contact your Talboys representative for repairs.

STANDARD 1000RS ROCKING SHAKER REPLACEMENT PARTS

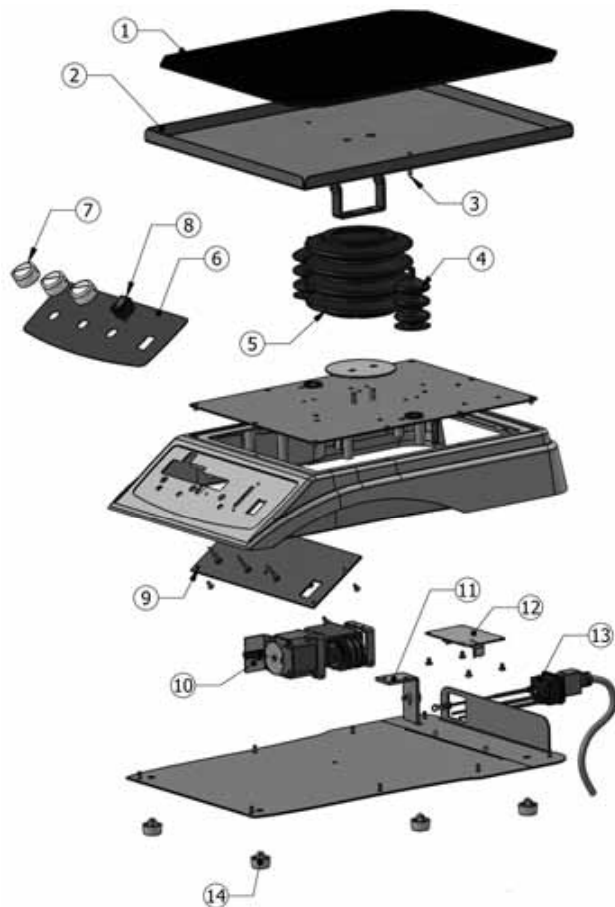

DESCRIPTION	PART NUMBER
1. Non-skid rubber mat	580085-00
2. Tray assembly	880546-00
3. Spring	180175-00
4. Bellows rocker	280436-00
5. Bellows center	280434-00
6. Front panel	380920-00
7. Knob	287010-00
8. Switch assembly	380912-00
9. PCBA	380913-00
10. Motor assembly	880547-00
11. Idler assembly	880548-00
12. Power supply	380910-00
13. IEC wire assembly:	120V: 380790-00
	230V: 380237-00
	Fuse: 380238-00
14. Feet	149023-00
Detachable 92" (234cm) power cord:	120V: 330100-00
	Euro plug: 330101-00
	UK plug: 330102-00
	Swiss plug: 330103-00

ADVANCED 1000RS ROCKING SHAKER REPLACEMENT PARTS

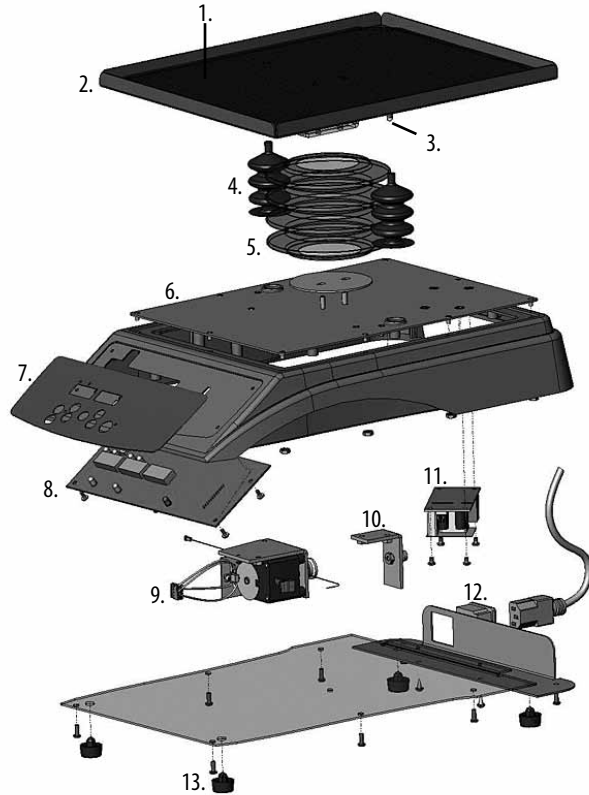

DESCRIPTION	PART NUMBER
1. Non-skid rubber mat	580076-00
2. Tray assembly	880523-00
3. Spring	180062-00
4. Bellows rocker	280436-00
5. Bellows center	280434-00
6. Platform tray	280405-00
7. Front panel	385724-00
8. Circuit board	380735-00
9. Motor assembly	880533-00
10. Idler assembly	880531-00
11. Power supply	386453-00
12. Power entry module:	
	120V:
	230V:
	380755-00
	380237-00
13. Feet	149023-00
14. Fuse (Not Shown)	380238-00
Detachable 92" (234cm) power cord:	120V:
	Euro plug:
	UK:
	Swiss plug:
	330100-00
	330101-00
	330102-00
	330103-00

ADVANCED 1000WS WAVING SHAKER REPLACEMENT PARTS

DESCRIPTION	PART NUMBER
1. Non-skid rubber mat	580077-00
2. Tray assembly	880522-00
3. Spring	180062-00
4. Bellows waver	280435-00
5. Bellows center	280434-00
6. Platform tray	280982-00
7. Front panel	385726-00
8. Circuit board	380735-00
9. Motor assembly	880532-00
10. Idler assembly	880531-00
11. Power supply	386453-00
12. Power entry module:	
120V:	380755-00
230V:	380237-00
13. Feet	149023-00
14. Fuse (Not Shown)	380238-00
Detachable 92" (234cm) power cord:	
120V:	330100-00
Euro plug:	330101-00
UK:	330102-00
Swiss plug:	330103-00

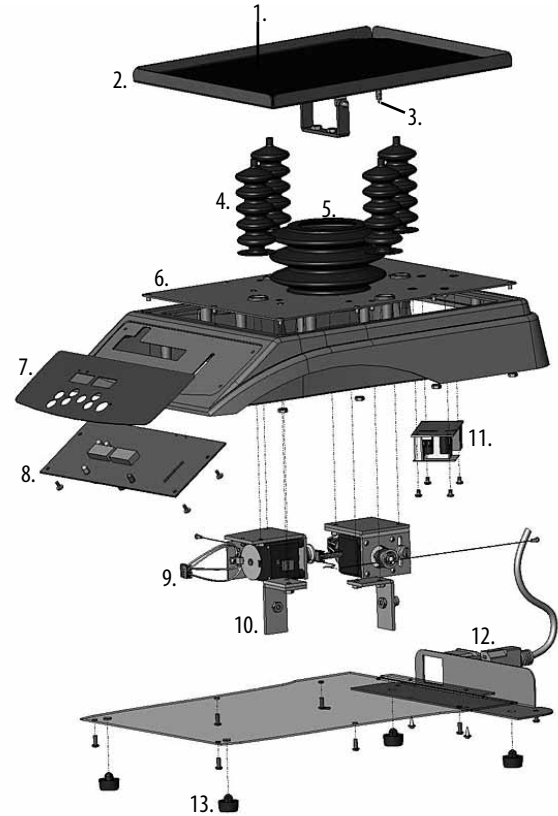

ACCESSORIES

DIMPLED MAT

Designed to hold centrifuge tubes, vials, culture tubes, and micro-tubes securely in place. Mat can be easily removed for cleaning and transporting tubes from bench to tray.

Description	Dimensions (L x W)	Part Number
Dimpled Mat, Standard Rocking Shaker	14 x 11" (35.5 x 27.9cm)	980TADMAR
Dimpled Mat, Advanced Rocking Shaker	12.75 x 10" (32.4 x 25.4cm)	980535
Dimpled Mat, Advanced Waving Shaker	11.75 x 8.75" (29.9 x 22.2cm)	980542



STACKING TRAY

Easily attaches to the lower included tray to add a second tier for higher capacity applications. Second tier tray mounts 3.5" (8.9cm) above the lower tray.

Description	Part Number
Stacking Tray, Standard Rocking Shaker	980TASTKTRAY
Stacking Tray, Advanced Rocking Shaker	980534
Stacking Tray, Advanced Waving Shaker	980541



Manufactured by:



201 Wolf Drive • PO Box 87 • Thorofare, NJ 08086 • Phone: 1-888-TALBOYS • Fax: 856-686-1601

E-mail: troemner@troemner.com • www.troemner.com

715079-00 (REV 10 - 5/15)