

Frontier™ 5306 Mini Centrifuge

Model	FC5306	
Rotor	Angle Rotor	Tube Bank Rotor
Rotating Speed Scope	6000 rpm	
Centrifugal Force	2000 g	
Rotating Direction	Counterclockwise	
Maximum Capacity	8 × 1.5 ml / 2 ml	4 × 0.2 ml-PCR 8-tube bank
		or 32 × 0.2 ml single centrifugal tube
Adapter	0.2 ml / 0.5ml	—
Accelerating Time	≤2 s	
Decelerating Time	≤3 s	
Drive Mode and Motor	Direct drive, with low noise attributable to rolling bearing	
Power Supply	Input: 100-240V ~ 50/60Hz 1.5A Output: 24V $\overline{\text{---}}$ 2.0A	
Dimensions (W × D × H)	5.9 × 6.6 × 5.0 in. / 150 × 168 × 128 mm	
Net Weight	2.3 lb / 1.1 Kg (including free-load angle rotor)	
Shipping Dimensions (W × D × H)	8.5 × 12.0 × 7.6 in. / 216 × 305 × 194 mm	
Shipping Weight	4.1 lb / 1.9 Kg	

Standard Equipment

Mini Centrifuge, AC adapter, Angle rotor (8 × 1.5 ml / 2 ml), 0.2 ml tube bank rotor for PCR 8-tube bank, Eight 0.5 ml adapters and eight 0.2 ml adapters, Manual

Approvals

- **Product Safety:** IEC/EN 61010-1:2010, IEC/EN 61010-2-020:2006
- **Electromagnetic Compatibility:** FCC Part 15 Class B, ICES-001 Class B, EN 61326-1:2013, Class B, Basic environments, IEC 61326-1:2012, Class B, Basic environments

Rotors

Angle Rotor, 8 x 1.5 ml / 2 ml 30129559

Angle Rotor, 4 x 0.2 ml PCR8 30129560

Accessories

Adapter for 0.2 ml Tube (8PCS/Package) 30129561

Adapter for 0.5 ml Tube (8PCS/Package) 30129562

Dimensions

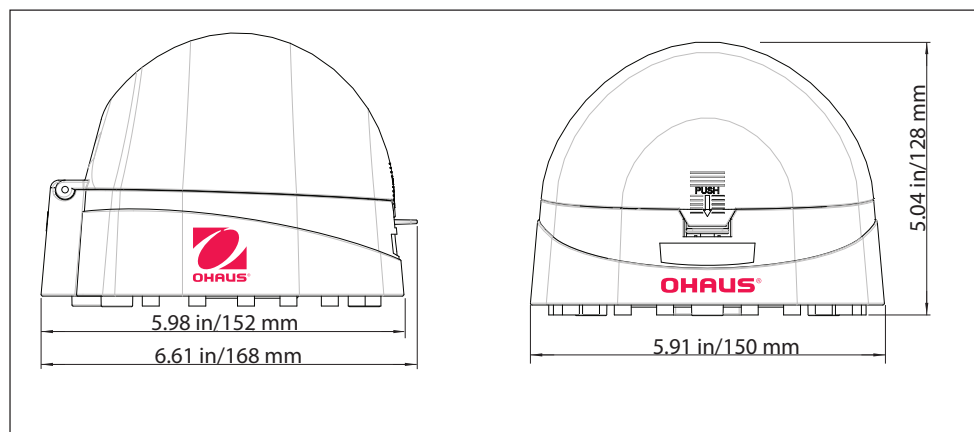

OHAUS CORPORATION

* 7 Campus Drive
Suite 310
Parsippany, NJ 07054 USA

Tel: 800.672.7722
973.377.9000
Fax: 973.944.7177

www.ohaus.com

With offices throughout
Europe, Asia, and
Latin America

*ISO 9001:2008
Registered Quality
Management System

