



New Brunswick™ Innova® 44/44R Shaker

Operating manual

Copyright

Copyright © 2017 Eppendorf AG, Germany. No part of this publication may be reproduced without the prior permission of the copyright owner.

The company reserves the right to change information in this document without notice. Updates to information in this document reflect our commitment to continuing product development and improvement.

Trademarks

Eppendorf® and the Eppendorf logo are registered trademarks of Eppendorf AG, Germany.

New Brunswick™ is a trademark of Eppendorf AG, Germany.

Innova® is a registered trademark of Eppendorf, Inc., USA.

Microsoft® and Windows® are registered trademarks of Microsoft Corporation in the United States and other countries.

Loctite® is a registered trademark of Henkel Corporation, USA.

Trademarks are not marked in all cases with ™ or ® in this manual.

Eppendorf has attempted to identify the ownership of all trademarks from public records. Any omissions or errors are unintentional.

Table of contents

1	Operating instructions	7
1.1	Using this manual	7
1.2	Danger symbols and danger levels	7
1.2.1	Hazard symbols	7
1.2.2	Degrees of danger	7
1.3	Symbols used	8
2	Safety	9
2.1	Intended use	9
2.2	User profile	9
2.3	Application limits	9
2.4	Information on product liability	9
2.5	Warnings for intended use	10
2.5.1	Personal injury and damage to device	10
2.5.2	Incorrect handling of accessories	11
3	Product description	13
3.1	Product overview	13
3.2	General overview	14
4	Inspection and unpacking of equipment	17
4.1	Inspection of boxes	17
4.2	Unpacking of equipment	17
4.3	Packing list verification	17
5	Preparing the location	19
5.1	Physical location	19
5.2	Environment	19
5.3	Electrical requirements	19
5.4	Space requirements	20
6	Installation	21
6.1	Tools required for installation	21
6.2	Install the front grille	21
6.3	Level a single shaker	22
6.4	Level the optional base	23
6.5	Mount Innova 44/44R on optional base	23
6.6	Install the stacking kit	25
6.6.1	For two 44/44R shakers	25
6.6.2	For an Innova 4400/4430 on an Innova 44/44R	27
6.7	Stack two Innova 44/44R shakers	28
6.8	Stack a 4400/4430 on a 44/44R	30
6.9	Stack a third shaker	30

Table of contents

New Brunswick Innova® 44/44R Shaker
English (EN)

7	Features	31
7.1	Controls	31
7.2	LCD display	32
7.3	Changing screens	34
7.4	Display icons	35
7.5	Alarms	36
7.5.1	Optional remote alarm	36
7.6	Glide-up door	36
7.7	Spill pan/water reservoir	36
7.8	Software interfaces	37
7.9	Interior light(s)	37
7.10	Heater	37
7.11	Refrigeration (44R only)	37
7.12	Service accessibility	37
8	Getting started	39
8.1	Platform assemblies	39
8.2	Installation of platform	39
8.3	Install flask clamps	41
8.4	Electrical connections	42
8.5	Optional gassing manifold kit	43
8.6	Optional UV germicidal lamp	43
8.7	Optional photosynthetic lamps	43
8.8	Optional humidity monitor	43
8.9	Fill the water reservoir	44
8.10	Drain the water reservoir	45
9	Operation	47
9.1	Safety precautions	47
9.2	Opening the door	47
9.3	Start the shaker	47
9.4	Using the LCD screens	48
9.4.1	Display screen	48
9.4.2	Summary screen	50
9.4.3	Setup screen	51
9.4.4	Lamps screen	53
9.4.5	RS232 Screen	54
9.4.6	Calibrate screen	56
9.4.7	Programs screen	56
9.5	Program the shaker	57
9.5.1	Timer only	57
9.5.2	Programmed steps	57
9.5.3	Create a program	57
9.5.4	Edit a program	61
9.5.5	Run a program	61
9.6	Mute the audible alarm	61
9.7	Temperature offset calibration	62
9.7.1	Calculate the offset value	62
9.7.2	Set the offset	62
9.8	Using Calspeed	63

9.9	Power interruption	64
9.10	Slide-out platform	64
10	Troubleshooting	67
11	Maintenance	69
11.1	Biohazard decontamination	69
11.2	Routine maintenance	69
11.3	Cleaning external and internal surfaces	70
12	Technical data	71
12.1	Specifications	71
12.1.1	Shaking ¹	72
12.1.2	Temperature ²	72
12.1.3	Unit dimensions ³	72
12.1.4	Gross weight	73
13	Ordering information	75
13.1	Replacement parts	75
13.2	Accessories	75
13.2.1	Replacement clamp hardware kits	75
13.2.2	Test tube racks and other accessories	76
14	Transport, storage and disposal	77
14.1	Transport and storage	77
14.2	Disposal	77
15	Appendix A: Remote programming	79
15.1	Setting up with HyperTerminal	79
15.2	Overview of command sets	80
15.3	Index to command codes	81
15.4	Set commands	81
15.5	Profile control commands	82
15.6	Report request commands	83
15.7	Set/Get date and time	83
	Index	84
	Certificates	87

Table of contents

New Brunswick Innova® 44/44R Shaker
English (EN)







1 Operating instructions

1.1 Using this manual

- ▶ Carefully read this operating manual before using the device for the first time.
- ▶ Also observe the operating manual enclosed with the accessories.
- ▶ The operating manual should be considered as part of the product and stored in a location that is easily accessible.
- ▶ When passing the device on to third parties, be sure to include this operating manual.
- ▶ If this manual is lost, please request another one. The current version can be found on our website www.eppendorf.com.

1.2 Danger symbols and danger levels

1.2.1 Hazard symbols

 <p>Hazard point</p>	 <p>Burns</p>
 <p>Electric shock</p>	 <p>Material damage</p>
 <p>Explosion</p>	 <p>Heavy loads</p>
 <p>Inhalation</p>	

1.2.2 Degrees of danger

The following degree levels are used in safety messages throughout this manual. Acquaint yourself with each item and the potential risk if you disregard the safety message.

DANGER	<i>Will</i> lead to severe injuries or death.
WARNING	<i>May</i> lead to severe injuries or death.
CAUTION	May lead to light to moderate injuries.
NOTICE	May lead to material damage.

Operating instructions

New Brunswick Innova® 44/44R Shaker
English (EN)

1.3 Symbols used

Example	Meaning
▶	You are requested to perform an action.
1. 2.	Perform these actions in the sequence described.
•	List.
	References useful information.

2 Safety

2.1 Intended use

This device is exclusively intended for indoor use and for uniform movement and temperature control of biological solutions and cultures in reaction vessels.

2.2 User profile

The device may only be operated by trained lab personnel who have carefully read this operating manual and are familiar with the device functions.

2.3 Application limits



DANGER! Explosion hazard

- ▶ Do not operate the device in areas where work is completed with explosive substances.
 - ▶ Do not use this device to process any explosive or highly reactive substances.
 - ▶ Do not use this device to process any substances which could create an explosive atmosphere.
-

Due to its design and the ambient conditions in its interior, the device is not suitable for use in potentially explosive atmospheres.

The device may only be used in a safe environment, e.g., the open atmosphere of a ventilated lab. The use of substances which may contribute to a potentially explosive atmosphere is not permitted. The final decision on risks associated with the use of such substances lies with the user.

2.4 Information on product liability

In the following cases, the designated protection of the device may be compromised.

The liability for the function of the device passes to the operator if:

- The device is not used in accordance with this operating manual.
- The device is used outside of the range of application described in the succeeding chapters.
- The device is used with accessories or consumables that were not approved by Eppendorf.
- Service or maintenance is completed on the device by people who are not authorized by Eppendorf.
- The owner has made unauthorized modifications to the device.

Safety

New Brunswick Innova® 44/44R Shaker
English (EN)

2.5 Warnings for intended use

Before using the device, read this operating manual and observe the following general safety instructions.

2.5.1 Personal injury and damage to device

**WARNING! Electric shock due to damage to the device or power cable**

- ▶ Only switch on the device if the device and power cable are undamaged.
- ▶ Only use devices that have been properly installed or repaired.

**WARNING! Lethal voltages inside of the device**

- ▶ Ensure that the housing is always closed and undamaged so the user cannot accidentally touch the parts inside.
- ▶ Do not remove the housing of the device.

**WARNING! Danger due to incorrect power supply**

- ▶ Only connect the device to voltage sources that meet the requirements on the name plate.
- ▶ Only use sockets with a protective earth (PE) conductor and suitable power cable.

**WARNING! Health risk due to contact with infectious liquids and pathogenic bacteria**

- ▶ Observe the national regulations for handling these substances, the biological security level of your laboratory, the material safety data sheets and the manufacturer's application notes.
- ▶ Wear personal protective equipment (PPE).
- ▶ Follow the instructions regarding hygiene, cleaning and decontamination.
- ▶ For complete instructions on the handling of germs or biological material in risk group II or higher, please refer to the "Laboratory Biosafety Manual" (source: World Health Organization).

**WARNING! Health risk due to poisonous, radioactive or aggressive chemicals**

- ▶ Observe the national regulations for handling these substances as well as the material safety data sheets and manufacturer's application notes.
- ▶ Wear personal protective equipment (PPE).

**WARNING! Burns due to hot metal on the device and hot flasks**

- ▶ Only touch the device and flasks when wearing protective gloves.



WARNING! Risk of crushing due to missing auxiliary aid

- ▶ Lifting and transporting the shaker without suitable technical aids can result in crushing and other injuries.
- ▶ Use a hydraulic lifting platform to install and uninstall the shaker.



CAUTION! Risk to health due to lifting heavy loads

- ▶ Only lift the device with another person or using a suitable aid.
- ▶ Make sure to use a transport aid for transportation over long distances.



NOTICE! Damage to electronic components due to condensation

Condensation can form inside the device after the device has been moved from a cool to a warmer environment.

- ▶ Wait at least three hours before connecting it to the mains/power supply.

2.5.2 Incorrect handling of accessories



CAUTION! Lack of safety due to incorrect accessories or spare parts

Accessories and spare parts that are not recommended by Eppendorf compromise the safety, function and precision of the device. Eppendorf cannot be held liable or accept any liability for damage resulting from the use of non-recommended accessories and spare parts.

- ▶ Only use accessories and original spare parts recommended by Eppendorf.



NOTICE! Danger due to damaged tubes

Small scratches and cracks can cause severe damage to the device and accessories. Liquids may escape.

- ▶ Before use, visually check all tubes for any damage.
- ▶ Never use damaged tubes.

Safety

New Brunswick Innova® 44/44R Shaker
English (EN)

3 Product description

3.1 Product overview

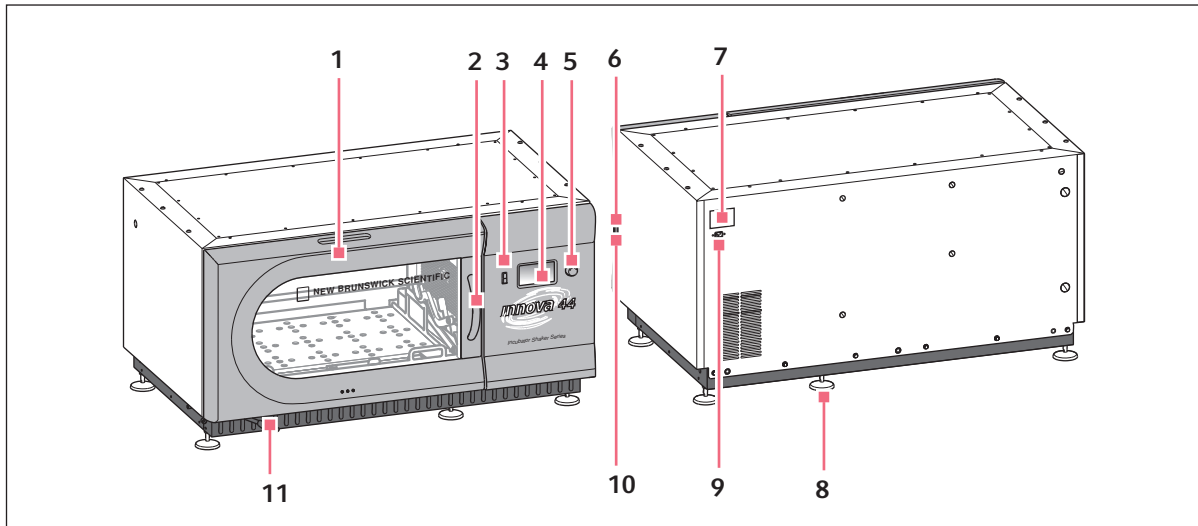

Fig. 3-1: Front and rear view of the Innova® 44/44R

- | | |
|---|---|
| <p>1 Door
With automatic stop function</p> <p>2 Door handle</p> <p>3 Start/Stop switch
Start or stop drive</p> <p>4 Display
Graphical user interface with display of parameters and parameter values</p> <p>5 Push button SELECT control
Change screens, select operating conditions or start or stop drive</p> <p>6 Power switch
Switches device on or off</p> | <p>7 Name plate
Model number, documentation number, serial number and electrical connection data</p> <p>8 Base stand
Align the device horizontally</p> <p>9 Power connection
Connect the power cable</p> <p>10 RS-232 interface
Read out parameter values and control operational functions using computer applications</p> <p>11 Discharge hose
Discharge hose with clamp</p> |
|---|---|

Product description

New Brunswick Innova® 44/44R Shaker
English (EN)

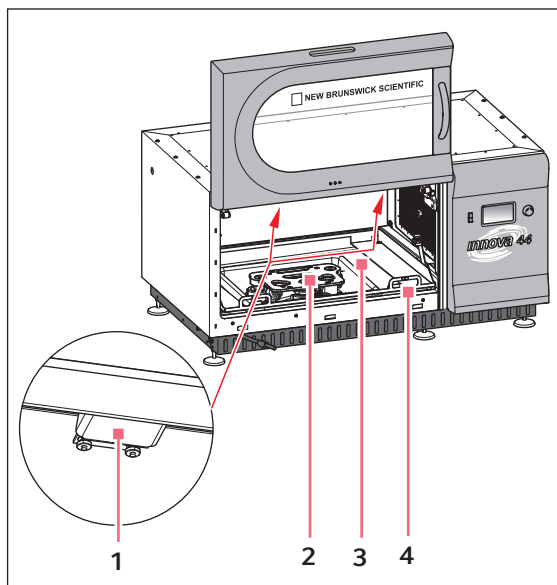

Fig. 3-2: Internal view

1 Halogen lighting**2 Drive**

Eccentric drive

Orbit is model-dependent

3 Spill pan/water reservoir

Catch liquids and store water

4 Platform frame

Remove the platform and platform frame

3.2 General overview

The Innova 44/44R stackable incubator and incubator refrigerated shakers are large-capacity orbital shakers that utilize a triple eccentric counter-balanced drive mechanism. They provide horizontal plane rotary motion in either a 2.54 cm (1 in) or a 5 cm (2 in) diameter circular orbit, depending on the model. A Proportional/Integral (PI) microprocessor controller with instantaneous digital feedback controls the speed over the entire speed range.

The Innova 44R provides temperature control from 20 °C below ambient (as low as 4 °C) to 80 °C, and the Innova 44 from 5 °C above ambient to 80 °C. Naturally, both these ranges depend on relative humidity and other ambient factors, as well as the options installed in the unit. Ambient temperature is measured at one meter from the exterior of the unit.

Erlenmeyer flasks (up to 5 liters in size) as well as a wide variety of tubes and plates can be accommodated using the New Brunswick shaker accessories described in a later section (see *Accessories on p. 75*). These are easily accessed on slide-out platforms.

The Innova 44/44R may be operated in the following ways:

- **Continuously:** at a set speed and temperature, until user intervention.
- **In a timed mode:** run at a set speed, time and temperature for a period of up to 99.9 hours, after which the shaker automatically shuts off.
- **Via the shaker's programmable controller:** run through multiple temperature and speed changes for an extended period of time.

For more details on these various modes of operation, (see *Operation on p. 47*).

For safe operation, the Innova 44/44R shakers are designed with a safety switch that automatically stops the shaker mechanism when the door is opened.

The Innova 44/44R is equipped with visual and/or audible alarms that alert the user to the following conditions:

- The end of a timed run
- Deviations from speed setpoint
- Deviations from temperature setpoint
- Power failure
- Door open
- Unbalanced load

To accommodate customer needs, a wide variety of platforms can be used with the Innova 44/44R:

- Universal platforms are the most flexible, providing hole patterns for flask clamps, test tube racks and other accessories.
- Dedicated platforms are supplied with flask clamps attached; they are designed solely and expressly for this purpose.
- Test tube racks, microplate holders and test tube rack holders are also available (a universal platform is needed for all test tube racks and holders).

For further information on these accessories, (see *Accessories on p. 75*).

Product description

New Brunswick Innova® 44/44R Shaker
English (EN)

4 Inspection and unpacking of equipment

4.1 Inspection of boxes

After you receive your order from Eppendorf, inspect the boxes carefully for any damage that may have occurred during shipping. Report any damage immediately to the carrier and to your local Eppendorf Customer Service Department.

4.2 Unpacking of equipment



WARNING! Risk of crushing due to missing auxiliary aid

- ▶ Lifting and transporting the shaker without suitable technical aids can result in crushing and other injuries.
 - ▶ Use a hydraulic lifting platform to install and uninstall the shaker.
-

To unpack your Innova 44/44R, you will need the following tools:

- Claw hammer
- Forklift or other lifting equipment to lift more than 259 kg (570 lb)
- Shears to cut 19 mm (3/4 in) wide steel strapping
- Tool to remove 7.6 cm (3 in) metal staples

Save all packing materials and this operating manual.

4.3 Packing list verification

Verify against your Eppendorf packing list that you have received all of the correct materials.

If any part of your order was damaged during shipping, is missing pieces, or fails to operate properly, please contact Eppendorf sales representative.

Inspection and unpacking of equipment

New Brunswick Innova® 44/44R Shaker

English (EN)

5 Preparing the location

5.1 Physical location

It is essential that the instrument be situated in an area where there is sufficient space for the shaker and platform to clear walls and potential obstructions during operation. The surface on which the unit is placed must be smooth, level, and able to support the shaker under full load operating conditions.



WARNING! Risk of crushing due to missing auxiliary aid

- ▶ Lifting and transporting the shaker without suitable technical aids can result in crushing and other injuries.
 - ▶ Use a hydraulic lifting platform to install and uninstall the shaker.
-

5.2 Environment

The shaker is designed to operate optimally in the following ambient conditions:

- 10 °C to 35 °C
- 20 % to 80 % Relative Humidity (non-condensing)

5.3 Electrical requirements

The Innova 44/44R can be equipped to run on:

- 100 Volts, 50 Hz, 1500 VA maximum
- 100 Volts, 60 Hz, 1500 VA maximum
- 120 Volts, 60 Hz, 1500 VA maximum
- 230 Volts, 50 Hz, 1500 VA maximum

Check your shaker's Electrical Specification Plate (located on the back of the unit) to be sure the electrical requirements of your unit match the output of your electric supply. If they do not match, contact your Eppendorf representative.

Preparing the location

New Brunswick Innova® 44/44R Shaker
English (EN)

5.4 Space requirements

Allow at least 10 cm (4 in) around the shaker for proper ventilation and for access to Power Switch and RS-232 port accessibility on the right side. Be sure to keep the power plug and power outlet easily accessible to facilitate unplugging the unit, as needed.

Width	135 cm (53 in)		
Depth	84 cm (33 in) including front panel protrusions		
Height	Unit without feet	Unit on medium Base	2 units on medium base
	66 cm (26 in)	96.5 cm (38 in)	162.5 cm (64 in)



Be sure to allow at least 10 cm (4 in) around shaker for ventilation, access to power cord (rear panel), and access to power switch and RS-232 port (right side).



If you are stacking 3 shakers, use a 10 cm (4 in) base.

6 Installation



WARNING! Risk of crushing due to missing auxiliary aid

- ▶ Lifting and transporting the shaker without suitable technical aids can result in crushing and other injuries.
 - ▶ Use a hydraulic lifting platform to install and uninstall the shaker.
-



Feet are used on the shaker **ONLY** when a single unit is operated without a base. At all other times (with two or three shakers stacked, or when a base is added), all feet must be removed.

6.1 Tools required for installation

To install the Innova 44/44R on an optional base and/or to stack Innova 44/44R units, the following tools will be needed:

- Number 2 Phillips head screwdriver
- Blade screwdriver
- 3 mm (1/8 in) Allen key
- 3/8 in Allen key (provided)
- Level, >25.4 cm (10 in)
- Two adjustable wrenches or 7/16 in socket wrench
- Forklift or other lifting equipment able to lift more than 259 kg (570 lb)
- Metal leveling shims (provided in stacking kit)
- Optional: set of screw-in lifting handles, for small lifts of short duration (adding leveling shims, for example) or for minor location adjustments
- Optional: stacking kit(s)

6.2 Install the front grille

1. Remove and discard the plastic retaining clip that holds the drain hose in place for shipping.
2. Temporarily remove the thumbscrews installed at the bottom of each side panel, in the corner closest to the front of the shaker.
3. Hold the front grille in place and reinstall the thumbscrews.

Installation

New Brunswick Innova® 44/44R Shaker
English (EN)

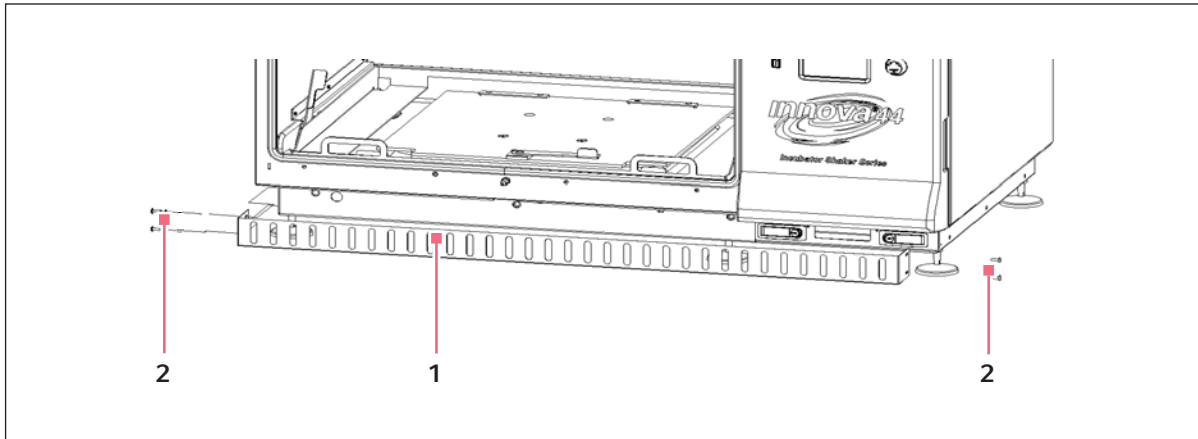

Fig. 6-1: Install the Front Grille

1 Front Grille

2 Thumbscrews

6.3 Level a single shaker

These instructions are for a single shaker without an added base.

Make sure that the shaker is placed on a level surface and that all four feet are solidly on the surface. If the shaker is not level, adjust the feet as needed to achieve leveling:

1. Immobilize the top locknut against the unit with one wrench whenever you adjust the foot, to keep the threaded stud from falling out (see Fig. 6-2 on p. 22).

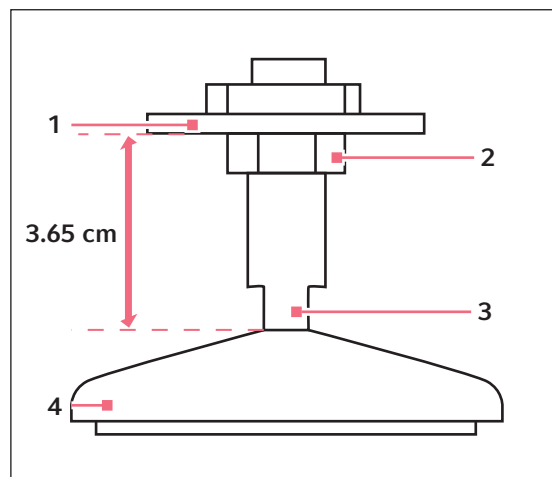

Fig. 6-2: Adjustable Foot (as shipped)

1 Bottom of Unit

3 Flats for Wrench

2 Locknut

4 Foot

2. With a second wrench against the flats of the threaded stud, just above the foot, rotate clockwise to lower the foot or counter-clockwise to raise the foot.
3. Place a level on the top of the unit. If necessary, make further adjustments by repeating all steps until the unit is level.
4. After installing a platform (see *Getting started on p. 39*), fully load the shaker and do a test run at normal speed (see *Operation on p. 47*). Make additional leveling adjustments if necessary.



The maximum shaker lowering adjustment is 12.7 mm (1/2 in). The shaker cannot be raised above the height at which it was shipped. If more adjustment is required, you will need to add metal shims.

6.4 Level the optional base

Place the base on a sturdy (capable of bearing the weight of the combined base shakers and shaker contents), level surface, making sure that all four corners are solidly on the surface. If the base is not level, place metal shims as needed under the base until it is level.



WARNING!

- ▶ Units cannot be stacked without optional base.

Part number	Description
M1282-0500	Stacking kit
M1282-0501	Stacking kit
M1282-0600	10.2 cm base riser, short
M1282-0700	30.5 cm base riser, medium
M1282-0800	40.6 cm base riser, tall

6.5 Mount Innova 44/44R on optional base

1. Using a forklift or lifter, raise the Innova 44/44R so that its back end is tilted toward the rear of the base.
2. Remove all four feet from the bottom of the shaker. They will not be needed for stacking, but you may want to keep them for future use.
3. With two assistants guiding the shaker from opposite sides, lower the unit onto the base, back end first. Slowly and gently remove the forklift or lifter, lowering the front of the unit onto the base by hand.
4. Remove the set screws from the bottom sides of the shaker that correspond to the mounting holes for the rear corner braces (see Fig. 6-3 on p. 24).

Installation

New Brunswick Innova® 44/44R Shaker
English (EN)

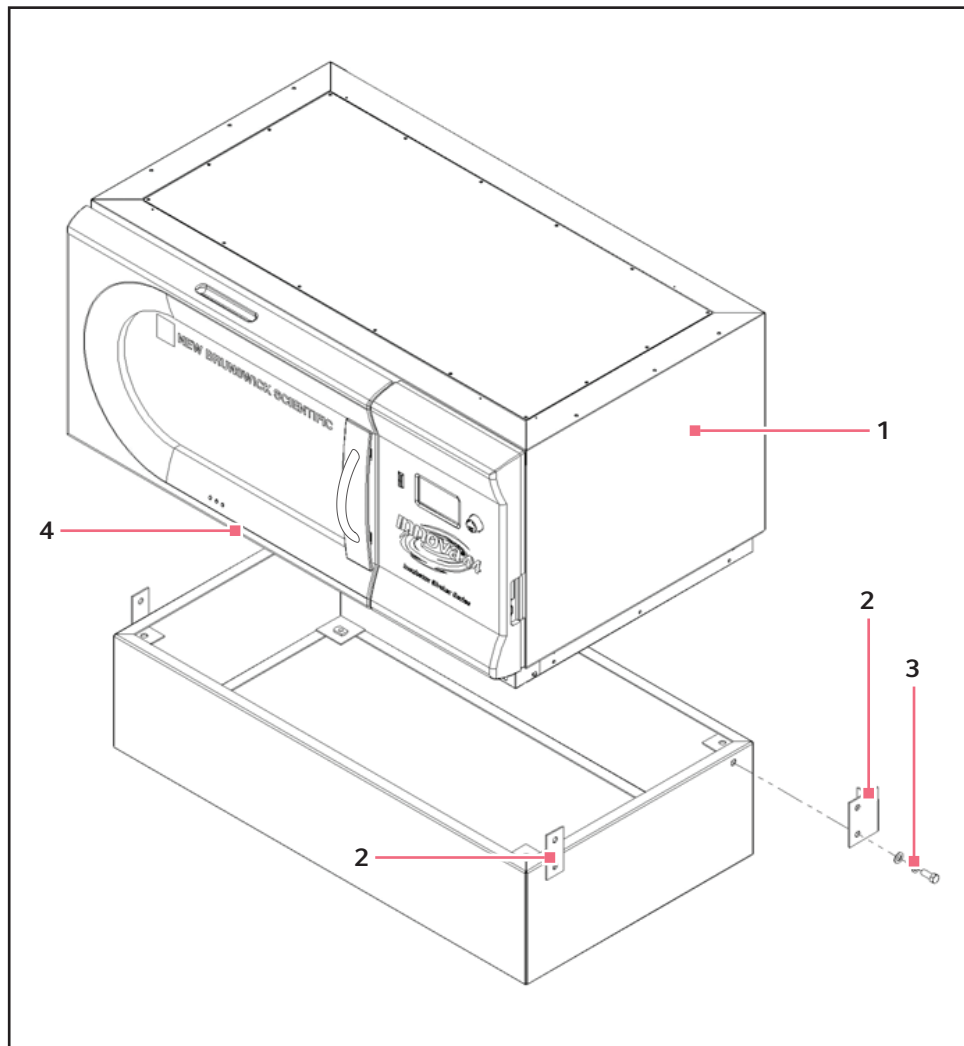

Fig. 6-3: Mount Shaker on Base

1 Innova 44/44R

3 1/2 – 13 x 1 1/4 in screw

2 Remove 1/2 – 13 Set Screws from holes that match corner braces on both sides of unit.

4 Note: Feet removed

5. Using the 1/2 – 13 x 1 1/4 in screws, lock washers and washers provided, mount the rear braces on the base. Do not fully tighten the screws yet.
6. Mount the rear of the Innova 44/44R to the corner braces on the base, using the 1/2 – 13 x 1 1/4 in screws, lock washers and washers provided. Do not fully tighten the screws yet.
7. Mount the front corner braces to the base using two sets of the 1/2 – 13 x 1 1/4 in screws, lock washers and washers provided. Do not fully tighten the screws yet.
8. With the remaining 1/2 – 13 x 1 1/4 in screws, lockwashers and washers, attach the front corner braces to the unit.
9. Tighten all screws equally. With the corner braces securely in place, the shaker mounted on its base will look as shown (see Fig. 6-4 on p. 25):

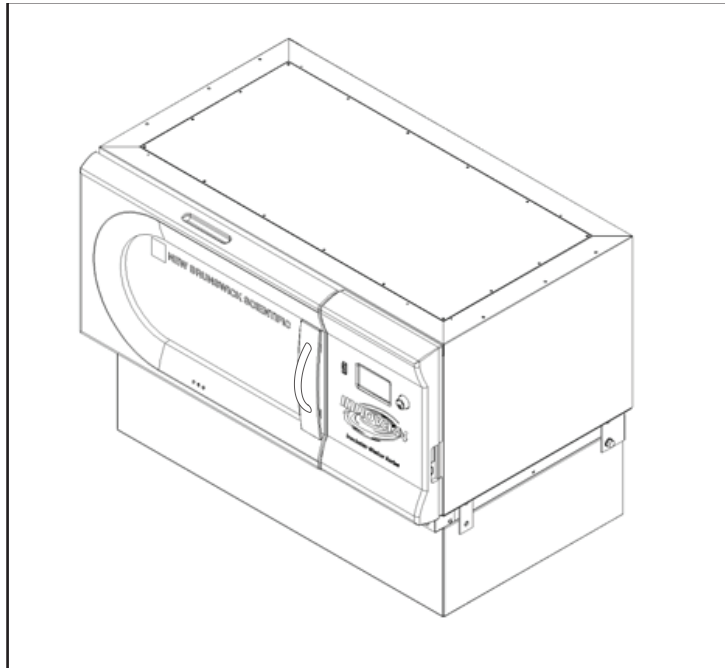

Fig. 6-4: Shaker Installed on Base

10. Make sure the shaker is level; add metal shims under the base as needed to level the unit. Shims are provided with the stacking kit.
11. After installing a platform (see *Installation of platform on p. 39*), fully load the shaker and do a test run at normal speed (see *Using the LCD screens on p. 48*). Make additional leveling adjustments if necessary.

6.6 Install the stacking kit

To stack two Innova 44/44R shakers, (see *For two 44/44R shakers on p. 25*). To stack an Innova 4400/4430 on an Innova 44/44R, (see *For an Innova 4400/4430 on an Innova 44/44R on p. 27*).

6.6.1 For two 44/44R shakers

1. If you do not plan to use an optional base, skip to Step 3 (keeping the feet installed). If you are using one, level the base (see *Level the optional base on p. 23*), then mount the bottom unit on the base (see *Mount Innova 44/44R on optional base on p. 23*). If you are stacking three units, use a 10.2 in base.
2. Remove all feet from the units (put them aside for possible future use).
3. With reference to the figure below (see Fig. 6-5 on p. 26), remove the set screws from the top of the bottom unit, on the two side edges, and remove the set screws (from the sides of the unit to be stacked) that correspond to the mounting brackets.

Installation

New Brunswick Innova® 44/44R Shaker
English (EN)

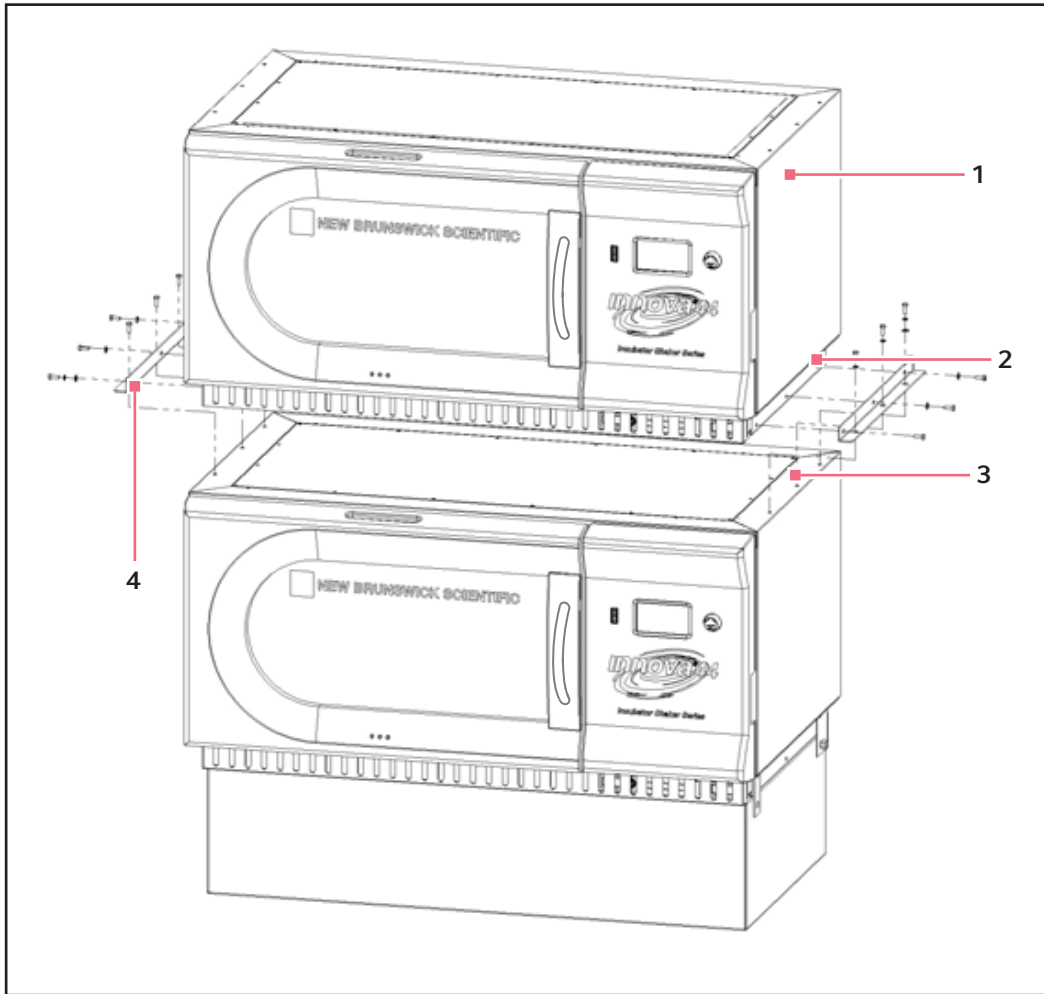

Fig. 6-5: Install Innova 44/44R Stacking Kit

- | | |
|---|--|
| 1 Innova 44/44R | 3 Remove set screws |
| 2 Remove 1/4 – 20 Set Screws before installing stacking kit. | 4 Six sets of 1/4 – 20 x 3/4 in screws, lockwashers and washers on each side. |



Feet are used on the shaker **ONLY** when a single unit is operated without a base. At all other times (when a base is attached or when 2 or 3 shakers are stacked), all feet must be removed.

4. Using the screws and washers provided, attach the stacking kit mounting brackets to the top of the bottom unit. Secure the brackets in place as shown (see Fig. 6-5 on p. 26).

6.6.2 For an Innova 4400/4430 on an Innova 44/44R

1. If you do not plan to use an optional base, skip to Step 3 (keeping the feet installed). If you are using one, level the base (see *Level the optional base on p. 23*), then mount the bottom unit on the base as explained in Section above (see *Mount Innova 44/44R on optional base on p. 23*). If you are stacking three units, use a 4 in base.
2. Remove all feet from the units (put them aside for possible future use).
3. With reference to the figure below (see Fig. 6-6 on p. 27), remove the screws installed at the top of the bottom unit, on the two side edges.

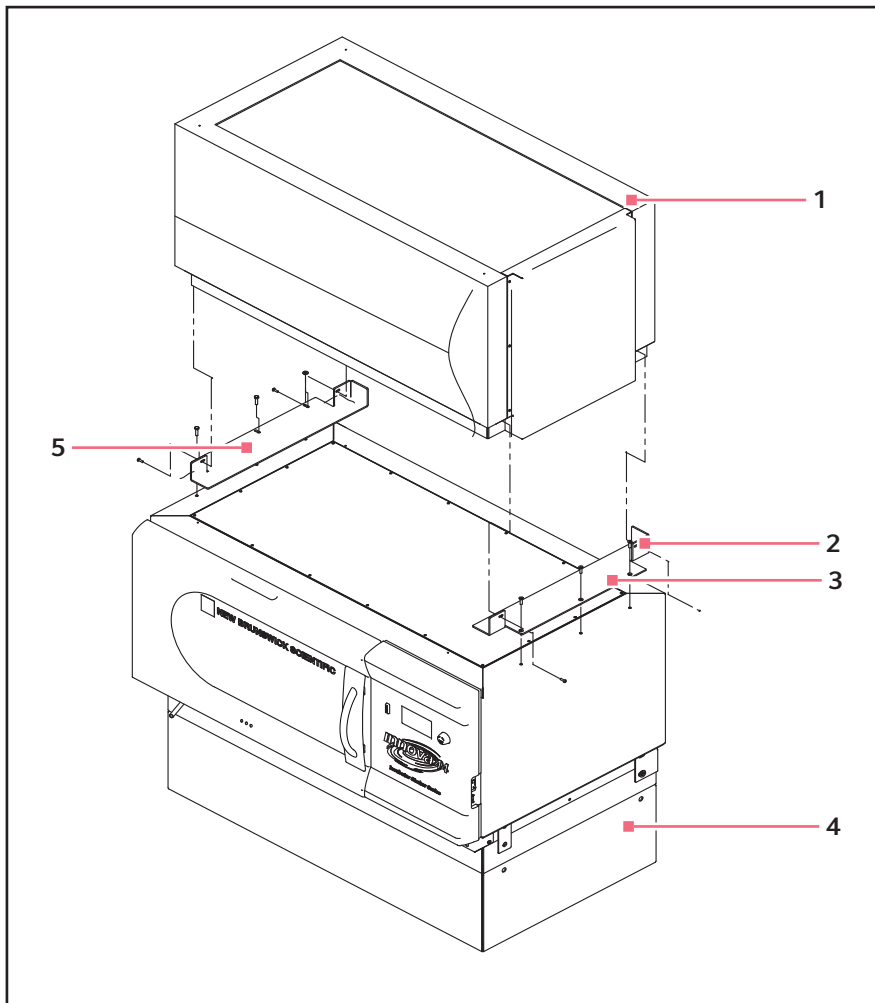

Fig. 6-6: Install 4400/4430 to 44/44R Stacking Kit

- | | |
|--|--|
| 1 Innova 4400/4430 | 4 Optional Base |
| 2 Install right bracket with three 1/4 – 20 x 3/4 in flathead socket screws, with two drops of Loctite® on the threads. | 5 Install left bracket with two sets of 10 – 32 x 1/2 in screws, lockwashers and washers and three sets of 1/4 – 20 x 3/4 in screws, lockwashers and washers. Allow some play until top unit is secure against right bracket, then tighten. |
| 3 Remove screws before installing mounting bracket. | |

Installation

New Brunswick Innova® 44/44R Shaker
English (EN)



Feet are used on the shaker **ONLY** when a single unit is operated without a base. At all other times (when a base is attached or when 2 or 3 shakers are stacked), all feet must be removed.

4. Use the countersunk flathead screws provided, with two drops of Loctite on their threads, to attach the right-hand (facing the door) mounting bracket to the top of the unit installed on the base. Secure the bracket in place.
5. Use the other screws and washers provided to attach the left-hand mounting bracket to the top of the unit installed on the base. Loosely tighten these screws, to allow some play.

6.7 Stack two Innova 44/44R shakers

1. Using a forklift or lifter, raise the Innova 44/44R to be stacked so that its back end is tilted toward the rear of the mounting brackets.
2. Remove the feet from the unit. They will not be needed for stacking, but you may want to keep them for future use.
3. With two assistants guiding the unit from opposite sides, lower the shaker onto the mounting brackets, back end first. Slowly and gently remove the forklift or lifter, lowering the front of the unit onto the mounting brackets by hand.
4. As shown (see Fig. 6-7 on p. 29), secure the bottom of the upper shaker to the mounting brackets (already fastened to the shaker below) with the screws, lock washers and washers provided.

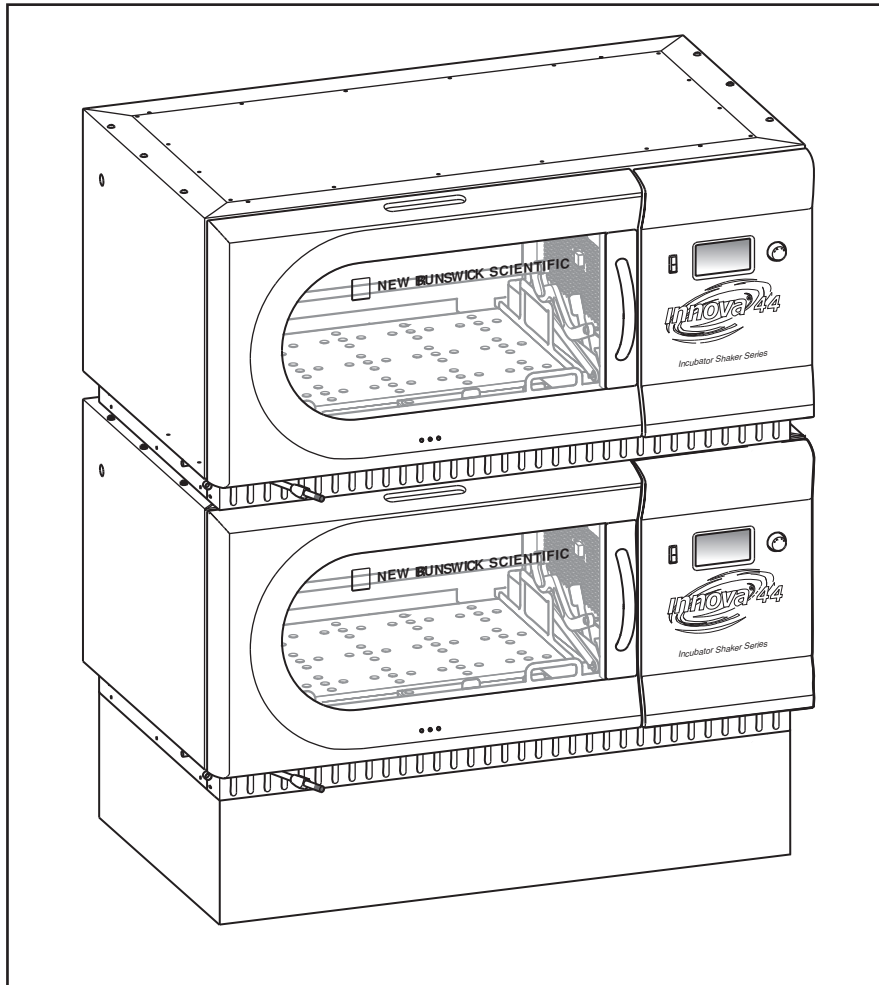

Fig. 6-7: Stacked Shakers

5. Make sure the shakers are level; add metal shims under the bottom unit (or base) if needed.
6. After installing a platform (see *Installation of platform on p. 39*), fully load the shaker and do a test run at normal speed (see *Using the LCD screens on p. 48*). Make additional leveling adjustments if necessary.

If you are stacking a third shaker, (see *Stack a third shaker on p. 30*).

Installation

New Brunswick Innova® 44/44R Shaker
English (EN)

6.8 Stack a 4400/4430 on a 44/44R

1. Using a forklift or lifter, raise the Innova 4400/4430 to be stacked so that its back end is tilted toward the rear of the mounting brackets.
2. Remove the feet from the unit. They will not be needed for stacking, but you may want to keep them for future use.
3. With two assistants guiding the unit from opposite sides, lower the shaker onto the mounting brackets, back end first. Slowly and gently remove the forklift or lifter, lowering the front of the unit onto the mounting brackets by hand and making sure it is tight against the righthand mounting bracket.
4. As indicated (see Fig. 6-6 on p. 27), secure the bottom of the upper shaker to the mounting brackets with the screws, lockwashers and washers provided. Be sure to tighten the right side first, then secure the left side.
5. Make sure the shakers are level; add metal shims under the base if needed.

6.9 Stack a third shaker**CAUTION! Equipment damage**

- ▶ When stacking three shakers, do not use a base taller than 10.5 cm (4 in).
 - ▶ When stacking three shakers, all shaker loads must be balanced. These shakers operate best at maximum speed with a load of 15.5 (± 1.4) kg or 34 (± 3) lb, which includes all platforms, clamps, and filled glassware.
 - ▶ For three stacked 2 in stroke shakers, maximum operating speed must be limited to 250 rpm.
-

To stack a third shaker, repeat the appropriate procedures provided above to install the stacking kit, to stack the shaker, and to level the entire assembly.

7 Features

7.1 Controls

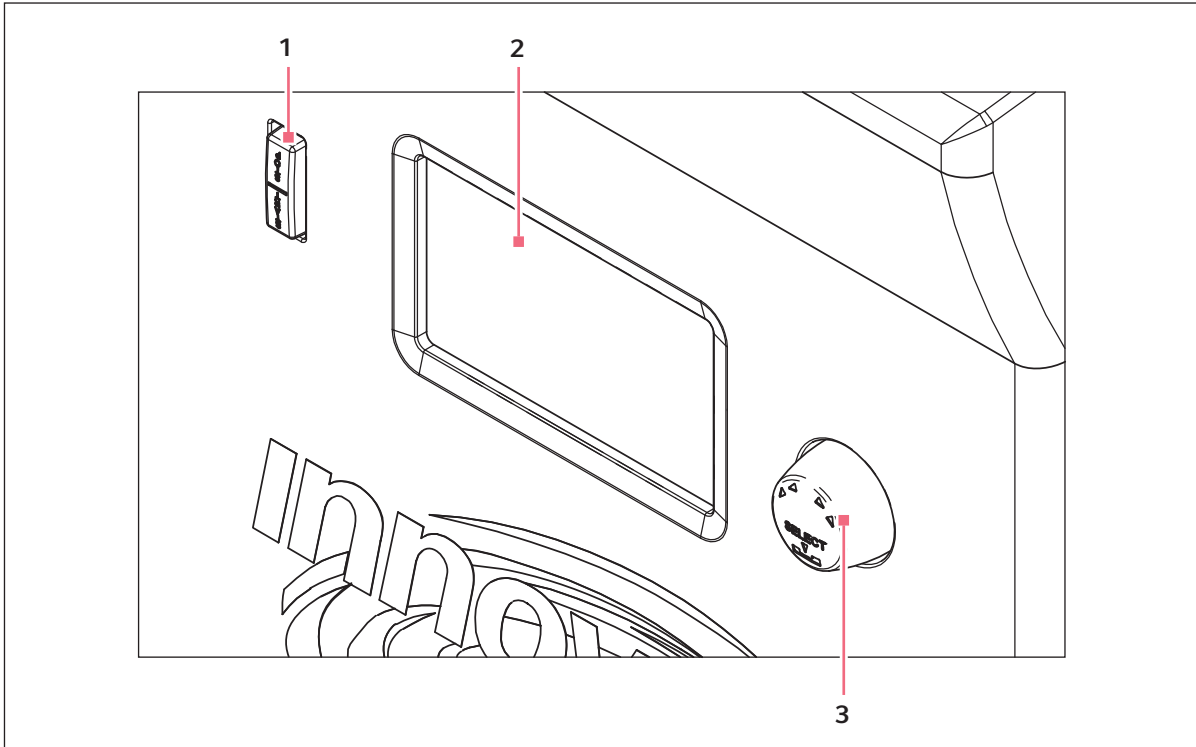

Fig. 7-1: Front panel (detail)

1 Control knob

3 Start/stop switch (for shaking)

2 Display

- **Start/stop switch:** This switch is used to start or stop the shaker. It will also activate the timer when a timed run is desired. If the unit is stopped and restarted, the timer automatically returns to the beginning of a run.
- **Control knob:** This knob is multifunctional. It is used to change screens and to select and change operating conditions.
- **RS-232 port:** For details (see *Software interfaces on p. 37*).
- **Power switch:** This rocker switch is a circuit breaker that turns power on and off to the entire Innova 44/44R.



In addition to the power switch, the power cord is also used to conduct power or to break the power circuit to the shaker. Whenever power to the shaker may be a hazard (during cleaning, maintenance or service work), be sure to disconnect the power cord from the electrical outlet.

Features

New Brunswick Innova® 44/44R Shaker
English (EN)

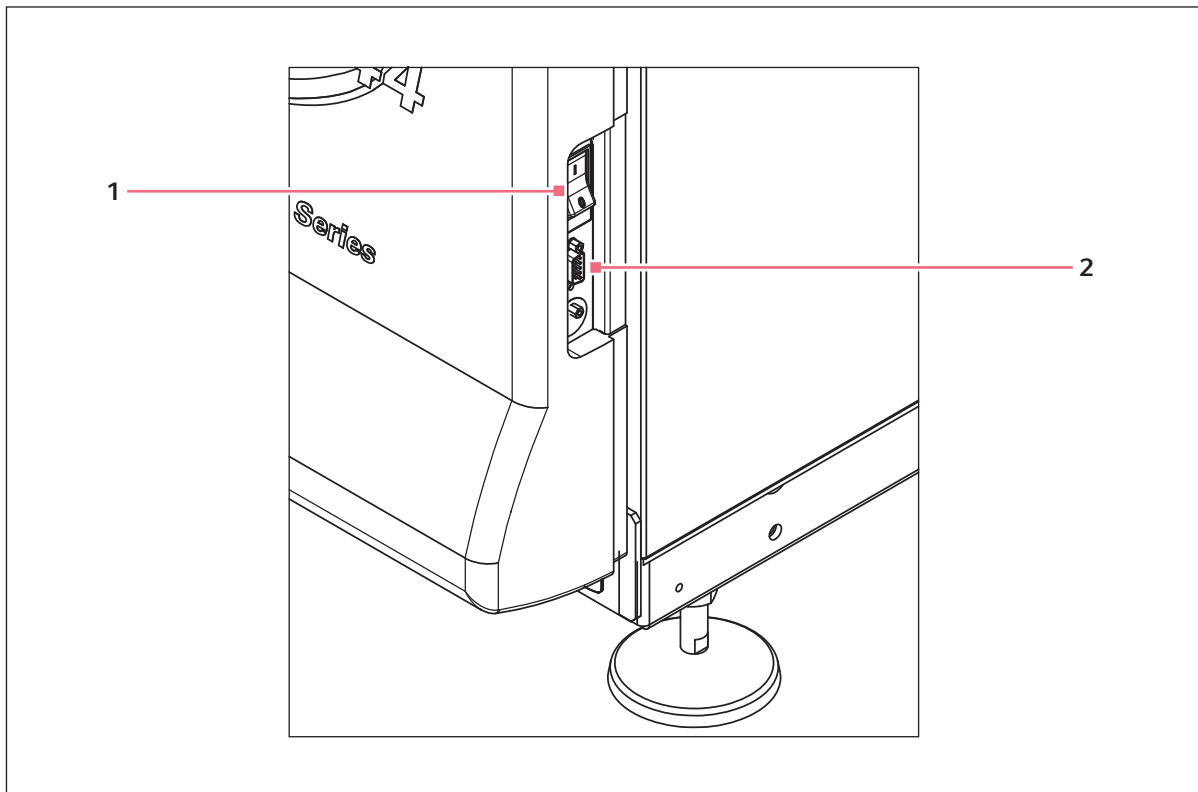

Fig. 7-2: Control panel (right side)

1 Power switch

2 RS-232 port

7.2 LCD display

When the unit is powered up, using the power switch located on the lower right side of the machine (see Fig. 7-2 on p. 32), the initial display screen will remain for a short time while the system boots up. Then the main screen, called *DISP* for Display, appears (see Fig. 7-3 on p. 33). This screen will indicate the same parameters that were in effect when the power was turned off.

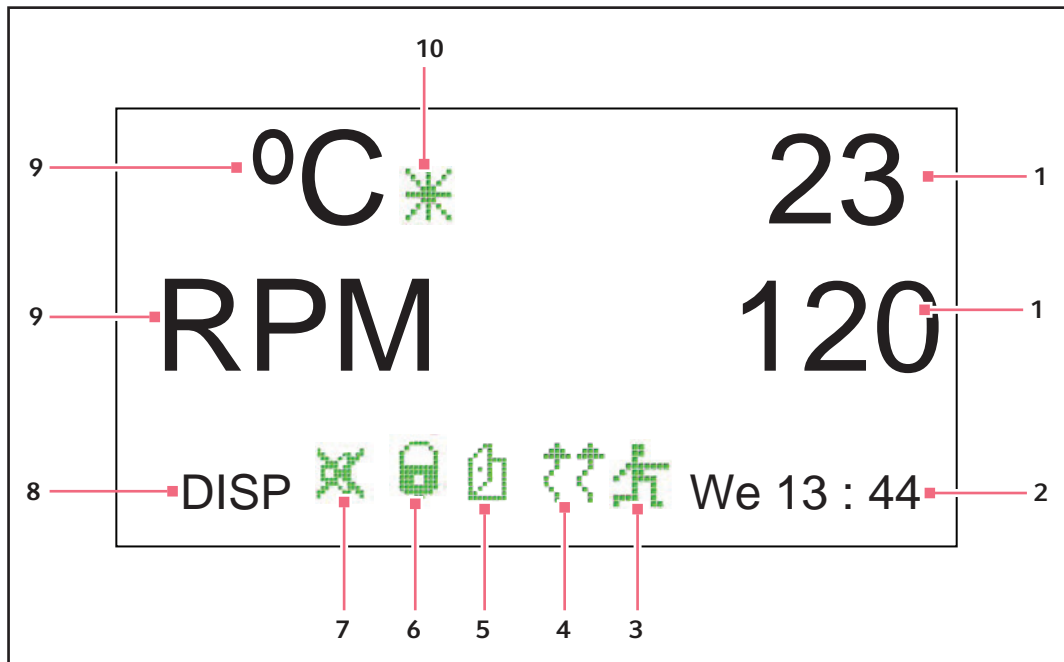

Fig. 7-3: Display screen

- | | |
|---------------------------|-----------------------|
| 1 Actual parameter values | 6 Parameters locked |
| 2 Day and 24-hour time | 7 Audible alarm muted |
| 3 Program running | 8 Screen name |
| 4 Heater on | 9 Parameters |
| 5 Door open | 10 Temperature offset |

- For an explanation of the icons on the display screen, (see *Display icons on p. 35*).
- Turning the control knob will highlight functions and/or values that can be changed.
- Whenever you turn the control knob, the chamber light will go on (see *Interior light(s) on p. 37*).

For more information on working in the *Display* screen, (see *Using the LCD screens on p. 48*).

Features

New Brunswick Innova® 44/44R Shaker
English (EN)

7.3 Changing screens

You can change screens displayed by highlighting the screen name field in the lower left corner, pressing the control knob in until it clicks, rotating the knob left or right (which also makes clicking sounds) to the desired screen and clicking the control knob in again. The following table describes the various screens:

Tab. 7-1: Screens

Screen Name	Meaning	Features/Modes
<i>DISP</i>	Display	Shows 2 user-selectable parameters ¹ and actual values
<i>SUMM</i>	Summary	Shows all: parameters ¹ , setpoints, and actual values
<i>SET</i>	Set-Up	<ul style="list-style-type: none"> • Set day of week • Set time • Enable or mute alarm • Lock or unlock operating parameters
<i>LAMP</i>	Lamps	<p>Internal chamber light:</p> <ul style="list-style-type: none"> • ON (always on) • OFF (always off) • AUTO (default mode), light goes on and stays on when door is open, shuts off 15 seconds after door is closed, and goes on for 15 seconds when control knob is moved <p>Photosynthetic lights (GRO)²:</p> <ul style="list-style-type: none"> • ON • OFF • NONE³ <p>UV Light (UV)²:</p> <ul style="list-style-type: none"> • ON • OFF • NONE³
<i>COMM</i>	Communication (RS-232)	<p><i>SET</i>:</p> <ul style="list-style-type: none"> • Set baud rate • OFF disables RS-232 <p><i>MONITOR</i>:</p> <ul style="list-style-type: none"> • PC commands shaker to read setpoints and actual values on a schedule determined by PC software • Parameters are unlocked and can be changed by program or manually <p><i>SLAVE</i>:</p> <ul style="list-style-type: none"> • PC controls shaker and logs data <p><i>TALK</i>:</p> <ul style="list-style-type: none"> • Shaker sends setpoint and actual data to PC at one-minute intervals
<i>CAL</i>	Calibration	Allows user to enter a temperature offset and calibrate speed
<i>PROG</i>	Program	• Allows user to set up 1 – 4 programs, each with 1 – 15 steps







Tab. 7-2: Display Screen Parameters

Parameter Name	Meaning
RPM	Shaking speed, in revolutions/minute
°C	Chamber temperature, in degrees Celsius
HRS	Programmed time remaining, in hours
%RH ¹	Relative Humidity, in percent
UV ¹	Status of Ultraviolet germicidal lamp
GRO ¹	Status of Photosynthetic growth lamps

¹ Optional

7.4 Display icons

Tab. 7-3: Display Icons

Icon	Explanation
	Audible alarms are muted.
	Manual/program-controlled changes to parameters are disabled.
	Door is open.
	Heater is on.
	User-defined program is running.
	Temperature offset is used.

Features

New Brunswick Innova® 44/44R Shaker
English (EN)

7.5 Alarms

If an alarm condition exists, the field in the lower right corner will alternate the Day and Time with characters indicating the nature of the alarm condition, accompanied by an audible alarm (unless muted) (see Table below):

Indication	Description
TEMP	The temperature deviates more than ± 1 °C from setpoint after achieving control temperature range. After door is opened, alarm will be disabled for 5 minutes while chamber recovers to setpoint.
RPM	The speed deviates more than ± 5 RPM from setpoint after achieving operating speed setpoint. After door is opened, alarm will be disabled for 5 minutes while chamber recovers to setpoint.
POWER	Indicates unit is powering up (both at normal power-up and after power interruption); will flash until the Control Knob is moved.
HRS	Indicates when timed run is completed.
TILT	Indicates an unbalanced shaking condition. After load is evenly distributed and/or shaker is leveled, restart by pressing START/STOP.

7.5.1 Optional remote alarm

The Innova 44/44R can be equipped with a factory-installed remote alarm component (part number M1320-8029). When it is hooked up to your relay and receiving equipment, this device will send notification of an alarm condition to the remote location you choose.

7.6 Glide-up door

The Innova 44/44R is equipped with a space-saving glide-up door.

When the door opens, the following will happen:

- Heater turns off
- Shaker stops
- Interior light goes on and, when it is in AUTO mode, will remain on for 15 seconds after the door is closed
- UV germicidal lamp (if so equipped) turns off
- Photosynthetic lights (if so equipped) turn off.

7.7 Spill pan/water reservoir

The Innova 44/44R is equipped with a spill pan to protect the drive mechanism in the case of accidental spills and/or broken glassware. This pan can also be used as a water reservoir to humidify the chamber and to reduce evaporation. An optional factory-installed humidity monitor is also available.

7.8 Software interfaces

The RS-232 port is located below the power switch on the right side of the control panel (see Fig. 7-2 on p. 32). It can be used to interface a PC to the shaker for control of operating conditions or data logging applications (see *Appendix A: Remote programming on p. 79*).

The customer is responsible for securing the proper driver to interface with the RS-232.

7.9 Interior light(s)

When the LAMP screen is in its default AUTO mode, the interior (“chamber”) light is activated for 15 seconds whenever you turn the Control Knob. It will automatically shut off after 15 seconds of Control Knob inactivity.

The chamber light will also go on when the door is open.

In addition, you can set the chamber light to be continuously ON or OFF by selecting either mode in the LAMP screen.

There are two additional light options for refrigerated units only: interior photosynthetic growth lamps (see *Optional photosynthetic lamps on p. 43*) and a UV germicidal lamp located outside the chamber but in the airflow path (see *Optional UV germicidal lamp on p. 43*).

7.10 Heater

The chamber temperature is sensed by a 1000 ohm platinum RTD. A 650 W heater is controlled using pulse width modulation on a 2.5 s duty cycle. This cycle time is fast enough to prevent noticeable changes in air temperature due to the cycling.

Whenever the heater is on, the Heater On icon will appear in the display. The heater automatically stops running when the door is opened.

7.11 Refrigeration (44R only)

The refrigeration system in the Innova 44R is a fixed-capacity system carefully designed to maintain the setpoint, to balance pressure within the system, and to prevent freezing on the evaporator surface.

When the shaker is powered up, there is a four-minute time delay prior to compressor start-up.

7.12 Service accessibility

In the unlikely event that your Innova 44/44R should need service, all electronic boards, refrigeration and heating components are mounted on a pull-out drawer mechanism which is easily accessed, **by an authorized service technician**, from the front of the shaker.

Features

New Brunswick Innova® 44/44R Shaker
English (EN)

8 Getting started

8.1 Platform assemblies

The Innova 44/44R can be used with a variety of Eppendorf platforms that will accept a wide range of clamps for flasks, test tubes, etc. A platform, which is required for operation, is a separate item, not included with the shaker assembly. For details on available platforms and platform accessories, (see *Accessories on p. 75*).

8.2 Installation of platform

- i** In transit, there are two small plastic straps on the side of the bearing housing to secure the slide-out mechanism and two small plastic straps that immobilize the bearing housing; all straps must be removed.
- i** When you cut the bearing housing straps, be particularly careful not to cut the wiring that is in close proximity to the straps.

Prior to use, a subplatform and platform must be installed on the unit. The shaker is shipped with four Allen head platform screws installed in the bearing housing, (see Fig. 8-1 on p. 39).

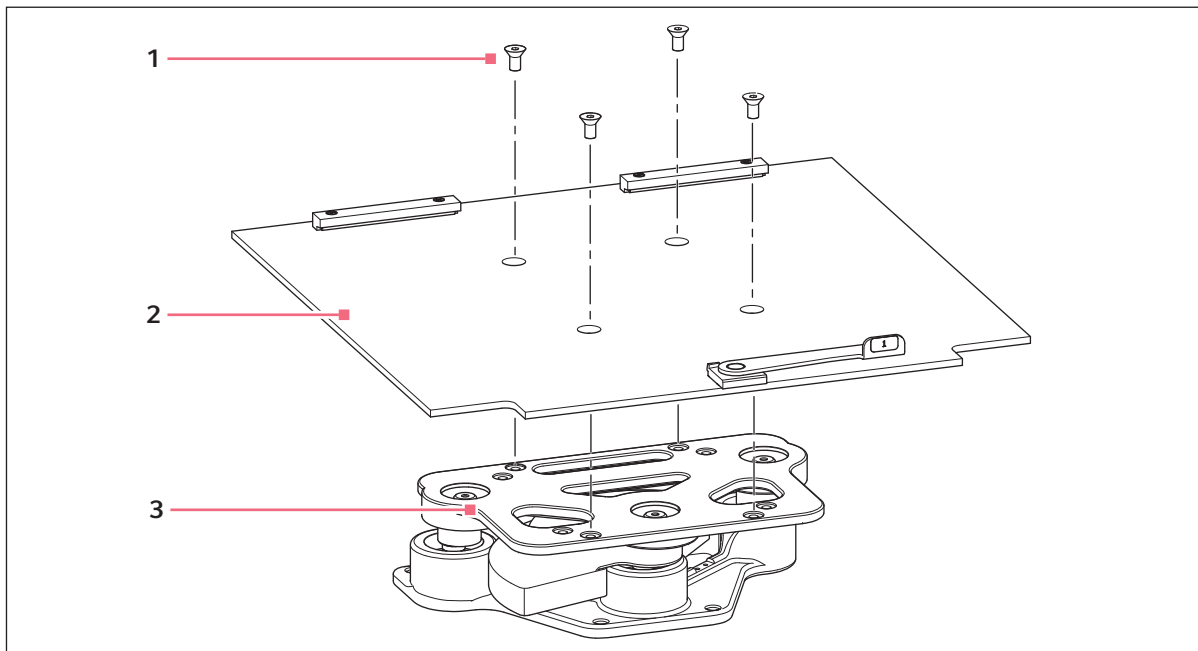

Fig. 8-1: Install Subplatform

1 Platform screws

3 Bearing housing

2 Sub-platform

Getting started

New Brunswick Innova® 44/44R Shaker
English (EN)

1. Remove the Allen head platform screws, setting them aside.
2. Place the subplatform onto the bearing housing, taking care to orient it as shown (see Fig. 8-1 on p. 39), with the notches and the lever toward the front of the shaker, lever facing up.
3. Align the subplatform holes with the tapped holes in the bearing housing, then secure the subplatform with the Allen head platform screws you previously removed.

To install the slide-out platform you have purchased:

1. With reference to figure below (see Fig. 8-2 on p. 40), place the platform on the subplatform, making sure the two slots in the back of the platform are inserted under the subplatform's blocks in the back, and the slide-out tray handles are at the front edge, facing up.
2. Rotate subplatform cam lever 180 ° counterclockwise (away from you), until it points to the right. This locks the platform in place.
3. Simultaneously push both side cam levers up (away from you and toward the back of the chamber).
4. Push both slide-out tray handles away from you until the platform hits its stops at the back of the chamber.

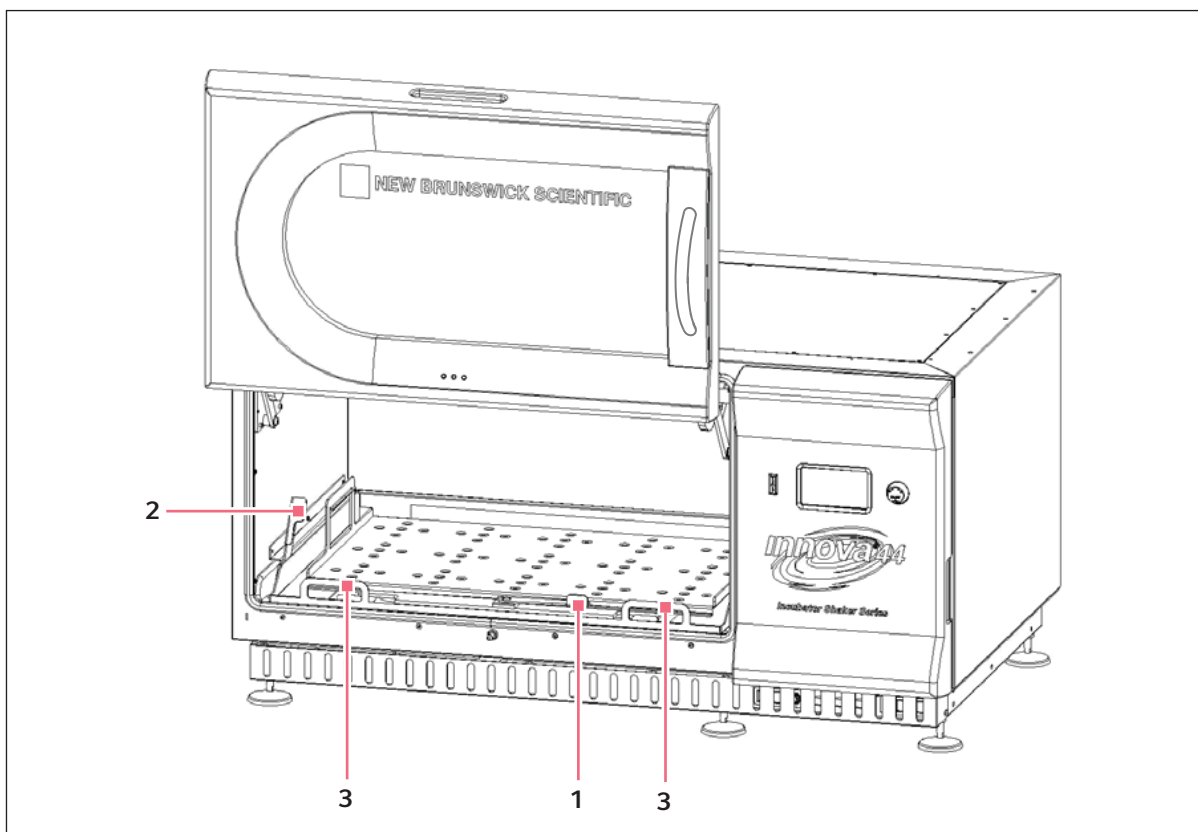

Fig. 8-2: Install Slide-Out Platform

1 Sub-platform cam lever

3 Slide-out tray handles

2 Side cam levers

8.3 Install flask clamps

Flask clamps purchased for use with universal platforms (see *Accessories on p. 75*) require installation. Clamps are installed by securing the base of the clamp to the platform with the correct type and number of screws. All clamps are shipped complete with hardware.

Clamps for 2, 2.8 and 4 liter flasks are shipped with an additional girdle to keep the flasks in place. The girdle is an assembly of springs and sections of rubber tubing. One girdle is already in place on the clamp, the other is packed separately. To install these double girdle clamps:

1. Place the clamp on the platform, aligning its mounting holes with holes on the platform. Secure the clamp in place using the flat Phillips head screws provided (# S2116-3051, 10 – 24 x 5/16 in). To help you identify the proper screws, (see Fig. 8-4 on p. 42), as 3 different types of screws are shipped with the clamps.
2. With the first girdle in place, as delivered, on the upper part of the clamp body (see Fig. 8-3 on p. 41), insert an empty flask into the clamp.
3. After making sure the sections of tubing are located between the clamp legs, roll the first girdle down the legs of the clamp as far as it can go. The tubing sections will rest against the platform, and the springs will be under the clamp base.
4. Place the second girdle around the upper portion of clamp body (just as the first girdle was initially). Make sure that its spring sections rest against the clamp legs, while its rubber tubing sections sit against the flask, in between the clamp legs.

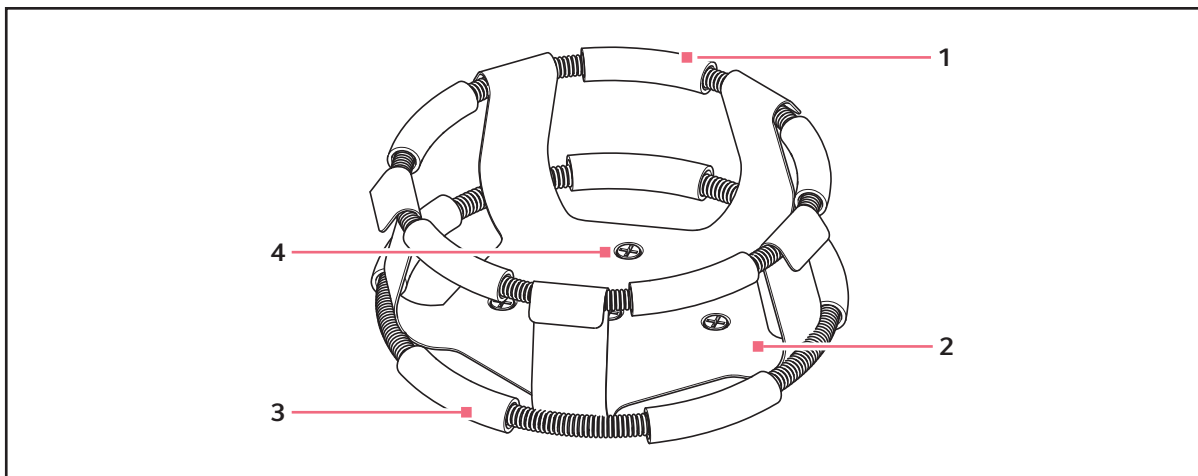

Fig. 8-3: Double girdle clamp installation

1 Upper girdle with girdle tubes

3 Lower girdle with girdle tubes

2 Clamp body (legs and base)

4 Clamp mounting holes (5)

Getting started

New Brunswick Innova® 44/44R Shaker
English (EN)

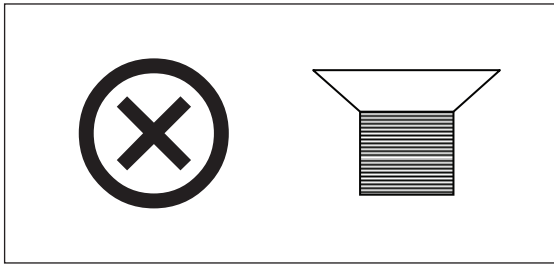

Fig. 8-4: Clamp fastener



The upper girdle secures the flask within the clamp, and the bottom girdle keeps the flask from spinning.

8.4 Electrical connections

Before making electrical connections, verify that the power source voltage matches the voltage on the electrical specification plate and that the ON/OFF switch is in the OFF position. The electrical specification plate is located on the rear panel of the unit near the power connector.

Connect the power cord to the power connector, then connect the other end to a suitable, grounded receptacle. Make sure there is enough clearance to disconnect the plug whenever necessary.

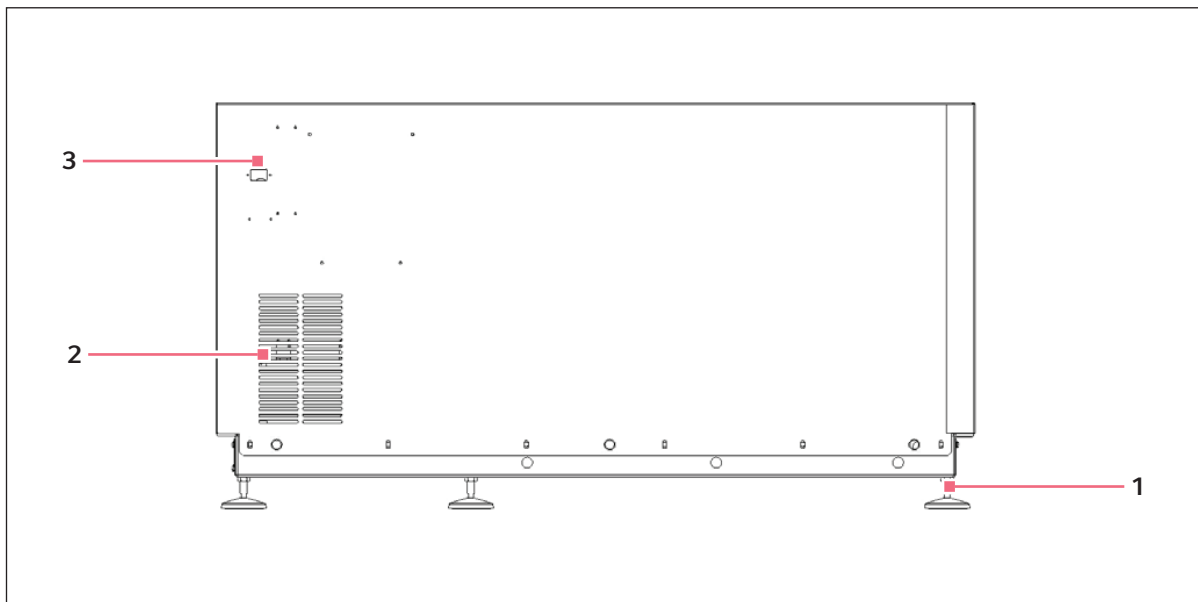

Fig. 8-5: Rear panel

1 Adjustable foot

3 Power connector

2 Air intake vents (do not block)

8.5 Optional gassing manifold kit

This option is factory-installed. The manifold delivers gas into the chamber and ultimately into the flasks themselves via twelve ports. You may elect to use splitters after the manifold to increase the number of ports for your application.

8.6 Optional UV germicidal lamp



WARNING! Personnel injury and equipment damage!

- ▶ Never try to operate the UV Germicidal Lamp while the shaker door is open.
-

This option, a germicidal ultraviolet lamp, is placed inside the Service Drawer, outside the chamber to help reduce the risk of contamination. The lamp is identified on the display screen as UV.

The UV germicidal lamp is factory-installed and available on refrigerated units only.

8.7 Optional photosynthetic lamps

This factory-installed option (for refrigerated units only) provides nine photosynthetic growth lamps inside the chamber. They can be turned on and off manually, by the easily set programmable timer, or by computer. These lamps are identified on the display screen as GRO. The replacement bulb part number is P0300-0221.

The recommended operating temperature when using this option is 15 °C – 37 °C.

The maximum operating temperature when using photosynthetic lamps is 70 °C.

8.8 Optional humidity monitor

This optional factory-installed accessory allows you to monitor actual humidity levels in the chamber throughout your run. With humidity monitor, the maximum temperature is 60 °C.

Getting started

New Brunswick Innova® 44/44R Shaker
English (EN)

8.9 Fill the water reservoir

If you choose to use the spill pan/reservoir as a water reservoir to reduce evaporation:

1. Temporarily remove the 4 thumbscrews that secure the front grille in place (Fig. 8-6 on p. 44).

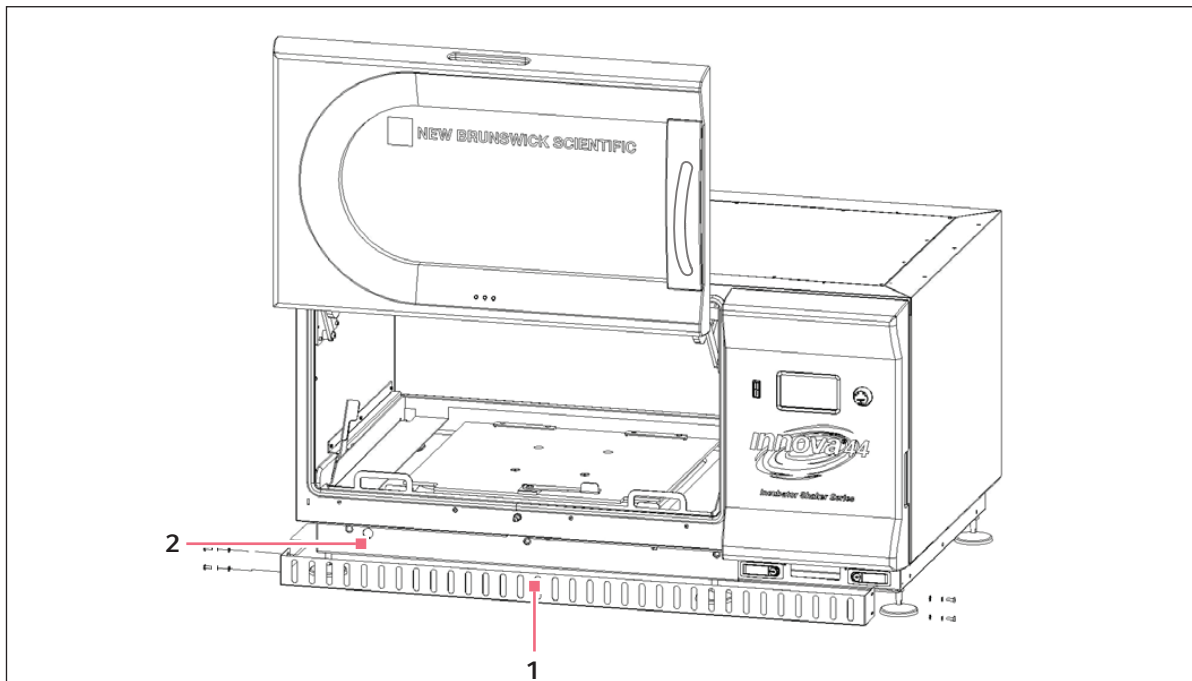

Fig. 8-6: Front grille

1 Front grille**2 Drain hose extends through this cutout**

2. Check the drain hose to be sure it is clamped tightly.
3. Replace the grille and secure it with the 4 thumbscrews that you previously removed.



Never pour water directly under the subplatform. Pour water very slowly into the shallow area beyond the edge of the adapter plate, to protect the bearing housing.

4. Accessing the pan/reservoir from the left, the right or in front of the subplatform, slowly fill the reservoir with no more than 3 L of distilled water.

8.10 Drain the water reservoir

To drain water from the water reservoir/spill pan:

1. Temporarily remove the four thumbscrews that secure the front grille (see Fig. 8-6 on p. 44).
2. Disengage the drain hose, direct it to a container or drain, then unclamp it, allowing the water to gravity drain.
3. Reclamp the hose, tuck it back in place, and replace the grille, securing it with the thumbscrews you previously removed.



The spill pan/water reservoir drain is located in the front, on the left, under the slide-out tray.



The drain hose should be tightly clamped when it is not being used for draining the reservoir. Keep it clamped even if there is no water in the pan.

Getting started

New Brunswick Innova® 44/44R Shaker
English (EN)

9 Operation

9.1 Safety precautions

Before operating the shaker, verify that anyone involved with its operation has been instructed in both general safety practices for laboratories and specific safety practices for this apparatus.

- The user is also responsible for following local guidelines for handling hazardous waste and biohazardous materials that may be generated from the use of this equipment.



WARNING! Personnel injury and equipment damage!

- ▶ This equipment is not explosion-proof and should never be used with flammable substances or used to grow organisms that produce flammable by-products.



CAUTION! Equipment damage!

- ▶ To prevent damage to the shaker and its contents, never run the shaker without a platform.
-

9.2 Opening the door

Open the door by firmly pulling the handle straight out to release the latching mechanism. You can now manually move the door up to the open position, or down to the closed position (make sure it latches closed).

9.3 Start the shaker

To initially start the shaker, close the door and turn the power switch (located on the righthand side of the control panel) to the ON position. The display will come on (first showing only New Brunswick Scientific, then briefly displaying the model number, 44 or 44R, and the stroke, 1 inch or 2 inch, and then quickly moving into the Display screen), and the audible alarm will sound. To mute it, (see *Mute the audible alarm on p. 61*).

When the shaker begins to operate, the LCD display will track the speed as it accelerates to the last entered setpoint. The shaking action may be started or stopped by pressing the Start/Stop button on the front panel.



The shaker will not operate if the door is open. This is indicated by the “door open” symbol appearing in the bottom line of the display (see Fig. 7-3 on p. 33).

Operation

New Brunswick Innova® 44/44R Shaker
English (EN)

9.4 Using the LCD screens**9.4.1 Display screen**

When you turn the power on, this is the first screen to appear after the company title screen. The default display parameters are temperature (°C) and shaking speed (RPM).

You can change the displayed parameters.

To replace a parameter:

1. Using the control knob, highlight the parameter that you wish to replace. For this example, we will replace RPM (see Fig. 9-1 on p. 48).

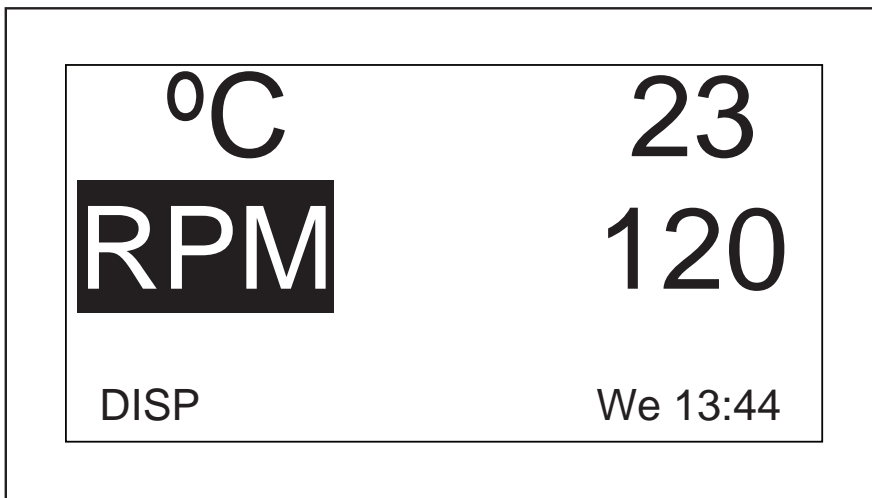

Fig. 9-1: Changing display parameter

2. Click the control knob in. RPM will flash.
3. Turn the knob until the desired parameter appears in the highlighted field. For this example, we will select HRS.
4. Click the knob in to set and save the parameter (see Fig. 9-2 on p. 48).

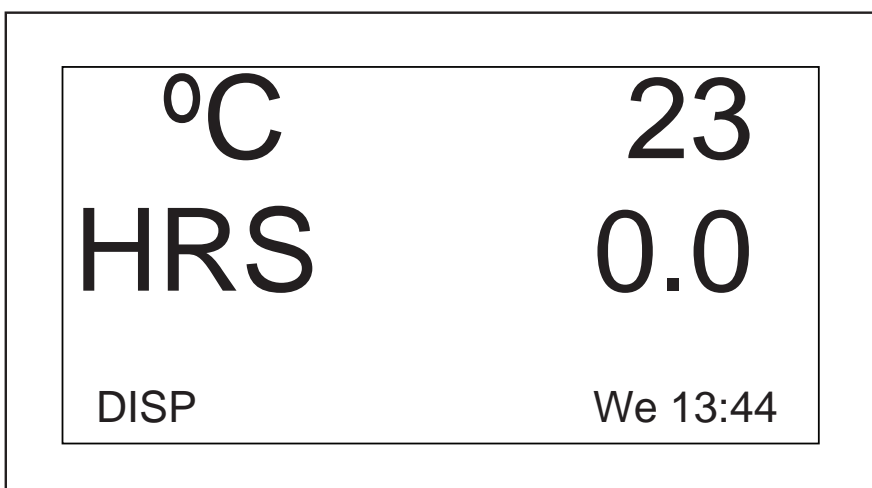

Fig. 9-2: Changed display parameter

i If you highlight an item, change it, but do not save your selection, after a few seconds the screen will revert to its previous setting.

i *UV* (UV Germicidal lamp) and *GRO* (photosynthetic growth lamps) will appear in this screen with the word *NONE* if your shaker is not equipped with these optional features.

You can also use this screen to verify a setpoint, even though the values displayed here are actual (current) values.

To view a setpoint:

1. Use the control knob to highlight the value (in this example, we will view the temperature setpoint, so we will highlight the current °C, which is 23).
2. Click the knob in to display the current setpoint, which will flash.

At this point you can modify the setpoint or click the Knob in again to return to the normal display, which will be the actual temperature.

To modify a setpoint in this screen:

1. Use the control knob to highlight the current value (we will continue to use the temperature as our example, so we will select 23).
2. Click the knob in to display the current setpoint (in this example, 38.5 (see Fig. 9-3 on p. 49)), which will flash.

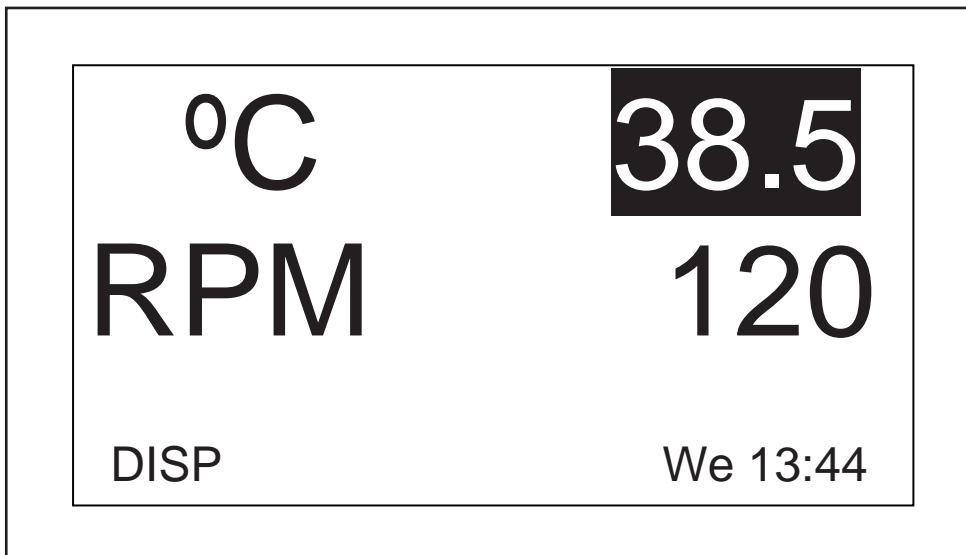

Fig. 9-3: Changing setpoint

3. Turn or spin the knob to reset the setpoint (in this example, turn the knob left to decrease the setpoint to 37.0).

Operation

New Brunswick Innova® 44/44R Shaker
English (EN)

i If you turn the control knob slowly, one click left or right will change the setpoint by an increment of one tenth of a degree Celsius (0.1 °C). If you spin the knob quickly, the value will change by larger increments.

4. Click the knob in to set and save this new setpoint.

i If you highlight an item, change it, but do not save your selection, after a few seconds the screen will revert to its previous setting.

5. The display will automatically return to the actual value.

To move out of this screen and into the next:

1. Use the control knob to highlight *DISP*, then click the knob in.

DISP begins to flash.

2. Turn the knob to the right until the next screen, *Summary (SUMM)*, appears. If you turn too far and enter another screen, just turn the knob back to the left to recapture the *SUMM* screen.

3. Click the knob in to select the screen and to work in it.

9.4.2 Summary screen

In this screen (see Fig. 9-4 on p. 50), you can see both the current *ACTUAL* readings and the *SET* points for shaking speed (*RPM*), chamber temperature (°C), elapsed time in a programmed run (*HRS*) and, if you are using the optional Humidity Monitor, the percentage of relative humidity (*%RH*).

<u>PARAM</u>	<u>ACTUAL</u>	<u>SET</u>
RPM	100	100
°C	45.1	45.0
HRS	0.0	0.0
%RH	50.0	N/A
SUMM	Th 16:18	

Fig. 9-4: Summary screen

i The current day (*Su, Mo, Tu, We, Th, Fr* or *Sa*) and time always remains visible in the lower righthand corner.

The only elements you can modify in this screen are setpoints.

To change setpoints in this screen:

1. Turn the knob until the desired setpoint is highlighted, then click the knob in.
The setpoint will begin to flash.
2. Turn the knob to the right to increase the number, or to the left to decrease it. One click left or right will increase the setpoint by an increment of one (one whole unit or one tenth unit, depending on the parameter). Move the knob more rapidly (you can spin it) to change the value by larger increments.
3. Click the knob in to set and save the new value.



If you highlight an item, change it, but do not save your selection, after a few seconds the screen will revert to its previous setting.

4. Repeat the above steps to change any or all of the other setpoints.

To move out of this screen and into the next:

1. Use the control knob to highlight *SUMM*, then click the knob in.
SUMM begins to flash.
2. Turn the knob to the right until the next screen, *Setup (SET)*, appears. If you turn too far and enter another screen, just turn the knob back to the left to recapture the *SET* screen.
3. Click the knob in to select the screen and to work in it.

9.4.3 Setup screen

Here you can set the day of the week and the time (on a 24-hour clock). This screen also allows you to lock all of your settings from further changes, and to mute or enable the audible alarm.

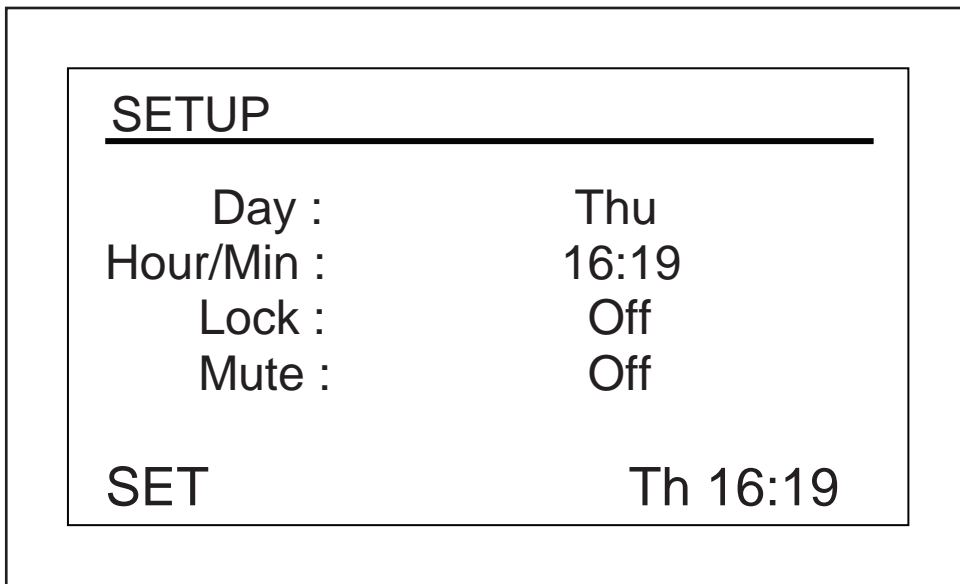

Fig. 9-5: Setup screen

Operation

New Brunswick Innova® 44/44R Shaker
English (EN)

To change the day:

1. Turn the knob to highlight the day (*Thu* in the sample screen, (see Fig. 9-5 on p. 51)), then click inward once.
The day will flash.
2. Turn the knob left or right to select the day of choice: Sun, Mon, Tue, Wed, Thu, Fri or Sat.
3. Click the knob in to set and save your choice.



If you highlight an item, change it, but do not save your selection, after a few seconds the screen will revert to its previous setting.

To change the time (hour/min):

1. Turn the knob to highlight the time (*16:19* in the sample screen, (see Fig. 9-5 on p. 51)) then click inward once.
The time will flash.
2. Turn the knob left or right to change the time. Left moves backward, right moves forward in time. One click right or left changes by one minute; spin the knob quickly to move more rapidly.
3. Click the knob once inward to set and save your choice.

To lock the settings:

1. Turn the knob to highlight *Lock*, then click inward once.
The current status (*Off* in the sample screen, (see Fig. 9-5 on p. 51)) will flash.
2. Turn the knob in either direction; the only other choice is *On*. Click once inward to select and save *On*, or continue turning to return to *Off*.



When you set *Lock* to *On*, a padlock icon (see *Display icons* on p. 35) will appear at the bottom of the screen. This icon will remain on display through all main display screens until you turn the locking function off.

To mute the audible alarm:

1. Turn the knob to highlight *Mute*, then click inward once.
The current status (*Off* in the sample screen, (see Fig. 9-5 on p. 51)) will flash.
2. Turn the knob in either direction; the only other choice is *On*. Click once inward to select and save *On*, or continue turning to return to *Off*.



When you set *Mute* to *On*, the crossed-out speaker icon will appear at the bottom of the screen. This icon will remain on display through all screens until you turn the muting function off.

To move out of this screen and into the next:

1. Use the control knob to highlight *SET*, then click the knob in.
SET begins to flash.

2. Turn the knob to the right until the next screen, *Lamps (LAMP)*, appears. If you turn too far and enter another screen, just turn the Knob back to the left to recapture the *LAMP* screen.
3. Click the knob in to select the screen and to work in it.

9.4.4 Lamps screen

In this screen (see Fig. 9-6 on p. 53), you can turn the chamber light (*Chamber*), the optional UV germicidal (decontamination) lamp (*UV Decont*) and the optional photosynthetic growth lamps (*Growth*) on and off. *On* means the light is always on, and *Off* means the light is always off, unless you add additional programming (see *Program the shaker* on p. 57).

There is an additional mode for the chamber light: *Auto*. In *Auto* mode, the light will go on every time you activate the control knob or open the door. This is the default mode.



The *Lamps* screen, shown below, will always indicate *Chamber* light mode. If the shaker is not equipped with the optional UV germicidal lamp and/or photosynthetic growth lamps, *UV Decont* and/or *Growth* will say *None*.

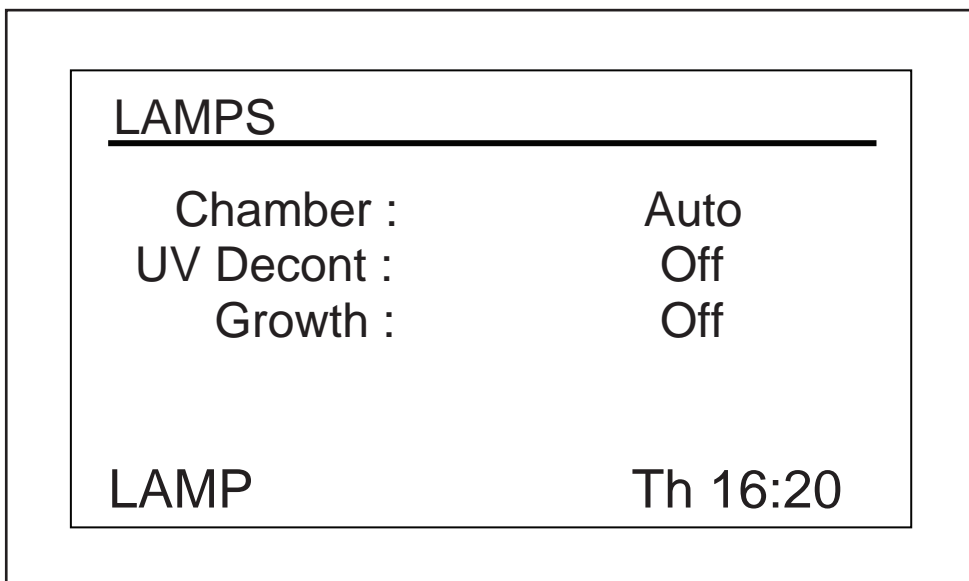

Fig. 9-6: Lamps screen

To change the mode setting for any of the lamps:

1. Turn the control knob to highlight the setting for the lamp of choice, then click the knob in.
 The current setting will flash (in the sample screen, we will use the *Chamber* light as an example (see Fig. 9-6 on p. 53)).
2. Turn the knob left or right until the desired mode setting appears (*Auto* in this example (see Fig. 9-6 on p. 53)).
3. Click the knob in to save the new setting.

Operation

New Brunswick Innova® 44/44R Shaker
English (EN)



If you highlight an item, change it, but do not save your selection, after a few seconds the screen will revert to its previous setting.

To move out of this screen and into the next:

1. Use the control knob to highlight *LAMP*, then click the knob in.
LAMP begins to flash.
2. Turn the knob to the right until the next screen, *RS232 (COMM)*, appears. If you turn too far and enter another screen, just turn the knob back to the left to recapture the *COMM* screen.
3. Click the knob in to select the screen and to work in it.

9.4.5 RS232 Screen

This screen (see Fig. 9-7 on p. 54) is used only if you have connected a personal computer to the RS-232 port (see *Software interfaces on p. 37*). Here you can select the RS-232 port's *Mode* and the *Baud Rate* appropriate to your PC.

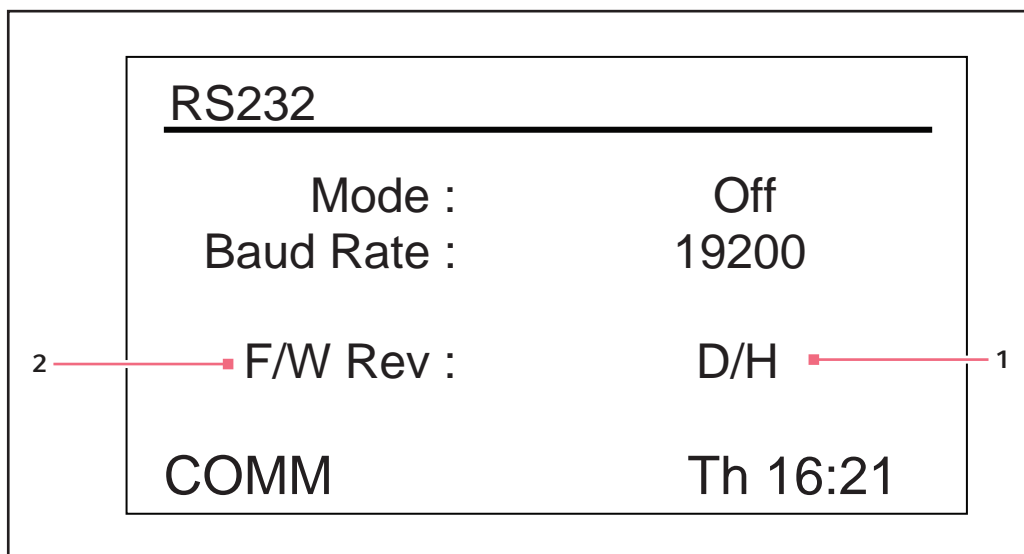

Fig. 9-7: RS232 screen

- 1** In this sample screen, the display is at revision **2** Firmware revision level (this line is for D and the firmware control board at revision H. information only)

To change the communication mode:

1. Turn the control knob to highlight the current setting (*Off* in the sample screen, (see Fig. 9-7 on p. 54)), then click the knob in.
The current setting will flash.

2. Turn the control knob left or right until the desired mode setting appears (see *Turn the control knob to highlight the current setting (Off in the sample screen, (see Fig. 9-7 on p. 54)), then click the knob in. on p. 54*).
3. Click the control knob inward once to save the new setting.



If you highlight an item, change it, but do not save your selection, after a few seconds the screen will revert to its previous setting.

Tab. 9-1: Communication Mode

Mode	Application
Off	The RS-232 port is not open to communication in either direction
Slave	The shaker can be fully controlled from the computer
Talk	The shaker sends current value reports to the computer once per minute
Monit [Monitor]	The shaker responds only to report requests (see <i>Report request commands on p. 83</i>)

To change the baud rate:

1. Turn the control knob to highlight the current setting (19200 in the sample screen, (see Fig. 9-7 on p. 54)), then click the knob inward once.
The current setting will flash.
2. Turn the control knob left or right until the desired setting appears: 9600, 19200 or 38400. The setting you choose should match the baud rate of your computer.
3. Click the control knob inward once to save the new setting.

To move out of this screen and into the next:

1. Use the control knob to highlight *COMM*, then click the knob in.
COMM begins to flash.
2. Turn the knob to the right until the next screen, *Calibrate (CAL)*, appears. If you turn too far and enter another screen, just turn the knob back to the left to recapture the *CAL* screen.
3. Click the knob in to select the screen and to work in it.

Operation

New Brunswick Innova® 44/44R Shaker
English (EN)

9.4.6 Calibrate screen

Use this screen (see Fig. 9-8 on p. 56) to create a temperature offset and to calibrate the shaking speed. For details, (see *Temperature offset calibration on p. 62*) and (see *Using Calspeed on p. 63*).

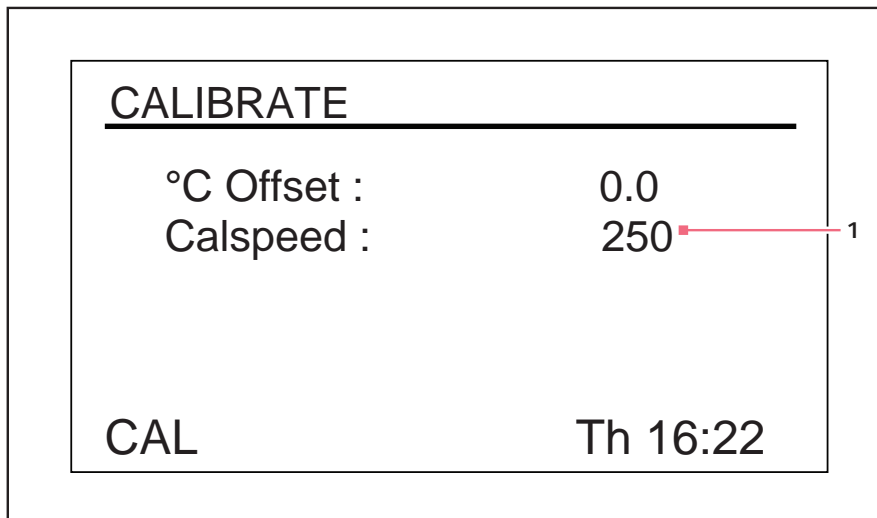

Fig. 9-8: Calibrate screen

1 Indicated RPM value**9.4.7 Programs screen**

Use this screen (see Fig. 9-9 on p. 56) to set as many as 4 operating programs for the shaker. Each program can have as many as 15 steps. For complete details, (see *Program the shaker on p. 57*).

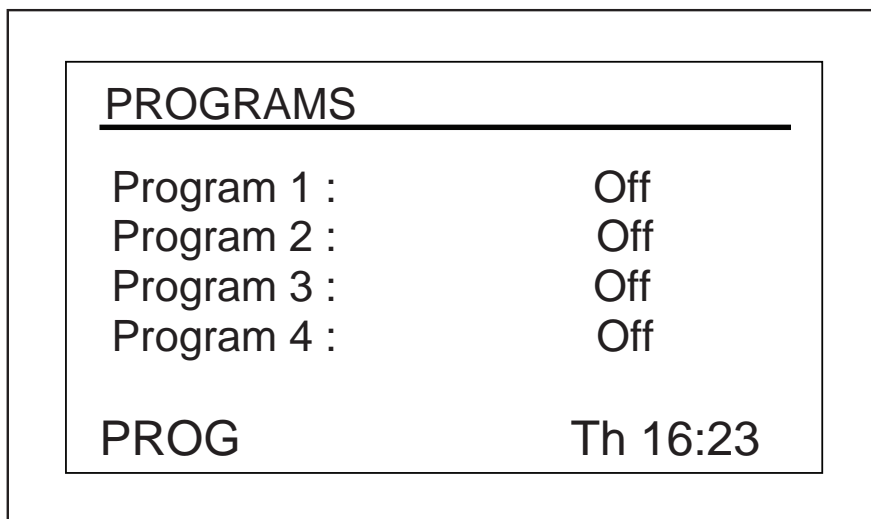

Fig. 9-9: Programs screen

9.5 Program the shaker

9.5.1 Timer only

By setting an *HRS* setpoint in the *DISP* or *SUMM* screen, the shaker may be set to automatically stop after a preset time period of 0.1 to 99.9 hours.

If the time is set to 0.0, the shaker will operate continuously until either the door is opened or the Start/Stop button is pushed.

9.5.2 Programmed steps

The resident software for the Innova 44/44R can store up to four programs, each having as many as 15 steps. Each step can be programmed in one-minute increments, for total periods of one minute up to 99 hours 59 minutes each.

To enter the programming mode, use the control knob to select the *PROG* screen (see Fig. 9-10 on p. 57). At this point, you can *Run* a program, *Edit* a program, generate a *New* program or turn a program *Off*. *Off* is the default mode.

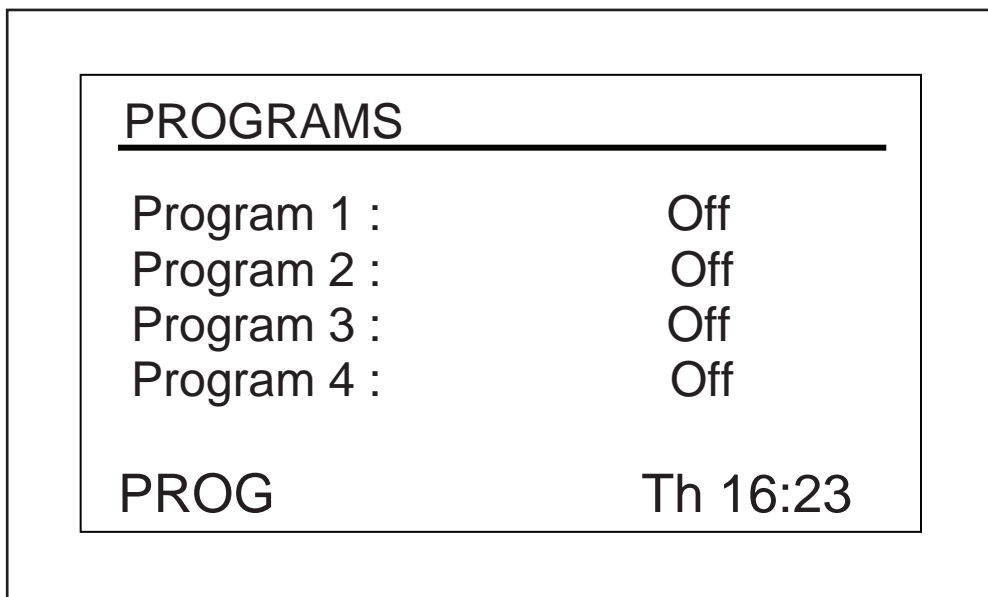

Fig. 9-10: Programs screen

9.5.3 Create a program

To write a new program:

1. Use the control knob to highlight the mode of Program 1 (in our sample screen, (see Fig. 9-10 on p. 57), it is *Off*), then click the knob in.

The selected field begins to flash.

Operation

New Brunswick Innova® 44/44R Shaker
English (EN)

- Turn the knob until the field says *New*. Click the knob in to select this mode. The screen for Program 1 - Step 1 will open (see Fig. 9-11 on p. 58):

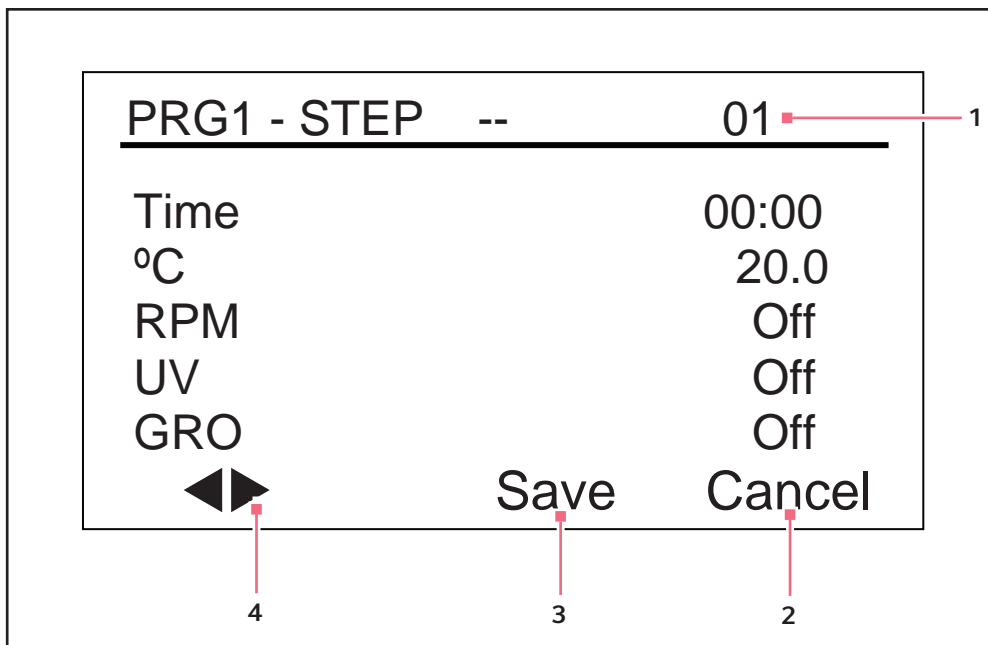

Fig. 9-11: Program 1, Step 1

- | | |
|--|---|
| 1 Step Number | 3 Do not use until programming is complete |
| 2 Use to leave programming mode without saving any new settings | 4 Use these arrows to scroll through steps |



If your shaker is not equipped with these optional features, *UV* and *GRO* will appear with the word *Off* in this screen but will not be programmable.

- Turn the knob to highlight the time setting (00:00 in the sample screen, (see Fig. 9-12 on p. 59)), then click the knob in. The field will flash.
- Turn the knob until the desired running duration for this step (from 00:01, which means one minute, to 99:59) appears, then click the knob in to save the setting. We will set *Step 1* time to *8 hours* for this example (see Fig. 9-12 on p. 59).
- Turn the knob to highlight the °C temperature setting (20.0 in the sample screen, (see Fig. 9-11 on p. 58)), then click the knob in. The field will flash.
- To set the temperature desired (°C from 4.0 to 80.0) for the time period you have set, turn the knob (left to decrease, right to increase). When the desired value appears, click the knob in to save the setting. We will set *Step 1* temperature to *37.0 °C* (see Fig. 9-12 on p. 59).
- Turn the knob to highlight the *RPM* setting (*Off* in the sample screen above), then click the knob in. The field will flash.
- Turn the knob to select the desired shaking speed (25 to 400 RPM) for this time period, then click the knob in to save the setting. We will set *Step 1* speed to *150 RPM* (see Fig. 9-12 on p. 59).

i When stacking three shakers, all shaker loads must be balanced. These shakers operate best at maximum speed with a load of 15.5 (± 1.4) kg or 34 (± 3) lb, which includes all platforms, clamps, and filled glassware.

For three stacked 2 in stroke shakers, maximum operating speed must be limited to 250 rpm.

9. If you do not have the optional *UV* lamp, skip this step. If you have the UV lamp (default setting is *Off*) and you wish to have it on during the time period you have set, use the control knob to select the field, click the knob to select the field (it will flash), turn the knob to select *On*, then click the knob in to save the setting. In our sample *Step 1* (see Fig. 9-12 on p. 59), however, *UV* remains *Off*.
10. If you do not have the optional *GRO* lamps, skip this step. If you have the photosynthetic lamps (default setting is *Off*) and you wish to have them on during the time period you have set, use the control knob to select the field, click the knob to select the field (it will flash), turn the knob to select *On*, then click the knob in to save the setting. In our sample *Step 1* (see Fig. 9-12 on p. 59), however, *GRO* remains *Off*.

i DO NOT select *Save* yet!

11. To program *Step 2* (see Fig. 9-12 on p. 59): use the control knob to highlight the arrows at the bottom left of the screen. Click the knob to make the arrows flash, then turn the knob to the right until *Step 2* appears. Click the knob in to work in this screen, and repeat Steps 3 – 10. Whatever step is shown on the right-hand side of the display is settable ((see Fig. 9-12 on p. 59), it is *Step 2*). To scroll between steps, select the arrows (bottom left), then turn the control knob clockwise or counterclockwise, then select the desired step.

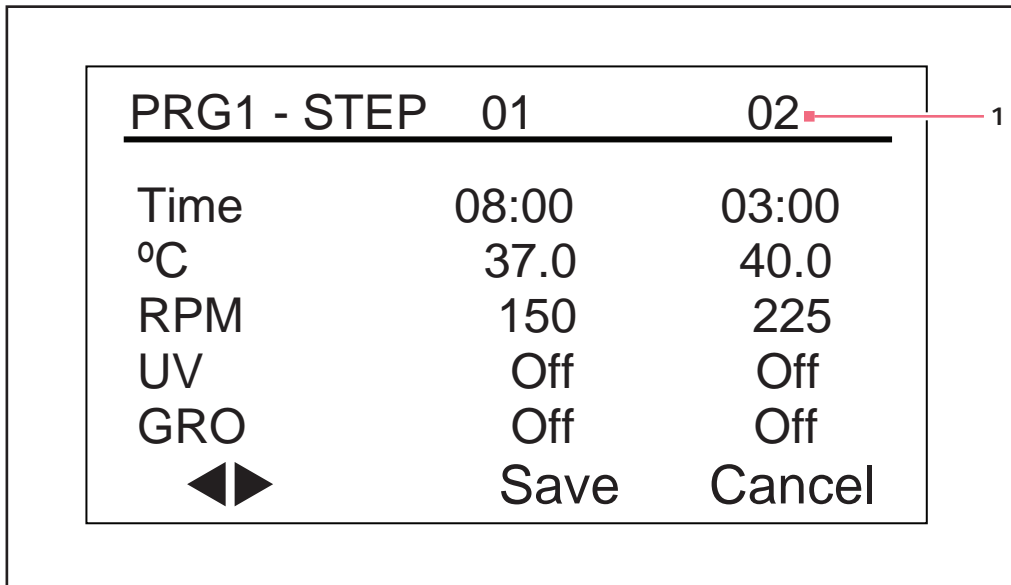

Fig. 9-12: Program 1, Step 2

1 Step number

i The time entered for each step is for that step only; it is not cumulative (i.e. the elapsed time from the start of the program).

12. Continue to program as many as 15 steps in the same manner. For our sample program, we have only 3 steps (see Fig. 9-13 on p. 60).

PRG1 - STEP		02	03
Time		03:00	12:00
°C		40.0	4.0
RPM		225	0
UV		Off	Off
GRO		Off	Off
	◀▶	Save	Cancel

Fig. 9-13: Program 1, Step 3

1 Step Number

The 3-step program we have illustrated is designed to start incubating cultures at 37 °C and hold that temperature for 8 hours, shaking at 150 RPM. After 8 hours, Step 2 engages, increasing the temperature setpoint to 40 °C for a temperature induction, holding that temperature for 3 hours and increasing the shaking speed to 225 RPM. After this interval, the temperature will be cooled to 4 °C and held at that temperature for 12 hours; no shaking will occur during this period, as the speed is set to 0 RPM.

Please note that temperature reductions, even at temperatures above ambient (going from 40 °C to 30 °C, for example), require refrigeration to be effective.



When the last step of a program is completed, the Innova 44/44R will continue operating according to the parameters of the final step programmed, until the user intervenes.



If you wish the shaker contents to experience different conditions (e.g., a different shaking speed or no shaking at all, and/or return to ambient temperature), set those parameters as the last step in your program.

To save the entire program:

1. Once all your steps are set, use the control knob to highlight *Save* at the bottom of the screen, then click the knob in. The field will flash.
2. Click the knob in again to save the program. The display will read *Process Running – Saving Profile* for a few seconds, then return to the main Programs (*PROG*) screen.

If you wish, you can set Programs 2, 3 and 4 and save them in the same manner.

9.5.4 Edit a program

Use the *Edit* function to open a program you have already created and saved, in order to modify your settings following the same procedures.

9.5.5 Run a program

Use the *Run* function to turn a specific program on. Naturally, only one program can run at a time. When you change the mode to *Run*, the screen will show the *Run* icon:

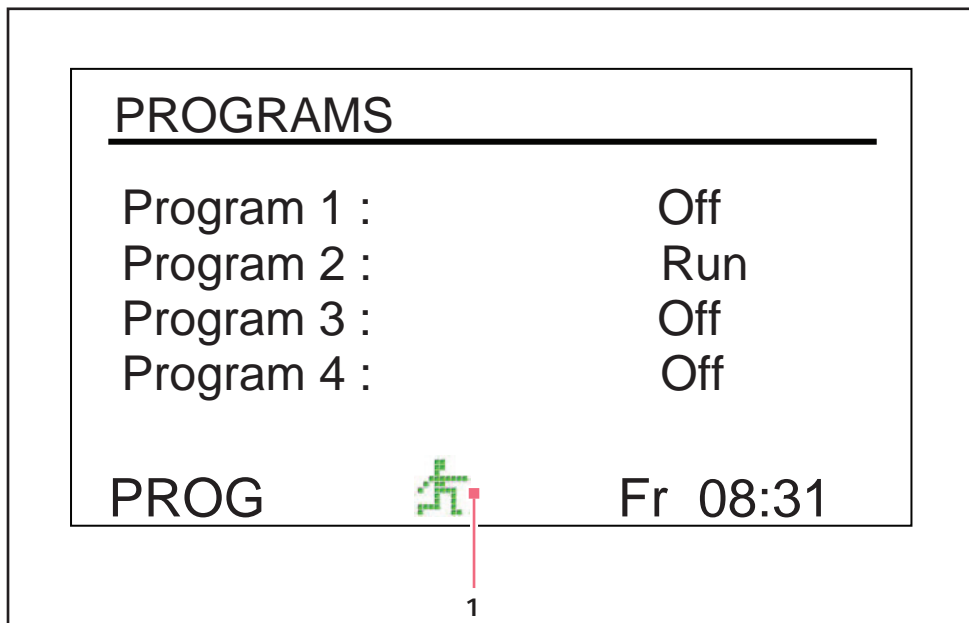

Fig. 9-14: Programs screen, running

1 Run icon

To stop a program:

You can abort a run any time by changing the program's function to *Off*.

9.6 Mute the audible alarm

The Innova 44/44R shakers have an audible alarm that is activated under predetermined conditions. It may be muted in the following way:

1. Turn the Control Knob until the **SET** screen is highlighted on the display. Click the Knob in to work in this screen.
2. Turn the Knob to highlight the **Mute** mode (**On**), then click the Knob in. The field will flash.

Operation

New Brunswick Innova® 44/44R Shaker
English (EN)

- Turn the Knob to change the setting to **Off**, then click the Knob to save this selection.

To reactivate the audible alarm at any time, repeat steps 1 – 3, reversing “off” and “on”.

9.7 Temperature offset calibration

The temperature probe and the temperature controller are calibrated together at the factory. The temperature probe measures the temperature of the air at the probe’s location, near the return vent. The controller uses the probe input to adjust air temperature, up or down, to match the temperature setpoint.

Depending on various conditions within the chamber, such as flask placement and size, the heat produced by growing organisms, heat losses due to liquid evaporation from flasks, etc., the display temperature may differ from temperatures within the flasks themselves. You can calculate the correction value for this offset and program the shaker to display a corrected temperature.

9.7.1 Calculate the offset value

If you wish to have the temperature display (indicated temperature) match the temperature at a given point, or match the average of a series of points within the chamber (actual temperature), proceed as follows:

- Let the unit equilibrate at or near the desired temperature, then record the indicated temperature.
- Now record the actual temperature.
- Calculate the temperature correction value using this formula: $actual\ temperature - indicated\ temperature = temperature\ offset\ value$.
- To set the temperature calibration offset, follow the procedure outlined in the next paragraph below.

9.7.2 Set the offset

To set the temperature calibration offset:

- Use the control knob to enter the *CAL* screen (see Fig. 9-15 on p. 63).
- Turn the control knob to highlight the current setting (*0.0* in the sample screen above), then click the knob in. The current setting will flash.
- Turn the knob (left for negative settings or right for positive settings) to display the desired setting. As you turn the knob, each click represents one tenth of a degree Celsius (0.1 °C).
- When you reach the desired setting, click the control knob in to save the new value.
- When the temperature offset is set to any value other than 0, the asterisk icon will appear next to °C in the *DISP* and *SUMM* screens.



If you highlight an item, change it, but do not save your selection, after a few seconds the screen will revert to its previous setting.

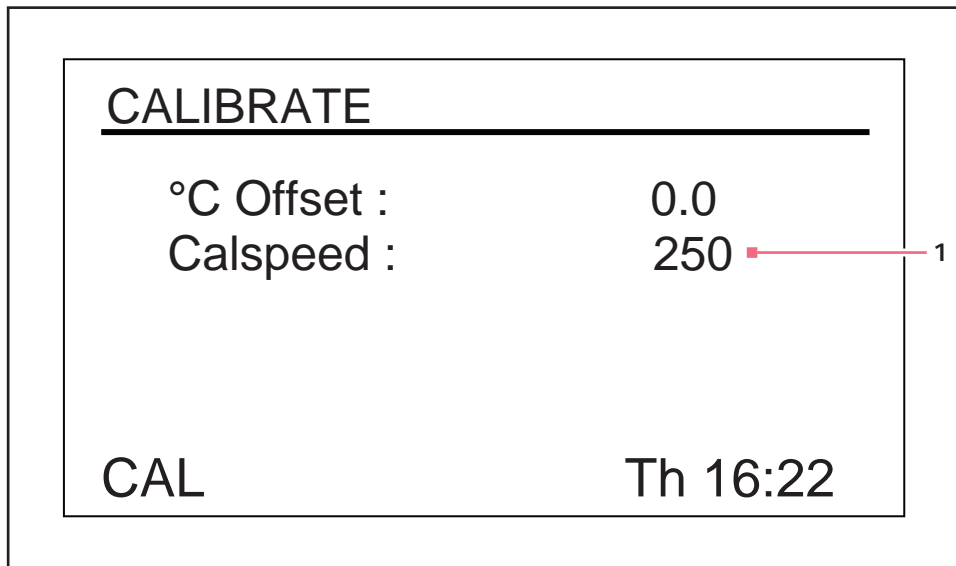

Fig. 9-15: Calibrate screen

1 Indicated RPM value

9.8 Using Calspeed

The **Calspeed** function, which is set in the **CAL** screen (see Fig. 9-15 on p. 63), is used to calibrate the speed of the shaking mechanism. Calibrated at the factory, speed does not need to be recalibrated until a major operating component (e.g. drive belt) is changed.



Prior to engaging the **Calspeed** function, make sure that the platform is properly secured to the subplatform, and any flasks present are secured. Run the unit at approximately 250 RPM to ensure stable operation prior to calibration.

When the shaker is running, the **CAL** screen shows the indicated RPM value. If you wish to calibrate the speed, set the speed to a value that can be measured, a setpoint of 250 RPM works well. The use of a strobe is recommended for accuracy. If, after measuring the actual speed, you wish to adjust the indicated value:

1. Click the Control Knob in.
2. Set the new value.
3. Click the Knob in again to save the setting.
4. Turn the shaker OFF, wait a few seconds, then turn the shaker back ON.

Operation

New Brunswick Innova® 44/44R Shaker
English (EN)

9.9 Power interruption

In the event of a power failure, the Innova 44/44R Shakers are equipped with an automatic restart function. The shaker's non-volatile memory retains all stored information.

If the shaker was in operation prior to the power interruption, the shaker will begin to operate at its last entered setpoints. The alarm/POWER display will flash, indicating that a power interruption has occurred. Turn the Control Knob in any direction to acknowledge the visual alarm. The flashing will stop.

9.10 Slide-out platform

The Innova 44/44R is equipped with a slide out platform mechanism as a standard feature. This allows you to easily slide the platform out of the shaker for easy access to the platform without the need for tools.

To operate the platform slide-out mechanism:

1. Make sure platform has stopped moving.
2. Rotate cam lever located on the subplatform (see Fig. 9-16 on p. 65) 180 ° clockwise. It should be pointing to the left.
3. Pull both side levers (see Fig. 9-16 on p. 65) down. This will disengage the platform from the subplatform.
4. Pull both handles on the slide-out mechanism (see Fig. 9-16 on p. 65) toward you. This will move the platform to an easily accessible position.

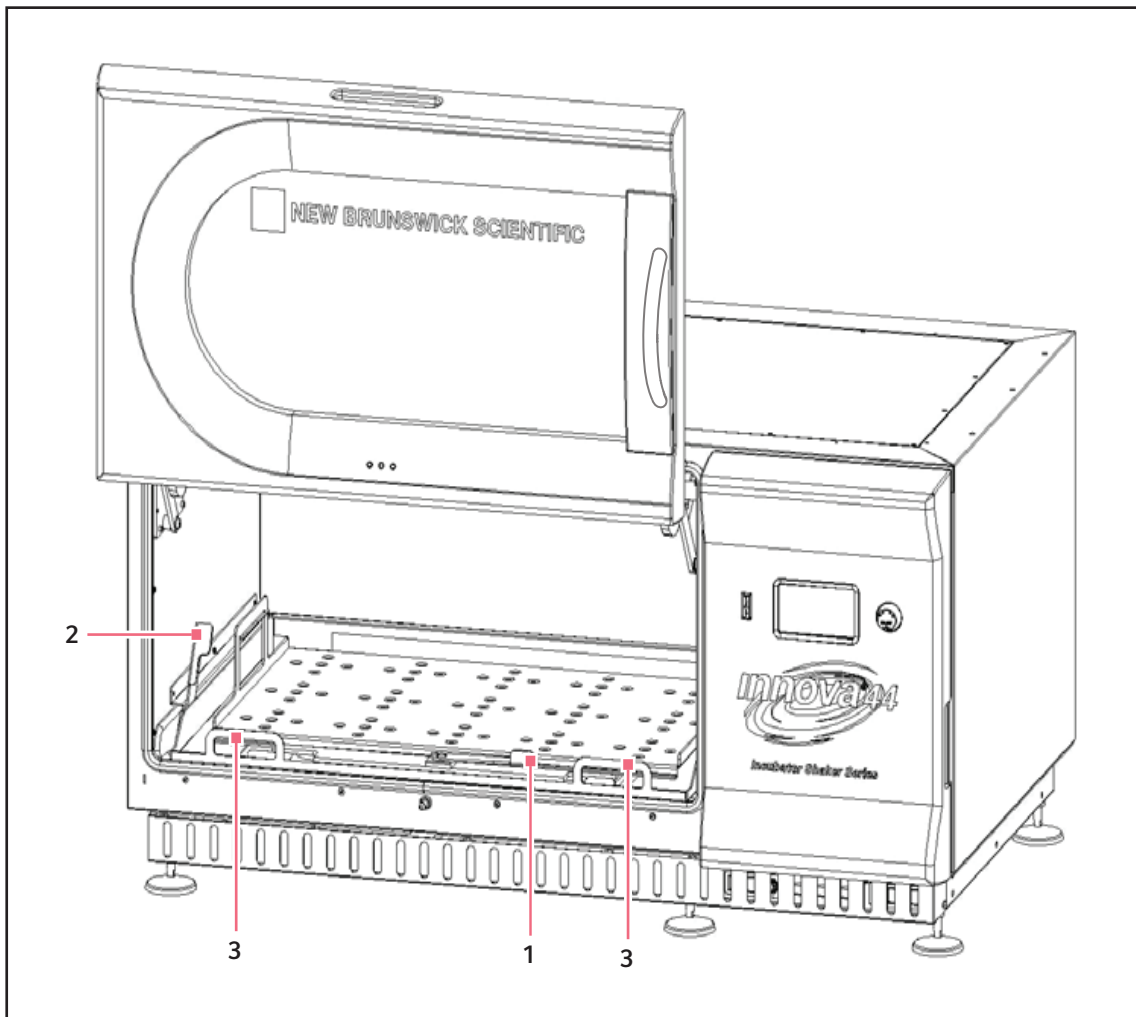

Fig. 9-16: Disengaging Slide-Out Platform

1 Subplatform cam lever

3 Slide-out tray handles

2 Side lever

5. To re-insert the platform, reverse this process. Make sure the two slots in the back of the platform are inserted under blocks of subplatform in the back.



Make sure that you have rotated the front cam lever counter-clockwise to lock the platform in position.

Operation

New Brunswick Innova® 44/44R Shaker
English (EN)

10 Troubleshooting

Problem	Cause	Solution
Shaker does not run.	<ul style="list-style-type: none"> • No power. • Display is not on. • Device is not connected to mains/power supply and/or mains/power switch is switched off. 	<ol style="list-style-type: none"> 1. Connect the device to mains/power supply. 2. Press the mains/power switch.
	<ul style="list-style-type: none"> • Door is open. Look for icon on display. 	<ul style="list-style-type: none"> ▶ Close door firmly, making sure latches are engaged.
	<ul style="list-style-type: none"> • Mains/power switch is not working. • Door is closed but Door open icon is on display: Door magnet is not adjusted correctly. • Defective main board. • Defective display controller board. • Jammed shaking mechanism. • Defective motor. • Drive belt out of alignment or worn. 	<ul style="list-style-type: none"> ▶ Contact your local Eppendorf service partner.
	<ul style="list-style-type: none"> • Fuse(s) burned out. 	<ul style="list-style-type: none"> ▶ Contact your local Eppendorf service partner.
	<ul style="list-style-type: none"> • Shaking speed has been set to zero by program running or by computer interface. 	<ol style="list-style-type: none"> 1. Check program. 2. Reset speed.
	<ul style="list-style-type: none"> • Tilt switch has been triggered. • Alarm condition tilt will be indicated and RPM will be off. 	<ol style="list-style-type: none"> 1. Ensure that the load is evenly distributed and the shaker is level on a solid surface. 2. Press mains/power switch, to restart the device.
Shaker runs slowly and/or no speed indication.	<ul style="list-style-type: none"> • Fuse(s) burned out. 	<ul style="list-style-type: none"> ▶ Contact your local Eppendorf service partner.
	<ul style="list-style-type: none"> • Incorrect speed calibration 	<ul style="list-style-type: none"> ▶ Recalibrate speed. See chapter <i>Using Calspeed</i> (see p. 63).
	<ul style="list-style-type: none"> • Defective main board. • Defective motor. • Drive belt out of alignment or worn. 	<ul style="list-style-type: none"> ▶ Contact your local Eppendorf service partner.
Shaker does not run at set speed.	<ul style="list-style-type: none"> • Shaker speed has been changed by RS-232 command/computer interface. 	<ol style="list-style-type: none"> 1. Disconnect from RS-232 interface. 2. Reset speed.
	<ul style="list-style-type: none"> • Shaker is overloaded. 	<ol style="list-style-type: none"> 1. Remove some contents. 2. Balance load.
	<ul style="list-style-type: none"> • Defective motor. • Drive belt out of alignment or worn. 	<ul style="list-style-type: none"> ▶ Contact your local Eppendorf service partner.
Operating noise.	<ul style="list-style-type: none"> • Load is out of balance. 	<ol style="list-style-type: none"> 1. Unload all contents. 2. Reload platform and balance load.
	<ul style="list-style-type: none"> • Loose component(s) in slide-out platform, sub-platform, and/or drive assembly. 	<ul style="list-style-type: none"> ▶ Contact your local Eppendorf service partner.

Troubleshooting

New Brunswick Innova® 44/44R Shaker
English (EN)

Problem	Cause	Solution
Device does not reach set temperature.	<ul style="list-style-type: none"> • Shaker running in <i>Program</i> mode. 	<ol style="list-style-type: none"> 1. Check program parameters. 2. Reset temperature, if necessary.
	<ul style="list-style-type: none"> • Temperature set value changed by RS-232/computer interface command. 	<ol style="list-style-type: none"> 1. Disconnect from RS-232 interface. 2. Reset temperature.
	<ul style="list-style-type: none"> • Compressor over-pressure switch activated. • Chamber fans not working. • Door is not completely closed (even though Open Door icon may not be on display). • Sealing between the service drawer and the chamber is damaged. • Defective heater. • Defective refrigeration system. 	<ul style="list-style-type: none"> ▶ Contact your local Eppendorf service partner.
	<ul style="list-style-type: none"> • Ambient temperature is too high or too low. 	<ul style="list-style-type: none"> ▶ Cool or heat the room. See ambient conditions in chapter <i>Preparing the location</i>(see p. 19).
	<ul style="list-style-type: none"> • Firmware revision does not match the service drawer revision. 	<ul style="list-style-type: none"> ▶ Contact your local Eppendorf service partner.
Incorrect temperature indication.	<ul style="list-style-type: none"> • Temperature offset has been programmed. 	<ol style="list-style-type: none"> 1. Check offset value. 2. Reset offset value.
	<ul style="list-style-type: none"> • Defective temperature probe or broken contact. • Defective PCB mainboard. 	<ul style="list-style-type: none"> ▶ Contact your local Eppendorf service partner.
Incorrect relative humidity indication.	<ul style="list-style-type: none"> • Defective humidity probe or broken contact. • Defective PCB mainboard. 	<ul style="list-style-type: none"> ▶ Contact your local Eppendorf service partner.
Photosynthetic light/UV light does not work.	<ul style="list-style-type: none"> • Lamp has been turned off by RS-232 command/computer interface. 	<ol style="list-style-type: none"> 1. Disconnect from RS-232 interface. 2. Turn on lamp.
	<ul style="list-style-type: none"> • Shaker is running in program mode. The program turns off the light. 	<ol style="list-style-type: none"> 1. Check program. 2. Turn on lamp, if necessary.
	<ul style="list-style-type: none"> • Bulb is burned out. • Fuse is burned out. 	<ul style="list-style-type: none"> ▶ Contact your local Eppendorf service partner.
	<ul style="list-style-type: none"> • Ballast voltage is wrong. • Incorrect cable connections. 	<ul style="list-style-type: none"> ▶ Contact your local Eppendorf service partner.
Door does not stay in the fully open position.	<ul style="list-style-type: none"> • Door tension is too low. 	<ul style="list-style-type: none"> ▶ Contact your local Eppendorf service partner.

11 Maintenance

11.1 Biohazard decontamination

It is the responsibility of the user to carry out appropriate decontamination procedures if hazardous material is spilled on or inside the equipment. Before using any cleaning or decontamination method other than those suggested by the manufacturer, users should check with Eppendorf that the proposed method would not damage the equipment.

Commercially available household bleach solutions, when diluted at a 1:10 ratio, are effective in routine decontamination of the instrument. The method for decontaminating a spill depends upon the nature of the spill.

Spills involving fresh cultures or samples known to have low concentrations of biomass should be flooded with decontamination solution and soaked for 5 minutes before cleanup. Spills involving samples with high concentrations of biomass, or involving organic matter, or occurring in areas warmer than room ambient temperature, should be exposed to decontamination solution for at least one hour before cleanup.



WARNING! Personnel injury!

- ▶ Personnel involved in the cleanup of any spill should wear gloves, safety glasses, and a laboratory coat or gown during the cleanup process. Respiratory protection should be considered for spills where aerosolization is suspected.
-

11.2 Routine maintenance

No routine maintenance schedule is required for the Innova 44 and 44R.



WARNING! Personnel injury and equipment damage!

- ▶ When cleaning the unit, always turn off the shaker and disconnect the power cord from the power supply.
-

To ensure that your shaker retains its attractive appearance, an occasional cleaning, using a cloth with conventional household (non-abrasive) cleaner is recommended (see *Cleaning external and internal surfaces on p. 70*).

We recommend you occasionally wipe down the shaker with a non-abrasive household cleaner.

We also suggest that the area around the shaker be vacuumed or swept to remove dust and other debris, ensuring proper air flow in and around the shaker.

Maintenance

New Brunswick Innova® 44/44R Shaker
English (EN)

11.3 Cleaning external and internal surfaces

**WARNING! Personnel injury and equipment damage!**

- ▶ When cleaning the unit, always turn off the shaker and disconnect the power cord from the power supply.
-

The unit may be cleaned using a damp cloth or any standard household or laboratory cleaner to wipe down its outer surfaces. Do not use abrasive or corrosive compounds to clean this instrument, as they may damage the unit.

12 Technical data

12.1 Specifications

These specifications assume a maximum load of 15.5 kg (34 lb), including platform, clamps, glassware and contents.

Alarms	Visible and audible warning indication when: <ul style="list-style-type: none"> • Speed deviates more than 5 rpm from setpoints • Temperature deviates more than 1 °C from setpoints • Timer has expired Audible alarm can be muted		
LCD display	<ul style="list-style-type: none"> • 240 x 128 backlit 		
RS-232	<ul style="list-style-type: none"> • Remote control • Remote monitoring • Remote data logging 		
Setpoint retention	<ul style="list-style-type: none"> • All setpoints and operating status are retained in non-volatile memory 		
Automatic restart	<ul style="list-style-type: none"> • Automatic restart after power is restored • Restart indicated by flashing display 		
Stacking	<ul style="list-style-type: none"> • Up to 3 units may be stacked • Second and third units require stacking kit(s) 		
Drive	<ul style="list-style-type: none"> • Triple-eccentric counterbalanced drive • 9 permanently lubricated ball bearings 		
Drive motor	<ul style="list-style-type: none"> • Solid-state brushless DC motor 		
Safety	<ul style="list-style-type: none"> • <i>Drive interrupt</i> shuts off power to shaker when door opens • Acceleration/deceleration circuit prevents sudden starts and stops, minimizing both splashing and mechanical damage • Independent mechanical sensing switch shuts the motor off in unbalanced condition 		
Electrical requirements	100 V, 50Hz 100 V, 60 Hz 120 V, 60 Hz 230 V, 50 Hz	44: 800 VA per shaker 44R: 1500 VA per shaker	
ETL regulatory standards	UL 61010A-1, CAN/CSA-C22.2 No. 1010.1 UL 61010A-2-010, CAN/CSA-C22.2 No. 1010.2.010		
CE regulatory standards	!Invalid cross reference to: D-NBS-007910.1		
Chamber dimensions	Width	Depth	Height
	91 cm (36 in)	66 cm (26 in)	46 cm (18 in) from top of platform
Chamber door	<ul style="list-style-type: none"> • Door glides out and up 		

Technical data

New Brunswick Innova® 44/44R Shaker
English (EN)

Platform	<ul style="list-style-type: none"> Aluminum 46 × 76 cm (18 × 30 in) Select universal or dedicated styles <p>PLEASE NOTE: Innova 44 and 44R platforms are NOT interchangeable with platforms from other New Brunswick shakers.</p>
Altitude Limit	<ul style="list-style-type: none"> 2000 meters

12.1.1 Shaking ¹

Speed	<ul style="list-style-type: none"> 25 – 400 rpm with 2.5 cm (1 in) orbit 25 – 300 rpm with 5.1 cm (2 in) orbit or with 2 units stacked 25 – 250 rpm for 3 units stacked
Control accuracy	<ul style="list-style-type: none"> ±1 rpm
Indication	<ul style="list-style-type: none"> Displayed in 1 rpm increments
Stroke/orbit	<ul style="list-style-type: none"> 2.5 cm (1 in) 5.1 cm (2 in)

¹ Use of baffled flasks will significantly reduce maximum speed for any shaker

12.1.2 Temperature ²

Range (44)	<ul style="list-style-type: none"> 5 °C above ambient temperature to 80 °C
Range (44R)	<ul style="list-style-type: none"> 20 °C below ambient temperature (minimum 4 °C) to 80 °C
Control accuracy	<ul style="list-style-type: none"> ±0.1 °C from 30 – 40 °C ±0.5 °C over the remaining range
Indication	<ul style="list-style-type: none"> Displayed in 0.1 °C increments
Heater	<ul style="list-style-type: none"> Long-life Low-watt density resistance-type High temperature thermostat

² Depending on ambient factors, such as relative humidity, and options installed

12.1.3 Unit dimensions ³

	Single unit	2 units	3 units
Width	135 cm (53 in)	135 cm (53 in)	135 cm (53 in)
Depth	84 cm (33 in)	84 cm (33 in)	84 cm (33 in)
Height	66 cm (26 in)	132 cm (52 in)	198 cm (78 in)

³ Add 53 cm (21 in) to height and 15.2 cm (6 in) to depth for door clearance

12.1.4 Gross weight

44	238 kg (525 lb)
44R	259 kg (570 lb)
Short base	16.4 kg (36 lb)
Medium base	40.9 kg (90 lb)
Tall base	57.3 kg (126 lb)

Technical data

New Brunswick Innova® 44/44R Shaker
English (EN)

13 Ordering information

13.1 Replacement parts

Order no. (International)	Description
S2116-3051P	Flask clamp screws 10-24 × 5/16 in 25 pieces
M1289-0800	Test tube rack screws 10-24 × 1/2 in 10 flat washers, 10 lock washers
P0300-0470	Chamber light bulb 2 pieces
P0300-0221	Photosynthetic light bulb 1 piece

13.2 Accessories

When ordering accessories, you may be asked to provide the model number and serial number of your shaker. This information is on the electrical specification plate, located on the rear panel of the unit.

13.2.1 Replacement clamp hardware kits

Eppendorf flask clamps come complete with mounting screws. Additional screws are available separately in packs of 25 (Part number S2116-3051P).

Ordering information

New Brunswick Innova® 44/44R Shaker
English (EN)

13.2.2 Test tube racks and other accessories

Accessory Description		Part Number	Platform Capacity
Adjustable angle Test Tube Rack for tubes 8 mm – 11 mm diameter	80 tube capacity	M1289-0100	7
	60 tube capacity	M1289-0010	9
	48 tube capacity	M1289-0001	9
Adjustable angle Test Tube Rack for tubes 12 mm – 15 mm diameter	60 tube capacity	M1289-0200	7
	44 tube capacity	M1289-0020	9
	34 tube capacity	M1289-0002	9
Adjustable angle Test Tube Rack for tubes 15 mm – 18 mm diameter	42 tube capacity	M1289-0300	7
	31 tube capacity	M1289-0030	9
	24 tube capacity	M1289-0003	9
Adjustable angle Test Tube Rack for tubes 18 mm – 21 mm diameter	30 tube capacity	M1289-0400	7
	23 tube capacity	M1289-0040	9
	18 tube capacity	M1289-0004	9
Adjustable angle Test Tube Rack for tubes 22 mm – 26 mm diameter	22 tube capacity	M1289-0500	7
	16 tube capacity	M1289-0050	9
	13 tube capacity	M1289-0005	9
Adjustable angle Test Tube Rack for tubes 26 mm – 30 mm diameter	20 tube capacity	M1289-0600	7
	16 tube capacity	M1289-0060	9
	12 tube capacity	M1289-0006	9
Microplate holder rack (stacked)	3 deep well or 9 standard	M1289-0700	16
Microplate holder rack (single layer)	5 deep well or standard	TTR-221	4
Angled Test Tube Rack Holder ¹ for user-supplied test tube racks that are 10 mm – 13 mm (4 in – 5 in) wide and up to 38 mm (15 in) long.		TTR-210	4
Angled Test Tube Rack Spacer Bar ¹ for use with TTR-210 to accommodate test tubes racks that are less than 13 mm (5 in) wide.		TTR-215	NA

¹ Universal Platform Required

14 Transport, storage and disposal

14.1 Transport and storage

When transporting or storing the device, always use the original packaging material.

14.2 Disposal

In case the product is to be disposed of, the relevant legal regulations are to be observed.

Information on the disposal of electrical and electronic devices in the European Community:

Within the European Community, the disposal of electrical devices is regulated by national regulations based on EU Directive 2002/96/EC pertaining to waste electrical and electronic equipment (WEEE).

According to these regulations, any devices supplied after August 13, 2005, in the business-to-business sphere, to which this product is assigned, may no longer be disposed of in municipal or domestic waste. To document this, they have been marked with the following identification:



Because disposal regulations may differ from one country to another within the EU, please contact your supplier if necessary.

In Germany, this is mandatory from March 23, 2006. From this date, the manufacturer has to offer a suitable method of return for all devices supplied after August 13, 2005. For all devices supplied before August 13, 2005, the last user is responsible for the correct disposal.

Transport, storage and disposal

New Brunswick Innova® 44/44R Shaker
English (EN)

15 Appendix A: Remote programming

15.1 Setting up with HyperTerminal



HyperTerminal is only present in Microsoft® Windows® XP and older.

You can use the Microsoft HyperTerminal program on your personal computer to communicate with your shaker:

1. Before you set up HyperTerminal, be sure to check the Mode and Baud Rate parameter settings (see *RS232 Screen on p. 54*).
2. While you are in the *RS232* screen (see Fig. 9-7 on p. 54), set the Mode parameter to Slave, and select the appropriate Baud Rate. The default setting, as you see in your screen, is 19200; your other choices are 9600 or 38400.
3. Connect the RS-232 cable between your computer and the shaker's RS-232 port (see Fig. 7-2 on p. 32).
4. Start HyperTerminal, and follow the steps for Setting a New Connection. When prompted, select the COM port you will be using, then set the COM parameters (see table below).
5. To be sure that you have established a connection with your shaker, turn the shaker OFF, open the HyperTerminal connection, then turn the shaker back ON. Once a connection has been made, the shaker will send an OK to HyperTerminal.
6. You may wish to send a trial command to the shaker (see Sample Test below). We suggest that you enable Caps Lock on your computer, because all commands must be sent as capital letters.

Tab. 15-1: COM Parameters for HyperTerminal

Baud Rate	Enter the setting on your shaker (see Step 2 above)
Data Bits	8
Parity	None
Stop Bits	1
Flow Control	None

Sample Test:

1. To request the current setpoint, type **RS** at the terminal. When you type **R**, you should see the **R** on the computer display. This is an echo character, sent back by the Innova 44/44R. When you type the **S**, you should see the echo **S** displayed at the computer.
2. Use the **Enter** key to send the carriage return control character. This will move the cursor back over the first character.
3. **RS** is a Request command, so your shaker will send back the data corresponding to the command.

15.2 Overview of command sets

Using an optional RS-232 interface, the user has the capability to control various functions of the Innova 44/44R shakers by computer. A detailed command set follows this introduction.

The serial interface uses an echo character protocol setting that is implemented to indicate that a valid character has been received by the shaker. For every character sent by the user computer, the Innova 44/44R will return a matching character. This echo character should be read by the computer and compared to the character that was sent.



When you are sending a command, do not allow the pause between any two characters of your message to last longer than 10 seconds. If it takes any longer, the shaker's serial port will reset itself.

In the following example, the Master (your computer) will command (the **C** in **CS**) the shaker (Slave) to set its speed to **150 RPM**:

Master sends:	Innova 44/44R responds:
CS<Space>150<CR>	CS<Space>150<CR>

In the next example, the Master (your computer) will request that the shaker (Slave) report (the **R** in **RV**) the actual parameters:

Master sends:	Innova 44/44R responds:
RV<CR>	First the echo: RV<CR>
	Then the report: <Arg1><Tab><Arg2><Tab><Arg3>...<Arg6><CR><LF>



On power-up, even if the shaker is not set in Slave mode at the time, the shaker will always send these four characters: OK<CR><LF>. Before starting any communications, be sure to clear the computer's receive buffer.

This is the command set format:

<Command><Space><Arg1><Space><Argn...><Terminator>

Most commands are defined as two capital characters using standard ASCII format (see the command sets provided below).

If a command has additional arguments, the ASCII space control character separates each argument. The command is terminated using the ASCII carriage return control character; an optional line feed control character may also be included but must follow the carriage return character.

When a command is sent that returns data, the characters returned are in ASCII format. Each additional argument returned will be separated by the ASCII space or tab control character; refer to the selected

command for the actual format. Data returned is terminated with a carriage return line feed control character sequence.

The next section provides an Index to the 2 character command codes.

The next four sections provide command sets for your use for Set Commands, Profile Control Commands, Report Request Commands and Set/Get Date & Time.

15.3 Index to command codes

Command Code	Meaning
CL	Command Grow Lamp
CS	Command Speed
CT	Command Temperature
CU	Command UV Lamp
PC	Clear Profile
PM	Profile Mode
PR	Read Profile Step in Memory
PS	Profile Stop/Start
PW	Write Profile Step to Memory
RI	Report Software Version
RP	Report Parameter List
RS	Report Setpoint Values
RV	Report Measured Values
=D	Set Date and Time
?D	Get Date and Time

15.4 Set commands

Code	Meaning	Format
CL	Command Grow Lamp	CL<Space><Arg1><CR> where Arg1=Set Grow Lamp state (0 = off, 1 = on)
CS	Command Speed	CS<Space><Arg1><CR> where Arg1= Agitation setpoint (####)
CT	Command Temperature	CT<Space><Arg1><CR> where Arg1= Temperature setpoint (###.#)
CU	Command UV Lamp	CU<Space><Arg1><CR> where Arg1= Set UV Lamp state (0 = off, 1 = on)

15.5 Profile control commands

Code	Meaning	Format
PC	Clear Profile (clears profile step)	PC<Space><Arg1><Space><Arg2><CR> where Arg1= Profile number (range 1 to 4) and Arg2=Step number (range 1 to 15) NOTE: If Arg2 is not included, all 15 steps of the selected profile will be cleared.
PM	Profile Mode (returns status of current profile run/hold mode)	PM<CR> There are no parameters to this command. Return data format: <Arg1><Space><Arg2><Space><Arg3><CR> where Arg1=Run/hold status (0 = end, 1 = run), Arg2=Profile number and Arg3=Step number NOTE: If a profile has not been selected to run, a 0 will be returned for Profile number and Step number.
PR	Read Profile step in memory	PR<Space><Arg1><Space><Arg2><CR> where Arg1= Profile number (range 1 to 4) and Arg2=Step number (range 1 to 15) Return data format: <Arg1><Space><Arg2><Space><Arg3><Space>...<CR><LF> where Arg1=Profile number (range 1 to 4), Arg2=Step number, Arg3=Temperature setpoint, Arg4=Agitation setpoint, Arg5=CO ₂ setpoint (future option, reads 0.0), Arg6=Step hours, Arg7=Step minutes, Arg8=UV lamp, and Arg9=Grow lamp
PS	Profile Stop/Start (stops or starts a program profile)	PS<CR> With no other parameters, any profile currently running will be stopped. PS<Space><Arg1><Space><Arg2><CR> where Arg1=Profile number (range 1 to 4), and Arg2=Step number (range 1 to 15). NOTE: If Arg2 is not included, the profile will start in Step 1.
PW	Write Profile step to memory	PW<Space><Arg1><Space><Arg2><Space><Arg3><Space>...<CR> where Arg1=Profile number (range 1 to 4), Arg2=Step number (range 1 to 15), Arg3=Temperature setpoint, Arg4=Agitation setpoint, Arg5=CO ₂ setpoint (future option); Enter 0.0, Arg6=Step hours (range 0 to 99), Arg7=Step minutes (range 0 to 59), Arg8=UV lamp (0 = off, 1 = on), and Arg9=Grow lamp (0 = off, 1 = on)

For example, the following PW command:

```
PW<Space>25.0<Space>150<Space>2<Space>30<Space>0<Space>1<CR>
```

will set Program 1, Step 1 to the following conditions:

- Temperature setpoint 25.0 °C
- Agitation setpoint 150 rpm
- Step Time 2 hours 30 minutes
- UV Lamp OFF
- GRO Lamp ON

15.6 Report request commands

Code	Meaning	Format
RI	Report Software Version	RI<CR> Return data format: <Arg1><Tab><Arg2><CR><LF> where Arg1=Display module software version, and Arg2=Control module software version
RP	Report Parameter List (ASCII text header)	RP<CR> Return data format: <Arg1><Tab><Arg2><Tab><Arg3>...<Arg6><CR><LF> where Arg1="Shaker Speed", Arg2="Temperature", Arg3="% Relative Humidity", Arg4="% CO ₂ Concentration", Arg5="Grow Lamp Status", and Arg6="UV Lamp Status"
RV	Report Measured Values	RV<CR>
RS	Report Setpoint Values	RS<CR> Return data format: <Arg1><Tab><Arg2><Tab><Arg3>...<Arg6><CR><LF> where Arg1= Shaker Speed, Arg2=Temperature, Arg3=% Relative Humidity, Arg4=% CO ₂ Concentration (future option, reads 0.0), Arg5=Grow Lamp Status, and Arg6=UV Lamp Status

15.7 Set/Get date and time

Code	Meaning	Format
=D	Set Date and Time	=D<Space><Arg1><Space><Arg2><Space><Arg3><Space><Arg4><Space><Arg5><Space><Arg6><Space><Arg7><CR>
?D	Get Date and Time	?D<CR> Return data format: <Arg1><Tab><Arg2><Tab><Arg3><Tab>...<Arg7><CR><LF> where Arg1=Hours (range 0-23), Arg2=Minutes (range 0-59), Arg3=Seconds (range 0-59), Arg4=Year (range 00-99), Arg5=Month (range 01-12), Arg6=Date (range 1-31), Arg7=Day (range 1-7; 1=Monday, 2=Tuesday...7=Sunday)

For example, this =D command:

```
=D<Space><01><Space><30><Space><00><Space><04><Space><07><Space><04><Space><07><CR>
```

will set the real date and time on your shaker to: 1:30:00 am, 2004, July 4, Sunday.

Index**A**

Accessories.....	75
Alarms	36
Appendix A.....	79

B

Biohazard decontamination	69
---------------------------------	----

C

Calculate the offset value	62
Calibrate screen.....	56
Caution, explanation of	7
Changing screens	34
Cleaning	70
Control knob.....	31
Controls	31
Create a program.....	57

D

Danger, explanation of	7
Decontamination	69
Device overview	
Front view	13
Internal view	14
Rear view	13
Display icons	35
Display screen	48
Disposal	77
Drain the water reservoir	45

E

Edit a program.....	61
Electrical connections	42
Electrical requirements	19

Electrical Specification Plate	19
--------------------------------------	----

Environment	19
-------------------	----

F

Features	31
Fill the water reservoir.....	44

G

General overview	14
Getting started	39
Glide-up door.....	36

H

Hazard symbols	7
Heater	37

I

Inspection and unpacking of equipment	17
Inspection of boxes.....	17
Install flask clamps	41
Install the front grille	21
Install the stacking kit.....	25
Installation	21
Installation of platform	39
Intended use	9
Interior light(s).....	37

L

Lamps screen.....	53
LCD display	32
Level a single shaker	22
Level the optional base	23

M

Manual conventions.....	8
-------------------------	---

<p>Mount Innova 44/44R on optional base23</p> <p>Mute the audible alarm61</p> <p>N</p> <p>Name plate 13</p> <p>Notice, explanation of7</p> <p>O</p> <p>Open the door.....47</p> <p>Optional gassing port kit43</p> <p>Optional humidity monitor43</p> <p>Optional photosynthetic lamps.....43</p> <p>Optional remote alarm36</p> <p>Optional UV germicidal lamp43</p> <p>P</p> <p>Packing list 17</p> <p>Physical location..... 19</p> <p>Platform assemblies39</p> <p>Power interruption64</p> <p>Power switch31</p> <p>Preparing the location 19</p> <p>Product liability 9</p> <p>Program the shaker57</p> <p>Programmed steps57</p> <p>Programs screen56</p> <p>R</p> <p>Refrigeration37</p> <p>Remote programming79</p> <p>Replacement parts.....75</p> <p>Routine maintenance69</p> <p>RS-232 port31</p> <p>RS232 Screen54</p> <p>Run a program.....61</p>	<p>S</p> <p>Safety precautions 47</p> <p>Service 37</p> <p>Set the offset..... 62</p> <p>Set/Get date and time 83</p> <p>Setup screen 51</p> <p>Slide-out platform 64</p> <p>Software interfaces 37</p> <p>Space requirements 20</p> <p>Specifications..... 71</p> <p>Spill pan/water reservoir 36</p> <p>Stack a 4400/4430 on a 44/44R 30</p> <p>Stack a third shaker 30</p> <p>Stack two Innova 44/44R shakers..... 28</p> <p>Start the shaker..... 47</p> <p>Start/stop switch 31</p> <p>Summary screen 50</p> <p>Symbols used..... 8</p> <p>T</p> <p>Temperature offset calibration..... 62</p> <p>Tools 21</p> <p>Transport and storage..... 77</p> <p>U</p> <p>Unpacking of equipment 17</p> <p>User requirement..... 9</p> <p>Using Calspeed 63</p> <p>Using the LCD screens 48</p> <p>Using this manual 7</p> <p>W</p> <p>Warning, explanation of 7</p>
--	---

Index

New Brunswick Innova® 44/44R Shaker
English (EN)

Declaration of Conformity

The product named below fulfills the requirements of directives and standards listed. In the case of unauthorized modifications to the product or an unintended use this declaration becomes invalid. This declaration of conformity is issued under the sole responsibility of the manufacturer.

Product name:

New Brunswick™ Innova® 44/44R

including accessories

Product type:

Incubated / Refrigerated Shaker

Relevant directives / standards:

2014/35/EU: EN 61010- 1, EN 61010- 2- 010, EN 61010- 2- 051

UL 61010- 1, UL 61010- 2- 010

CAN/CSA C22.2 No. 61010- 1, CAN/CSA C22.2 No. 61010- 2- 010

2014/30/EU: EN 61326- 1, EN 55011 Group1, Class A

47 CFR FCC part 15

2011/65/EU: EN 50581

Hamburg, May 24, 2017



Dr. Wilhelm Plüster
Management Board

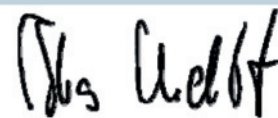

Dr. Thomas Uschkureit
Portfolio Management

Your local distributor: www.eppendorf.com/contact
Eppendorf AG · Barkhausenweg 1 · 22339 Hamburg · Germany
eppendorf@eppendorf.com

ISO 9001
Certified

ISO 13485
Certified

ISO 14001
Certified

Eppendorf® and the Eppendorf Brand Design are registered trademarks of Eppendorf AG, Germany. Innova® is a registered trademark of Eppendorf Inc., USA.
New Brunswick™ is a trademark of Eppendorf AG, Germany.
All rights reserved, incl. graphics and pictures. Copyright © 2016 by Eppendorf AG.

www.eppendorf.com

Evaluate Your Manual

Give us your feedback.
www.eppendorf.com/manualfeedback