



Guide to Operations

**INCUBATOR SHAKER
MODELS G25 & R25
D.C. DRIVE
WITH
SPACE SAVING FAN MOTOR,**

**MANUAL NO.: M1024-0050/R
M1025-0050/R**



NEW BRUNSWICK SCIENTIFIC CO., INC.

BOX 4005 . 44 TALMADGE ROAD . EDISON, NJ 08818-4005 . 732-287-1200
TELEPHONE: 800-631-5417 . FAX: 732-287-4222 . TELEX: 4753012 NBSCO
INTERNET: <http://www.nbsc.com/> . E-MAIL: bioinfo@nbsc.com

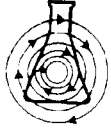

WARRANTY

Every instrument manufactured by the New Brunswick Scientific Co., Inc. is warranted to be free from defects in material and workmanship. This apparatus, with the exception of glassware, lamps and electrodes (where supplied), is warranted for one year against faulty components and assembly and our obligation under this warranty is limited to repairing or replacing the instrument or part thereof, which shall within one year after date of shipment, prove to be defective after our examination. This warranty does not extend to any NBS products which have been subjected to misuse, neglect, accident or improper installation or application; nor shall it extend to products which have been repaired or altered outside the NBS factory without prior authorization from New Brunswick Scientific Co., Inc.. In addition to the above, all biological shakers shipped to the U.S.A. and Canada carry an additional one-year warranty.

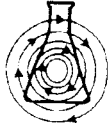

CAUTION

CARE MUST BE EXERCISED IN THE SELECTION OF SPEED AND STROKE COMBINATIONS. UNDER CERTAIN LOADING CONDITIONS, PARTICULARLY WITH HEAVY AND UNEVENLY DISTRIBUTED LOADS, VIBRATION MAY OCCUR AND CAUSE DAMAGE TO THE MACHINE. ALL G25-2" STROKE MACHINES ARE LIMITED TO MAX 300 RPM OPERATING SPEED.

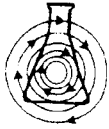
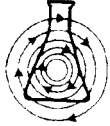

TABLE OF CONTENTS

	<u>PAGE NO.</u>
<u>INTRODUCTION</u>	
Scope of Manual.....	1
Description of Equipment.....	1
Product Specifications.....	2
<u>REFERENCE MATERIAL</u>	
Supplementary Drawings.....	4
<u>INSTALLATION</u>	
Inspection.....	5
Installation.....	5
<u>OPERATION</u>	
Functional Description of Controls.....	6
Operating Procedure.....	6
<u>MAINTENANCE</u>	
Preventive Maintenance.....	10
Techniques.....	10
Corrective Maintenance.....	11
Replacement of Drive Belt.....	11
Drive Motor Lubrication.....	11
Main Housing Bearing Lubrication.....	11
Circulation Blower Motor Lubrication.....	12
Platform Removal.....	12
Lid Adjustment.....	12
Thermostat Calibration.....	12
Overload Protection.....	14
Replacement Parts.....	15
Clamp Mounting Hardware Kit.....	19



IMPORTANT NOTICE

RETURN MATERIAL AUTHORIZATION POLICY

NO RETURNED MATERIAL OR EQUIPMENT WILL BE ACCEPTED WITHOUT A RETURN AUTHORIZATION WHICH IS ISSUED BY THE SERVICE DEPARTMENT.

**CALL THE SERVICE DEPARTMENT FOR RETURN AUTHORIZATION AT:
1-800-237-2298**

THE RETURN AUTHORIZATION NUMBER MUST APPEAR ON THE OUTSIDE OF ALL CARTONS.



INTRODUCTION

SCOPE OF MANUAL

This manual contains the installation, operating and maintenance instructions, plus a description of the Incubator Shaker, Models G25 and R25, manufactured by the New Brunswick Scientific Co., Inc., 44 Talmadge Road, P.O. Box 4005, Edison, New Jersey 08818-4005, U.S.A..

The following versions of this equipment are covered by this manual.

<u>Catalog No.</u>	<u>Part No.</u>	<u>Voltage</u>	<u>Hz</u>	<u>Stroke</u>	<u>Size</u>	<u>Supplement Sheet</u>
G25	M1024-0000	115V-1Ph	60	1"	Std.	No
	M1024-0001	230V-1Ph	50	1"	Std.	No
	M1024-1000	115V-1Ph	60	1"	King	No
	M1024-1001	230V-1Ph	50	1"	King	No
	M1024-2000	115V-1Ph	60	¾"	Std.	Yes
	M1024-2001	230V-1Ph	50	¾"	Std.	Yes
	M1024-3000	115V-1Ph	60	¾"	King	Yes
	M1024-3001	230V-1Ph	50	¾"	King	Yes
	M1024-4000	115V-1Ph	60	2"	Std.	Yes
	M1024-4001	230V-1Ph	50	2"	Std.	Yes
	M1024-5000	115V-1Ph	60	2"	King	Yes
	M1024-5001	230V-1Ph	50	2"	King	Yes
R25	M1025-0000	115V-1Ph	60	0-3 ½"	Std.	No
	M1025-0001	230V-1Ph	50	0-3 ½"	Std.	No
	M1025-0002	115V-1Ph	60	0-3 ½"	King	No
	M1025-0003	230V-1Ph	50	0-3 ½"	King	No

DESCRIPTION OF EQUIPMENT

The Incubator Shaker combines the advantages of a controlled temperature incubator with the efficiency of a continuous duty shaking apparatus. The Gyrotory Shaker, Model 25, is built for continuous service and reproducible agitation. Acting through a triple eccentric drive, a powerful ball bearing motor rotates the shaking platform horizontally in a circular orbit.

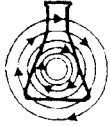

INTRODUCTION

To minimize friction and stress, the platform rotates on nine life-time ball bearings of high thrust and load bearing capacity. In addition, the bearing housing is designed with grease fittings to permit periodic lubrication. With the Reciprocating Shaker, Model R25, workloads roll smoothly and quietly on four sealed ball bearings in precision machined tracks. Instead of sliding the shaker platform, a roller action design is employed which allows heavy loads to be agitated for long periods of time.

The environment growth chamber is thoroughly insulated and has an extremely low heat transfer coefficient for close temperature uniformity. Work is observed through a hermetically sealed, double pane viewing window in the incubator lid. An adjustable air intake vent in the chamber permits room air to circulate through the incubator when required, without affecting temperature regulation.

An automatic switch in the drive circuit de-energizes the shaker when the incubator lid is opened. To insure operating temperature, a safety thermostat is incorporated in the heater circuit. Thermostats are fitted with tension lock-knobs to prevent inadvertent change of temperature.

PRODUCT SPECIFICATIONS

Temperature Range:	Approximately 5°C above ambient to 60°C
Recovery Time:	Approximately 45 sec. (at 37°C) for chamber to recover to 37°C after lid is opened for 10 sec. with ambient air at 25°C
Stroke:*	Rotary motion - 1" circle reciprocating motion - variable from 0 to 3 1/2"
Speed Range:*	Rotary - 40 to 400 RPM reciprocating - 30 to 285 strokes/min.
Dimension - External (with lid closed):	
	Length: 22"
	Width: 45 1/2"
	Height: 30 1/2"
Dimensions Chamber:	
	Length: 22"
	Width: 34 1/2"
	Height: 12 1/2" (optional king size 19 1/2")



INTRODUCTION

Drive Motor:	1/6 HP D.C. Drive
Net Weight:	325 lbs. (optional king size 350 lbs.)
Electrical:	See Unit Specification Plate

*Please refer to the attached supplement for additional information pertaining to additional counterweights supplied with unit (*see pages 24, 25, 26, 27 and 28*).

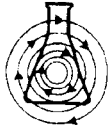

REFERENCE MATERIAL

Supplementary Drawings

Supplementary drawings are supplied with this manual and are listed as follows:

- Control Schematic
- Wiring Diagram

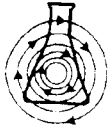

INSTALLATION

INSPECTION

When uncrated, the Incubator Shaker should be inspected for any possible damage which may have occurred during transit. Carefully unpack the Shaker and any of the optional equipment ordered with the unit. Report any obvious damage to the Carrier and to the New Brunswick Scientific Company, Inc.

INSTALLATION

For efficient temperature control, the Incubator Shaker should be placed in a shaded area away from sources of excessive heat.

Check the electrical specifications plate on the Shaker to make certain that the power supply matches the electrical requirements before making connections.



OPERATION

FUNCTIONAL DESCRIPTION OF CONTROLS

<u>Operating Controls</u>	<u>Function</u>
Main Power - Switch	Applies power to the Incubator Shaker Circuitry.
Shaker - Switch	Applies power to the drive motor circuitry through a cover safety switch.
Heater - Switch	Applies power to the Fan Motor & the Heater through the operation of both Thermostats.
Control Thermostat	Controls Chamber temperature.
Safety Thermostat	Secondary Thermostat, provides de-energizing of heater in case of Control Thermostat failure.



NOTE:

Lid must be closed for drive operation.

Tachometer Indicates speed of the shaker table in RPM.

OPERATING PROCEDURE FOR SHAKER

Set all switches on the Shaker OFF.

Rotate the SPEED control fully counterclockwise (minimum speed).

When a Model G25 is supplied, proceed to step (d). When a Model R25 is supplied, the stroke of the machine must be adjusted first before loading the platform. To adjust the stroke, proceed as follows:

- a. Remove the four screws located near the platform center with the Allen Wrench provided.
- b. Attached to the "T" Wrench provided, by a chain, is a Locking Pin. Insert the Locking Pin in the hole in the Eccentric Wheel, and loosen the locking nut on top of the Eccentric Wheel with the "T" Wrench. Position the pointer to the desired stroke engraved on the Eccentric Wheel. Each mark equals 1/2" of stroke. (Stroke length is the total platform movement.)

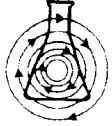

OPERATION

- c. After adjusting the desired stroke, tighten the locking nut with the “T” Wrench and Locking Pin from the Shaker.
- d. Attach the platform to the Shaker drive mechanism with the four screws previously removed, and close the lid.

CAUTION:
WEAR PROTECTIVE GLOVES AT ALL TIMES
WHEN HANDLING GLASSWARE.

Open the lid of the Shaker and load the platform evenly. When the platform is loaded, close the lid.



NOTE:

A safety switch is activated by the lid which removes power from the Shaker table motor when the lid is opened.

Set the *Main Power* switch *On*.

Set the *Shaker* switch *On* and adjust the Speed Control until the desired RPM is indicated on the tachometer.



NOTE:

To achieve maximum speed with low line voltage, variac output may be changed from Tap #3 to #4 when operating at maximum speed.

CAUTION:
THIS CHANGE MUST BE MADE BY A LICENSED
ELECTRICIAN WITH THE POWER TURNED OFF.

Set the *Heater* switch *On* and adjust the thermostat as follows:

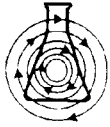

OPERATION



NOTE:

Both thermostats are provided with a locking tab. When it is desired to change the temperature setting of either thermostat, the locking tab must be held pressed in. The locking tab should be released when the desired setting is reached.

Temperature is controlled by a *Control Thermostat*. A *Safety Thermostat* is also provided to prevent overheating, should the *Control Thermostat* ever fail. The *Control Thermostat* can be set at a point that will bring the incubator chamber to the desired temperature, while the *Safety Thermostat* is set for an operating temperature approximately 2°C higher. If for some reason the chamber temperature should begin to rise above the desired level, temperature will automatically be taken over by the *Safety Thermostat*, which will prevent the operating temperature from rising more than 2°C above the desired setpoint. This condition will be indicated by the *Safety Thermostat* indicator light. Operation of the apparatus need not be interrupted in the event of *Control Thermostat* failure. If necessary, the auxiliary (*Safety Thermostat*) may be employed temporarily as a main thermostat, and may be set to regulate the incubator at the desired temperature, until the source of the failure is located and corrected.

CAUTION:

THE SAFETY THERMOSTAT MUST NOT BE USED CONTINUOUSLY AS THE PRIMARY CONTROLLER AS THIS WOULD DEFEAT THE SAFETY FEATURE OF HAVING BACK-UP CONTROL.

The thermostat dials are divided into 100 graduations which have no temperature significance. However, the thermostat knobs have been oriented at the number "37" to correspond with a control temperature of 37°C.

To attain operating temperature of 37°C, set the *Control Thermostat* at "37" and set the *Heater switch On*. The Indicator Lamp will light, indicating that the heater has been energized.

Set the *Safety Thermostat* two graduations higher than the *Control Thermostat*. Wait until the incubator temperature reaches a state of equilibrium before proceeding. A 30 to 60 minute warm-up period is required (depending on operating temperature), to stabilize temperature in the incubation chamber.



OPERATION

For operating temperatures above 37°C, first bring the incubator temperature to 37°C, and then adjust the dial setting as required, moving the knob approximately one graduation for each degree of temperature adjustment required. Some fine tubing may be necessary. With each adjustment of the main thermostat, advance the safety thermostat correspondingly so that it is always approximately two graduations higher than the main thermostat setting.



NOTE:

A fresh air vent is provided on the left-hand side of the lid. This may be opened by turning counter-clockwise.

When it is desired to remove a flask or test-tube from the Incubator Chamber, open the lid. A safety switch activated by the lid removed power from the drive motor.

When the optional gassing fittings are supplied, they are located on the right-hand side of the unit facing the front. One fitting is used to admit gases to the chamber, the other is for removal.

The gassing fittings may also be used in conjunction with the vent control on the right-hand side of the lid.

To shut-down the unit, rotate the *Speed Control* to the minimum setting and set all switches OFF.

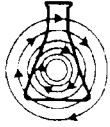

MAINTENANCE

PREVENTIVE MAINTENANCE

Preventive maintenance is performed to keep equipment in proper working order. When periodically performed, preventive maintenance will result in longer life for the equipment and will reduce time lost due to equipment failure.

TECHNIQUES

CLEANING

Use a clean, dry, lint-free cloth, or a dry brush for cleaning the interior of the Shaker Chamber. If necessary, wipe any parts of the interior with a cloth saturated with water or a commercial scouring cleanser. Do not use steel wool or other abrasives which will mar the finish.

WARNING:
DO NOT USE A CLEANING COMPOUND
THAT IS FLAMMABLE OR TOXIC.

PERIODIC INSPECTION

At three-month intervals, perform the following checks and inspections with all switches OFF.

1. Check the fuses on the equipment for good contacts.



NOTE:

On 208 and 220 volt units, two fuses are located behind the rear panel.

2. Remove dirt from the panels, cabinet, wiring cables and motor.
3. Check all controls and accessible items (switches, knobs, connectors, pilot lights, fuse holders, screws, nuts and bolts) to make sure that they are properly tightened. Tighten any item that is loose.
4. Check that all controls operate easily.

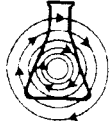

MAINTENANCE

CORRECTIVE MAINTENANCE

REPLACEMENT OF DRIVE BELT

To replace the drive belt, proceed as follows:

1. Set all switches on the shaker to OFF.
2. Disconnect the power cord from the electrical outlet.
3. Remove the screws holding the left lower panel when facing the front of the shaker.
4. Remove the screws holding the Control Panel and lay the Panel forward. This provides access to the motor plate clamping bolt assembly.
5. Loosen the bolt on the motor mounting plate. Switch the motor and plate towards the center of the Shaker. The belt can now be removed and replaced.
6. Slip the new belt over the flywheel and motor pulley and reverse the procedure for installation of the belt.

DRIVE MOTOR LUBRICATION

Drive motor does not require lubrication.

MAIN HOUSING BEARING LUBRICATION

1. Set the *Main Power* switch *Off* and remove the line cord plug from electrical receptacle.
2. Remove the six front panel screws and carefully lower the front panel.
3. Using a grease gun with 90° head, grease the fittings which are now accessible from the front of the unit. Use a high-grade, high-temperature, ball bearing grease and lubricate every three months.

DO NOT OVER LUBRICATE



NOTE:

Model G25 contains 4 grease fittings on the lower eccentric shaft housing. The upper housing contains sealed bearings.

Model R25 contains two grease fittings.

4. After lubrication, replace front panel and screws.
5. Insert power cord from unit to suitable electrical outlet.

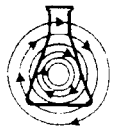

MAINTENANCE

CIRCULATION BLOWER MOTOR LUBRICATION

Permanently sealed - no lubrication required.

PLATFORM REMOVAL

To remove platform, simply unscrew the 4 retaining screws and lift out. Make sure retaining screws are thoroughly tightened when platform is replaced.

LID ADJUSTMENT

In the event the lid fails to remain fully raised when opened, it can be easily corrected by a simple tension adjustment. Hold lid fully open and tighten nut in lower section of both rear hinges.

THERMOSTAT CALIBRATION

The Control thermostat knob may be oriented at a specific dial setting to correspond with operating temperature of the equipment by repositioning knob in relation to the dial plate. In addition, the high and low temperature "stop" may be reset at a new position if it is not possible to attain required temperature. First determine whether the *Safety Thermostat* is interfering with the operation of the *Control Thermostat*. If so, the *Safety Thermostat* should be taken out of the circuit by rotating the knob to its highest setting. If this fails, the Adjustable Stop of the *Safety Thermostat* must be reset to a new position. (Refer to steps 10-14.) To calibrate *Control Thermostat* knob at 37°C (for example) proceed as follows:

1. Remove *Control Thermostat* knob by loosening its two set screws (See Figure 5-1).
2. Loosen Adjustable Stop by loosening its set screw.
3. Put machine in operation and set *Control Thermostat Knob Shaft* so as to achieve a temperature of 37°C. (It may be helpful to first "KEY" the position of the Knob Shaft as an aid in orienting it.)
4. Allow temperature to stabilize before proceeding. This condition will be apparent when the Heater cycles on and off at frequent intervals, (as indicated by the Heater Pilot Light).
5. Without changing the position of the Knob Shaft, move Adjustable Stop until it is in contact with the Shaft Pin. Temporarily lock the "Stop" in position to secure position of Knob Shaft.

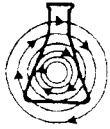

MAINTENANCE

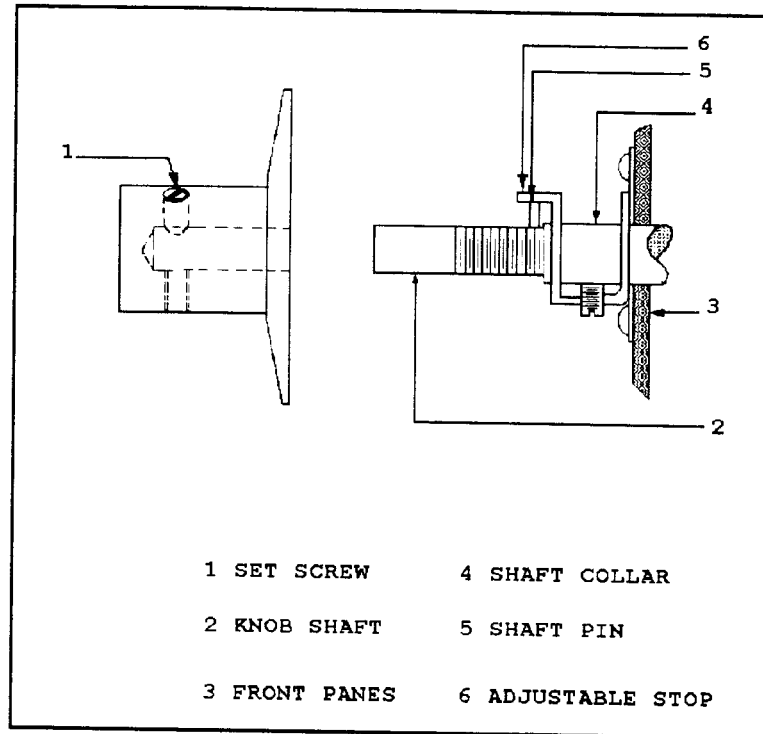
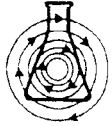

FIGURE 5-1 - THERMOSTAT CALIBRATION

- Without disturbing position of the Knob Shaft, replace knob on the outermost portion of the shaft, and point it to a setting of "37" on the dial. Tighten knob in new position. Make sure knob is firmly in contact with the "Adjustable Stop" before it is secured.
- Loosen Adjustable Stop and set it at a position so that Thermostat Knob can be moved over the entire scale and does not exceed high and low temperature limits.

CAUTION:
DO NOT RESET THERMOSTAT FOR A HIGHER TEMPERATURE THAN THAT WHICH THE APPARATUS IS DESIGNED AND RATED FOR.



MAINTENANCE

8. Lock Adjustable Stop in its new position by tightening its set screw. (The new temperature attainable at this position will be maximum [or minimum] that can be reached.)
9. Rotate the knob fully counter-clockwise. Loosen the set screws on the knob and push the knob as far as possible towards the panel, then back out from the panel 1/32". Tighten the set screws on the knob. This permits the proper tension to be applied to knob by the locking tab. After the Control Thermostat has been calibrated at 37°C, proceed to calibrate the Safety Thermostat.
10. Repeat steps 1 and 2 outlined previously.
11. During Heat cycle, when Heater pilot light is on, move Safety Thermostat Knob shaft slowly until Safety Thermostat pilot lights and the Control Thermostat pilot light goes out.
12. Then rotate knob back slightly to the precise point where the Safety pilot light goes out. This setting will correspond to operating temperature.
13. Repeat steps 5 through 9 outlined previously.
14. Ascertain whether Safety thermostat takes over temperature control when set several degrees lower than the Control thermostat. Return Safety thermostat to original value.

OVERLOAD PROTECTION

On 115 volt models, two fuses are provided on the front panel; one fuse is for the heater, the other fuse is for the drive motor. On 230 volt models, two additional fuses are located behind the front panel. These fuses are used for incoming power. For fuse values, refer to the wiring and schematic diagrams supplied.



MAINTENANCE

REPLACEMENT PARTS

The replacement parts are listed as follows:

TABLE 5-1 REPLACEMENT PARTS

<u>PART NO.</u>	<u>DESCRIPTION MODELS G25 & R25</u>	<u>QTY/UNIT</u>
M1024-3003	Motor (D.C.)	1
P0460-0153	Motor Drive	1
P0341-7380	Resistor, .1 Ohm	1
R-352	Drive Belt (G25)	1
R-466	Drive Belt (R25)	1
ER-102	Fuse Receptacle	1
EC-186	Electrical Cord Set (115 Volt Units)	1
P0720-2020	Electrical Cord (220 Volt Units)	1
ET-151	Thermostats (Control & Safety)	2
H-1506	Knob & Lock Spring for Thermostats	2
ER-114*	Relay	1
P0400-0470	Switches	3
EI-107	Indicator Lamps (Amber) (115V)	2
P0300-0370	Indicator Lamps (Amber) (230V)	3
G25-239	Heater Assembly (115V & 220V)	1
G25-240	Heater Assembly (220V only *)	1
H-401	Thermometer	1
R-100	Rubber Feet	12
P0620-2560	Blower Motor	1
ES-209	Door Switch	1
G25-484	Hinge	2
P0380-3080	Fuse (2 amp) 115/230/208V	1
EF-128	Fuse (10 amp) 115V	1
P0380-3531	Fuse (1.6 amp) 230/208V	1
EF-123	Fuse (5 amp) 230/208V	1
EF-120	Fuse (5 amp) 230/208V	1
P0380-3440	Fuse (0.1 amp) 115/230/208V	1
P0380-6630	Fuse Receptacle	1
P0380-1181	Motor Brush	2

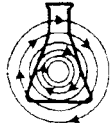

MAINTENANCE

REPLACEMENT PARTS LIST

<u>PART NO.</u>	<u>DESCRIPTION (MODEL G25)</u>	<u>QTY/UNIT</u>
G25-155	Main Bearing Housing Assembly (for units having 1" stroke)	1



NOTE:

The following are the individual components of the G25-115 Main Bearing Housing Assembly.

G10-147	Bearing Retainer Washer	3
1/4-20 x 1/2"	Socket Head Cap Screw	3
G10-103	Upper Bearing Housing (casting)	1
6-32x1/4"lg	Round Head Machine Screw w/ flat washer	9
B-162	Bearings	3
H-890	Shims	as req'd
H-156	Roll Pins	3
G25-197*	Idler Shaft - 1" stroke assembly	2
G25-196*	Main Shaft - 1" stroke assembly	1
B-109	Bearing	4
B-100	Bearing	2
H-142	Retaining Ring	2
H-146	Retaining Ring	2
H-642	Oil Seal	3
H-158	Retaining Ring	1
H-193	Grease Fitting	4

* Please refer to the supplement in order to obtain proper parts number for units with stroke other than 1".

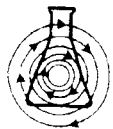

MAINTENANCE

REPLACEMENT PARTS LIST

<u>PART NO.</u>	<u>DESCRIPTION (MODEL R25)</u>	<u>QTY/UNIT</u>
R25-130	Main Bearing Housing Assembly	1



NOTE:

The following four components comprise the main items incorporated in the No. R25-130 Main Bearing Housing Assembly.

R25-103	Lower Bearing Housing (Casting)	1
R25-129	Drive Shaft	1
R8-182	Eccentric Wheel	1
B-100	Main Shaft Bearings	2
R25-124	Upper Roller Frame	1
R25-116	Connecting Rod (Drive Shaft to Roller Frame)	1
B-173	Bearings (in Connecting Rod)	2
R26-103	Tracks (for rolling bearings)	4
R25-135	Shafts (for rolling bearings)	4
B-135	Rolling Bearings	4



NOTE:

For electrical components, refer to the electrical drawings supplied.

IMPORTANT:

WHEN PLACING ORDERS FOR REPLACEMENT PARTS OR REQUESTING INFORMATION ON SERVICE, FURNISH THE SERIAL NUMBER OF THE EQUIPMENT APPEARING ON THE SERIAL NUMBER IDENTIFICATION PLATE, LOCATED ON THE INSIDE OF THE CHAMBER DOOR.



MAINTENANCE



SPECIAL NOTE:

The G25 has a unique counter-balancing system which is designed to meet the specific needs of the customer. When using lighter or heavier loads than shaker is designed to accommodate, excessive creeping may be encountered. To prevent creeping with light load, remove counter-balance weights located beneath platform. With heavier loads additional counter-balance weights should be added beneath platform. Additional weights shipped with unit (see pages 24, 25, 26, 27 and 28).

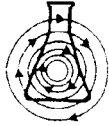

CLAMP MOUNTING HARDWARE KIT

HARDWARE FOR 10mL TO 500mL CLAMPS

NBS flask clamps are used on a variety of shaker platforms. Flat head screws of different lengths and thread pitch are used to secure the clamp. The table below identifies the proper screw for your shaker application by reference to the head style.



10-24 x 5/8 (15.87mm) flat Phillips (+) head screw - part #S2116-3101 Qty. (1) - used on all shakers with a 3/4" (19.05mm) thick wood platform.



10-24 x 5/16 (7.9mm) flat Phillips (+) head screw - part #S2116-3051 Qty. (1) - used on all shakers with a 5/16" (7.9mm) thick aluminum and phenolic platforms.



10-32 x 5/16 (7.9mm) flat slotted (-) head screw - part #S2117-3050 Qty. (1) - used on all stainless steel platforms.

HARDWARE FOR 1 LITER TO 6 LITER CLAMPS

NBS flask clamps are used on a variety of shaker platforms. Flat head screws of different lengths and thread pitch are used to secure the clamp. The table below identifies the proper screw for your shaker application by reference to the head style.



10-24 x 5/8 (15.97mm) flat Phillips (+) head screw - part #S2116-3101 Qty. (5) - used on all shakers with a 3/4" (19.05mm) thick wood platform.



10-24 x 5/16 (7.9mm) flat Phillips (+) head screw - part #S2116-3051 Qty. (5) - used on all shakers with a 5/16" (7.9mm) thick aluminum and phenolic platforms.



10-32 x 5/16 (7.9mm) flat slotted (-) head screw - part #S2117-3050 Qty. (5) - used on all stainless steel platforms.

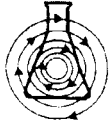

SCHEMATICS

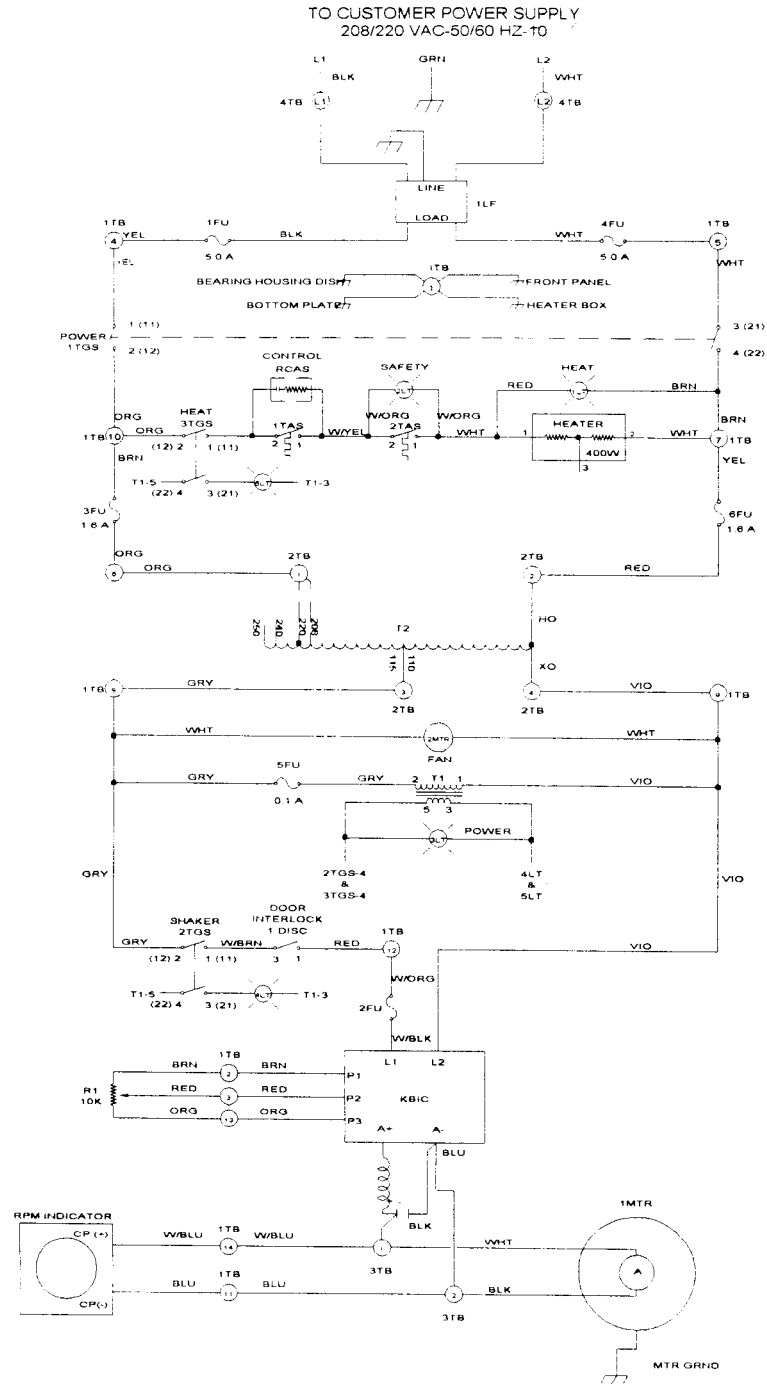

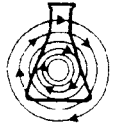

SCHEMATICS

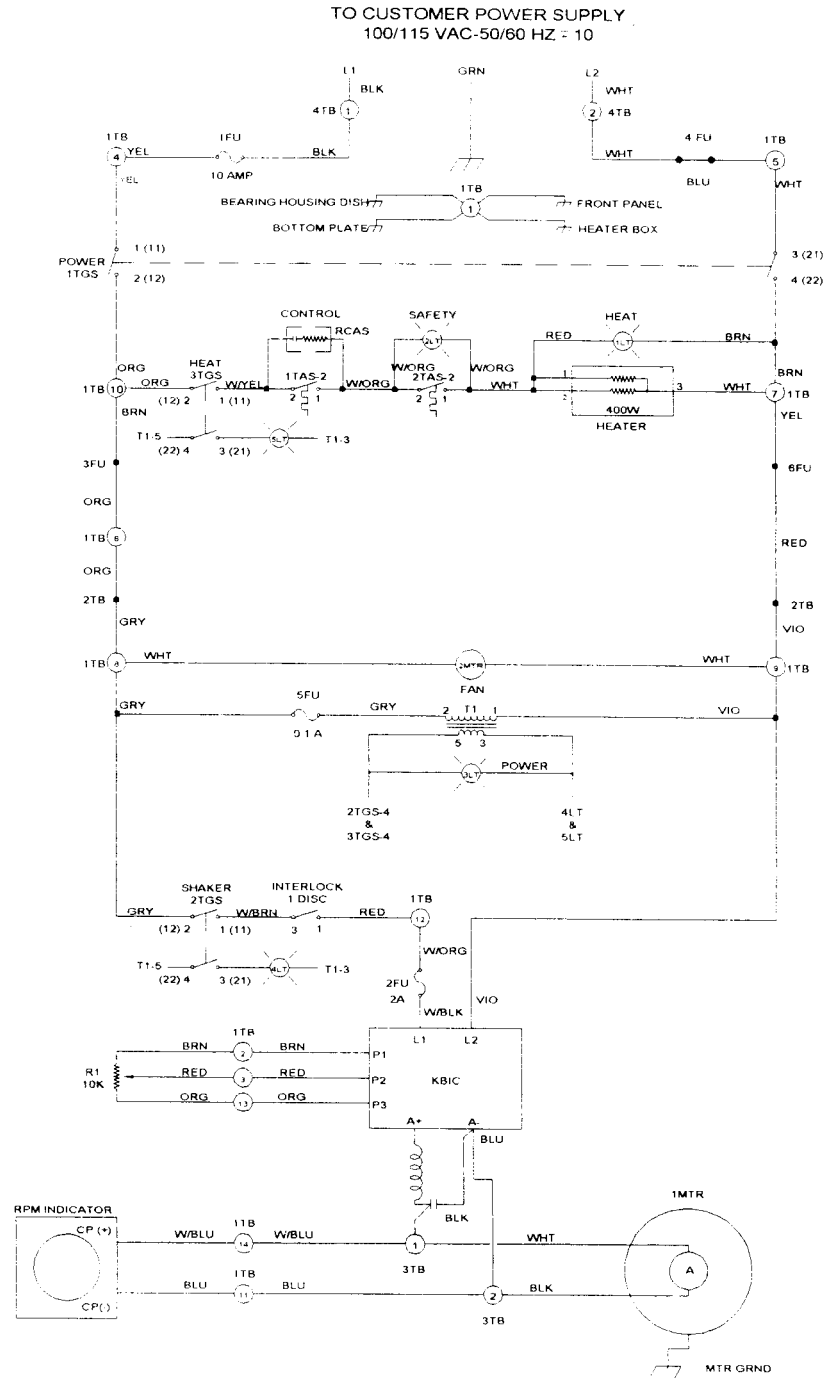

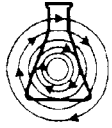

SCHEMATICS

1. ALL POWER CONNECTIONS TO BE MADE TO THE MAIN POWER SUPPLY.
 2. ALL POWER CONNECTIONS TO BE MADE TO THE MAIN POWER SUPPLY.
 3. ALL POWER CONNECTIONS TO BE MADE TO THE MAIN POWER SUPPLY.
 4. ALL POWER CONNECTIONS TO BE MADE TO THE MAIN POWER SUPPLY.
 5. ALL POWER CONNECTIONS TO BE MADE TO THE MAIN POWER SUPPLY.
 6. ALL POWER CONNECTIONS TO BE MADE TO THE MAIN POWER SUPPLY.
 7. ALL POWER CONNECTIONS TO BE MADE TO THE MAIN POWER SUPPLY.
 8. ALL POWER CONNECTIONS TO BE MADE TO THE MAIN POWER SUPPLY.
 9. ALL POWER CONNECTIONS TO BE MADE TO THE MAIN POWER SUPPLY.
 10. ALL POWER CONNECTIONS TO BE MADE TO THE MAIN POWER SUPPLY.

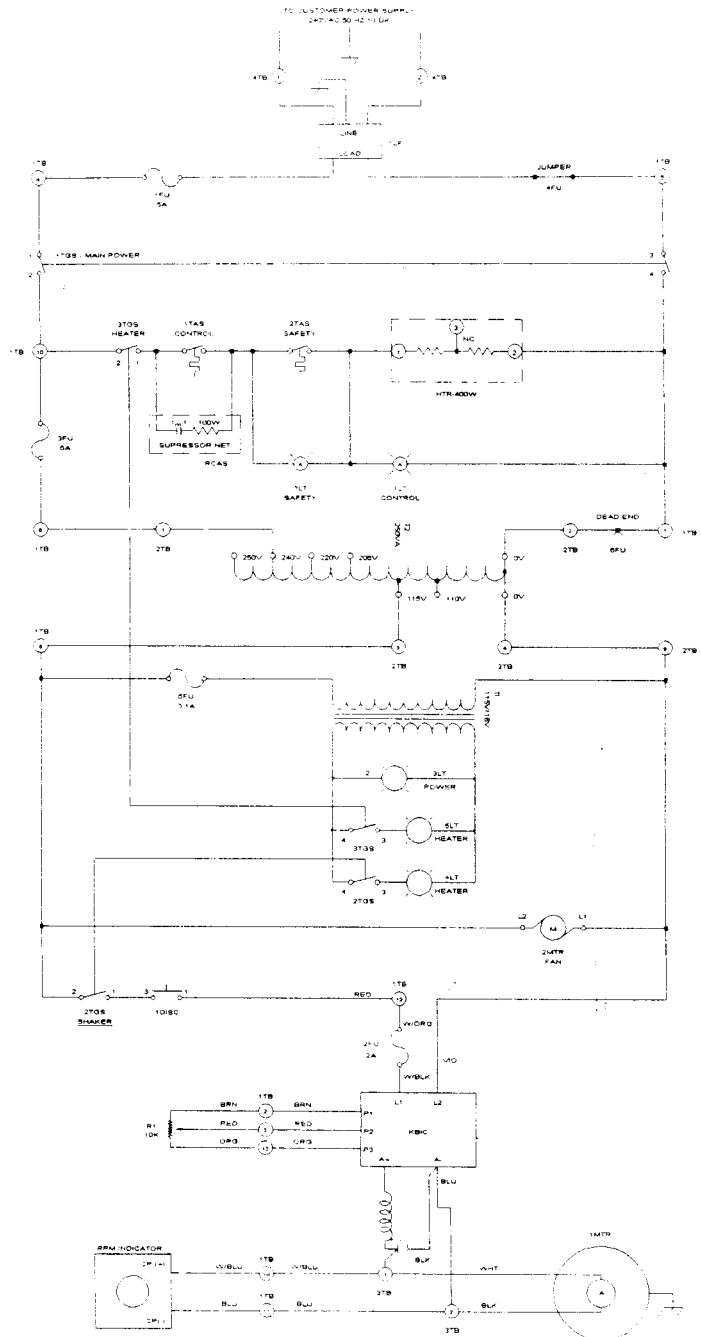

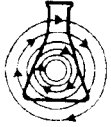

BEARING MOUNTING INSTRUCTIONS

- Associated hardware such as shafts and housings must be designed with proper consideration for bearing mounting surface geometry and fits.
- Associated hardware and assembly tooling must be clean, free of burrs, and demagnetized before contacting bearings.
- Tooling should be designed to mount the bearings squarely onto the shaft and into the housing. Misalignment during installation can severely distort a bearing.
- Apply force only to the ring being press-fitted. Shock or impact techniques should never be used to seat a bearing.
- Tooling must be designed and used in a manner which will observe the basic assembly Do's and Don't's illustrated below.

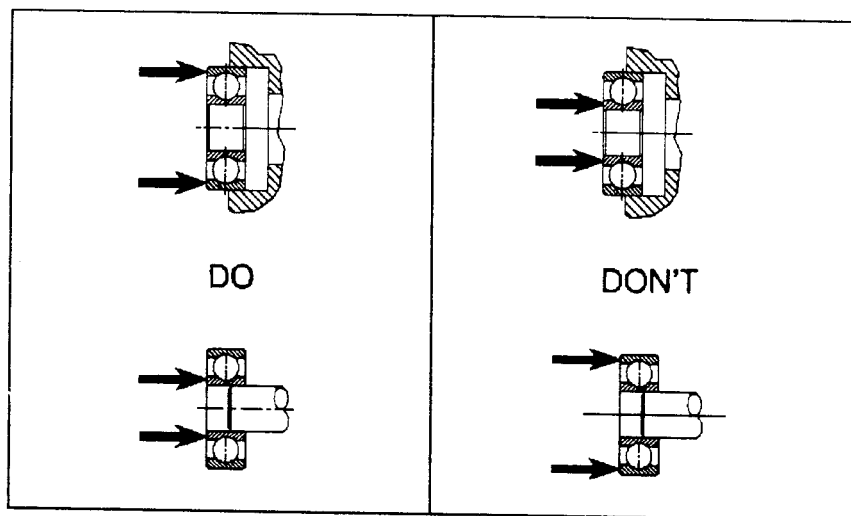

Correct and Incorrect Bearing Mounting Practices

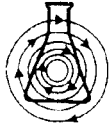

BEARING HOUSING ASSEMBLY

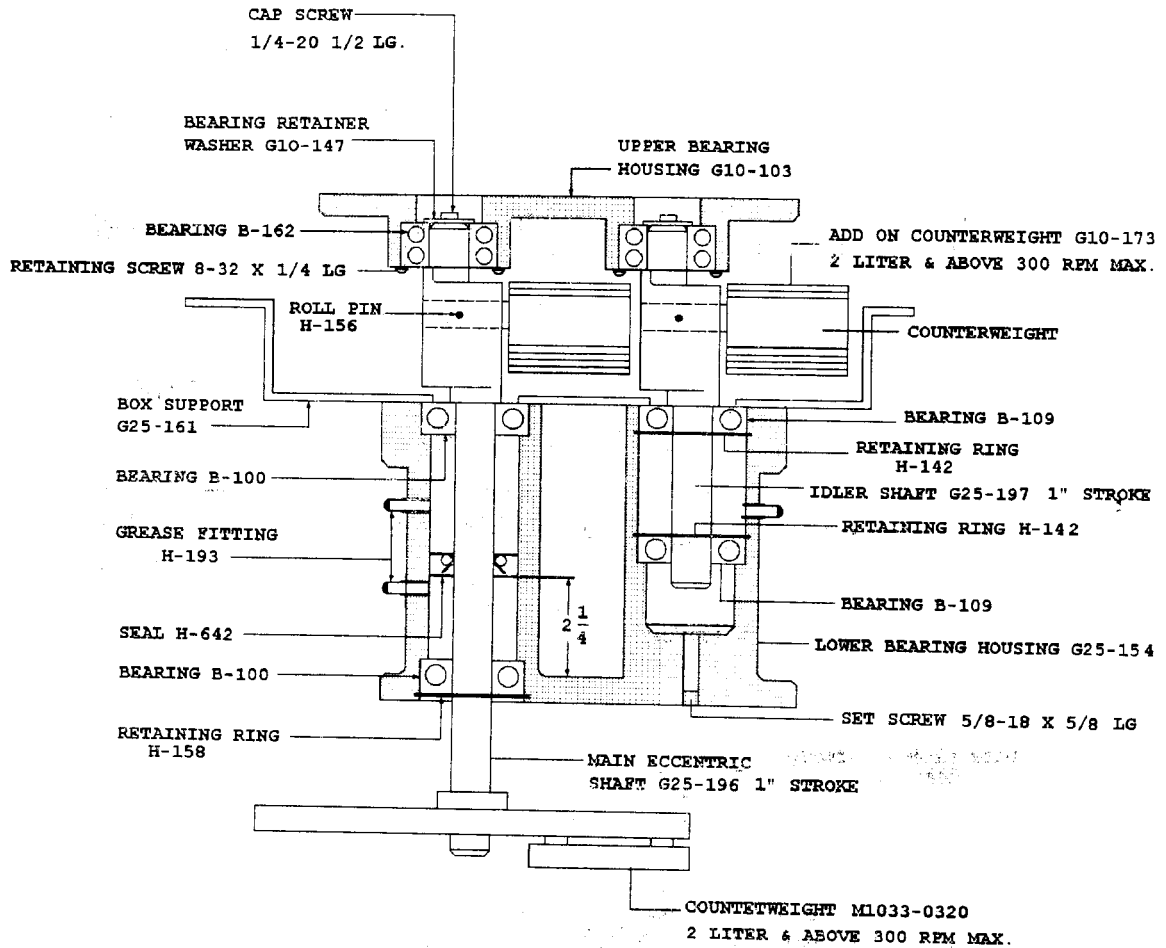

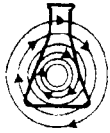

G25

SUPPLEMENT FOR 2" STROKE, LESS THAN 2 LITER

This machine is equipped with 2" eccentrics. It is recommended that the maximum operational speed be limited to 300 RPM.

Since the operating manual parts information for a 1" stroke, an additional parts listing is supplied in order to account for parts that are not reciprocal.

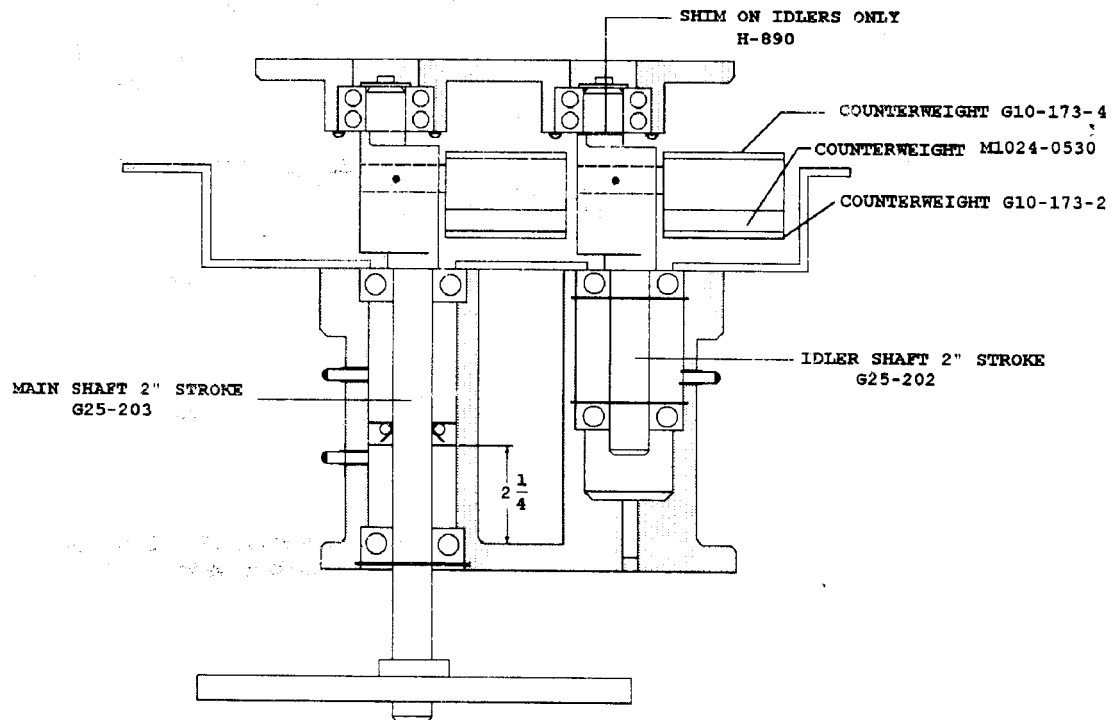

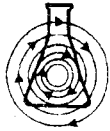

G25

SUPPLEMENT FOR 2" STROKE, 2 LITER AND ABOVE

This machine is equipped with 2" eccentrics. It is recommended that the maximum operational speed be limited to 300 RPM.

Since the operating manual parts information for a 1" stroke, an additional parts listing is supplied in order to account for parts that are not reciprocal.

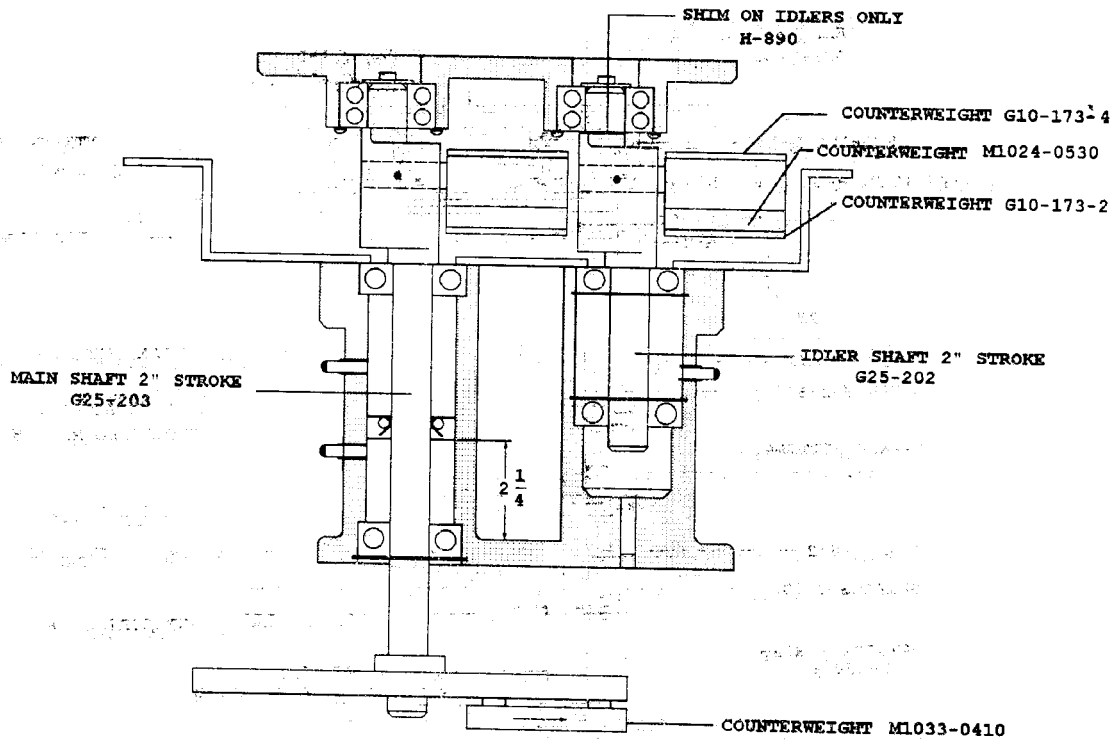

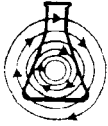

G25

SUPPLEMENT FOR 1" STROKE, 2 LITER AND ABOVE

This machine is equipped with 1" eccentrics. It is recommended that the maximum operational speed be limited to 300 RPM.

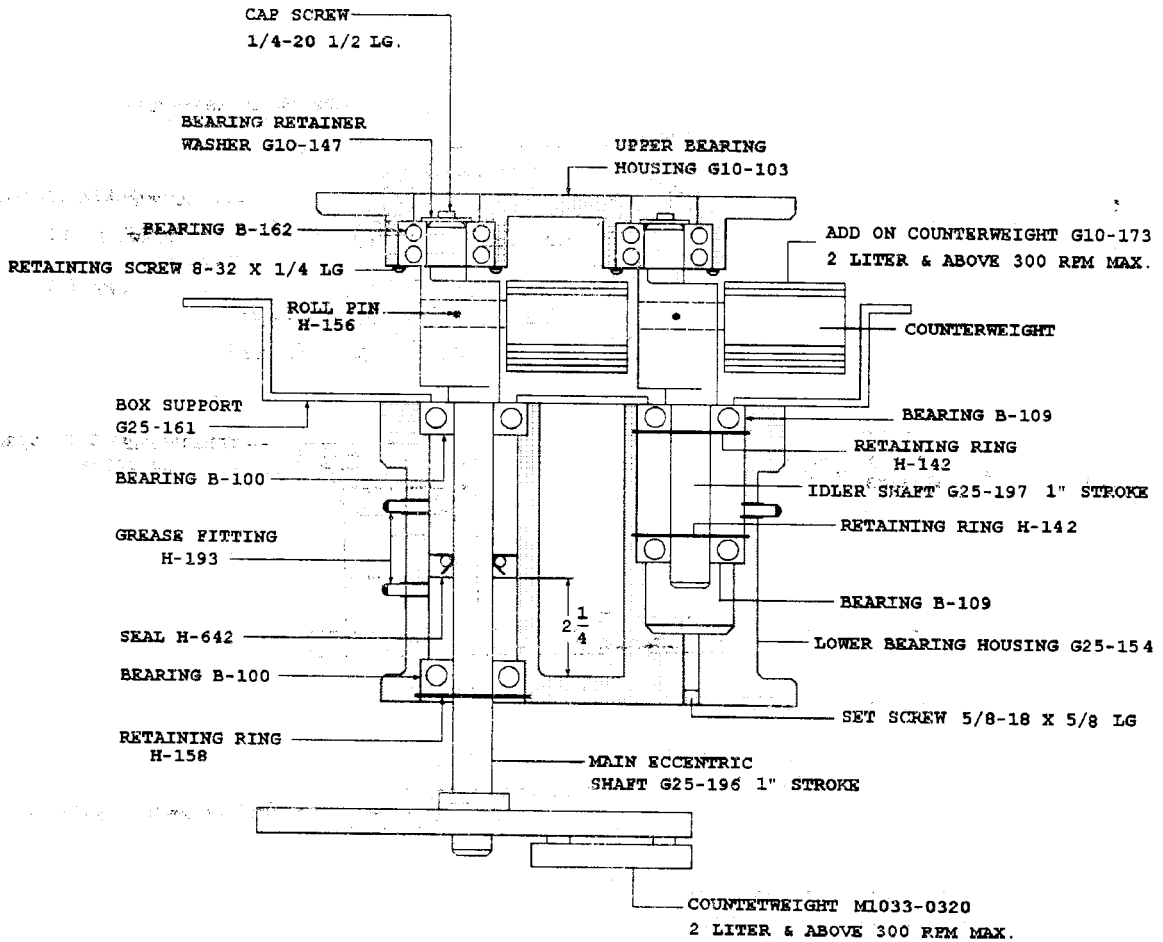

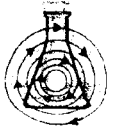

G25

