

LabMaster

The clear cut laboratory mixing solution

The LabMaster achieves the required process results in water-like liquids, high viscosity blending or gas-liquid-solid applications. LabMaster uses microprocessor technology, robust power and advanced laser designed impellers. Custom software produces consistent results and accurately records data that is critical to both validation and scale-up.



An Exceptionally Versatile Mixer

- Largest mixing capacities in the industry
- Reversible rotation for up- or down-pumping experiments
- Patented mixing impellers provide maximum efficiency
- Repeatable digital data entry via splash proof keypad
- Displays speed, power, torque, impeller flow and time
- Dual adjustment clamp—repeatable mixer positioning
- Boss head mount option
- Chemically resistant sanitary housing
- World-wide design, single phase 50 or 60 Hz

Unparalleled Computer Control

- Controls up to 32 mixers from one computer
- Simple computer connection
- 8 critical fluid mixing scale-up parameters recorded
- Validation data easily exported
- Temperature probe included



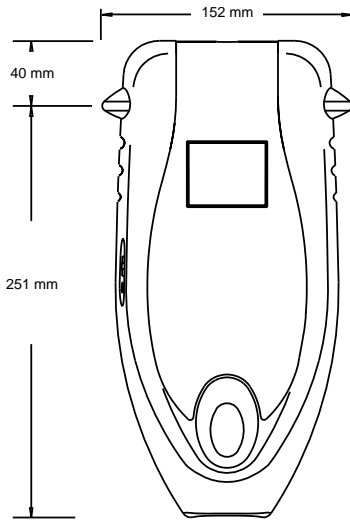

LabMaster					
Model	Catalog No. 115V/60HZ/1PH	Catalog No. 230V/50HZ/1PH	Power (W)	Speed (RPM)	Volume (L)
LIU10*	836275	836282	115	50-1800	200
L5U10	836276	836283	115	20-550	400
LIU10F*	836277	836284	115	50-1800	200
L5U10F	836278	836285	115	20-550	400

F-Computer controlled *Through shaft All shafts are 610 mm long as standard

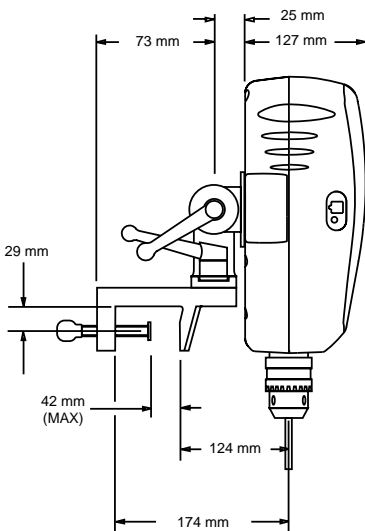

LabMaster Impellers Included								
Model Number	A310 Dia. (mm) (inches)		A100 Dia. (mm) (inches)		R100 Dia. (mm) (inches)		A320 Dia. (mm) (inches)	
LIU10 & LIU10F	86	3.4	69	2.7	51	2.0	--	--
L5U10 & L5U10F	--	--	79	3.1	51	2.0	127	5.0

Worldwide commitment: International certification

These products are CE marked for the European Community, UL listed for the USA, CSA certified for Canada and T marked for Japan. In addition, they are ETL listed and certified for many other countries.

Call the LIGHTNIN experts

For more information about the LabMaster or to discuss your application, contact your local LIGHTNIN Sales Representative. Or visit our website at www.lightninmixers.com. Or call 1-888-MIX-BEST (U.S. and Canada) or +1 (716)* 527-1623 (worldwide).

*After April 1, 2002 use Area Code 585



135 Mt. Read Blvd.
Rochester, NY 14611 USA

www.lightninmixers.com