



LABCONCO CORPORATION

8811 Prospect Avenue
Kansas City, MO 64132
(800) 821-5525, (816) 333-8811
(816) 363-0130 fax
labconco@labconco.com

User's Manual

CentriVap[®] Cold Traps

Models

78110 Series
74600 Series
73850 Series

To receive important product updates,
complete your product registration card
online at register.labconco.com

Please read the User's Manual before operating the equipment.

Copyright © 2019 Labconco Corporation. The information contained in this manual and the accompanying products are copyrighted and all rights reserved by Labconco Corporation. Labconco Corporation reserves the right to make periodic design changes without obligation to notify any person or entity of such change.

Warranty

Labconco Corporation provides a warranty to the original buyer for the repair or replacement of parts and reasonable labor as a result of normal and proper use of the equipment with compatible chemicals. Broken glassware and maintenance items, such as filters, gaskets, light bulbs, finishes and lubrication are not warranted. Excluded from warranty are products with improper installation, erratic electrical or utility supply, unauthorized repair and products used with incompatible chemicals.

The warranty for CentriVap® Cold Traps will expire one year from date of installation or two years from date of shipment from Labconco, whichever is sooner. Warranty is non-transferable and only applies to the owner (organization) of record.

Buyer is exclusively responsible for the set-up, installation, verification, decontamination or calibration of equipment. This limited warranty covers parts and labor, but not transportation and insurance charges. If the failure is determined to be covered under this warranty, the dealer or Labconco Corporation will authorize repair or replacement of all defective parts to restore the unit to operation. Repairs may be completed by 3rd party service agents approved by Labconco Corporation. Labconco Corporation reserves the rights to limit this warranty based on a service agent's travel, working hours, the site's entry restrictions and unobstructed access to serviceable components of the product.

Under no circumstances shall Labconco Corporation be liable for indirect, consequential, or special damages of any kind. This warranty is exclusive and in lieu of all other warranties whether oral, or implied.

Returned or Damaged Goods

Do not return goods without the prior authorization from Labconco. Unauthorized returns will not be accepted. If your shipment was damaged in transit, you must file a claim directly with the freight carrier. Labconco Corporation and its dealers are not responsible for shipping damages.

The United States Interstate Commerce Commission rules require that claims be filed with the delivery carrier within fifteen (15) days of delivery.

Limitation of Liability

The disposal and/or emission of substances used in connection with this equipment may be governed by various federal, state, or local regulations. All users of this equipment are required to become familiar with any regulations that apply in the user's area concerning the dumping of waste materials in or upon water, land, or air and to comply with such regulations. Labconco Corporation is held harmless with respect to user's compliance with such regulations.

Contacting Labconco Corporation

If you have questions that are not addressed in this manual, or if you need technical assistance, contact Labconco's Customer Service Department or Labconco's Product Service Department at 1-800-821-5525 or 1-816-333-8811, between the hours of 7:30 a.m. and 5:30 p.m., Central Standard Time.

TABLE OF CONTENTS

CHAPTER 1: INTRODUCTION	1
Safety Information	2
CHAPTER 2: PREREQUISITES	3
Electrical Requirements	4
Location and Exhaust Requirements	4
Vacuum Pump Requirements	5
Vacuum Line Traps	5
Space Requirements	5
CHAPTER 3: GETTING STARTED	6
Unpacking Your CentriVap Cold Trap	7
CentriVap Cold Trap Components	7
Component Orientation & Hose Connections	8
Electrical Connection	9
Ground Wire	9
Chemical Resistance of CentriVap Cold Trap Components	9
Solvent Safety Precautions	10
CHAPTER 4: MAINTAINING YOUR CENTRIVAP COLD TRAP	12
CHAPTER 5: ACCESSORIES FOR YOUR CENTRIVAP COLD TRAP	14
Installing a Secondary Chemical Trap	16
Installing a Glass Trap in the Cold Trap	17
CHAPTER 6: TROUBLESHOOTING	18
APPENDIX A: CENTRIVAP COLD TRAP COMPONENTS	20
APPENDIX B: CENTRIVAP COLD TRAP DIMENSIONS	27
APPENDIX C: CENTRIVAP COLD TRAP SPECIFICATIONS	30
Electrical Specifications	30
Environmental Conditions	31

Chapter 1:

Introduction

Congratulations on your purchase of a Labconco CentriVap Cold Trap. Models are available for operation on 115V or 230V. The CentriVap Cold Trap protects the vacuum pump by trapping moisture, vapors and corrosive fumes as they evaporate from the samples. The stainless steel trap is used for aqueous and organic applications. For corrosive applications, the optional Glass Trap insert should be used. The 230V 50Hz models comply with CE regulations.

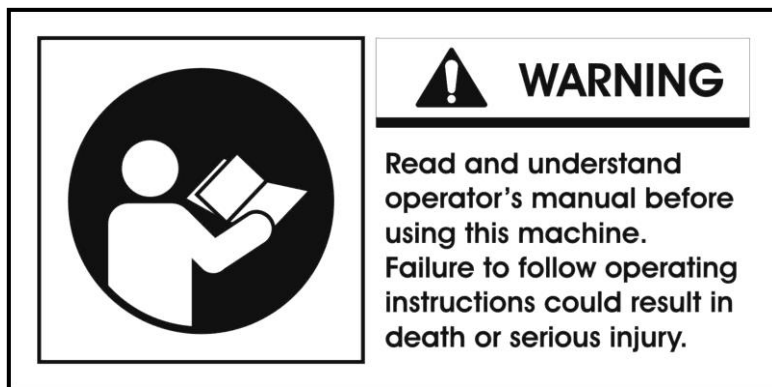

Safety Symbols

Your CentriVap Cold Trap was designed with safety in mind, however conditions may exist that could be hazardous.

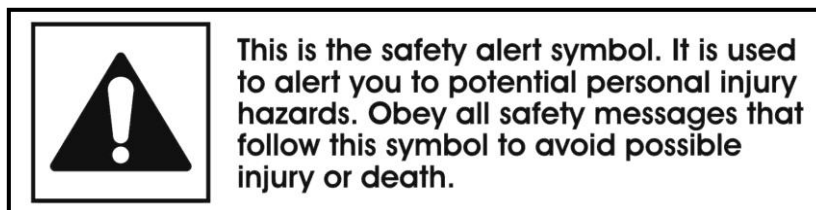

Throughout this manual potentially hazardous conditions are identified using the following words and symbols.



 DANGER	DANGER indicates an imminently hazardous situation which, if not avoided, will result in death or serious injury.
 WARNING	WARNING indicates a potentially hazardous situation which, if not avoided, could result in death or serious injury.
 CAUTION	CAUTION indicates a potentially hazardous situation which, if not avoided, may result in minor or moderate injury.
CAUTION	CAUTION used without the safety alert symbol indicates a potentially hazardous situation which, if not avoided, may result in property damage.

It is important that you understand the warnings listed throughout this manual before you operate the CentriVap Cold Trap.



For Hydrocarbon Refrigeration Only See Below:

- **DANGER** – Risk of fire or explosion. Flammable refrigerant used. Do not use mechanical devices to defrost refrigerator. Do not puncture refrigerant tubing.
- **DANGER** – Risk of fire or explosion. Flammable refrigerant used. To be repaired only by trained service personnel.
- **WARNING** – Keep all ventilation openings in the enclosure or, in the structure for building-in, clear of obstruction.
- **CAUTION** – Risk of fire or explosion. Flammable refrigerant used. Consult repair manual/owner’s guide before attempting to service this product. All safety precautions must be followed.
- **CAUTION** – Risk of fire or explosion. Dispose of properly in accordance with federal or local regulations. Flammable refrigerant used.
- **CAUTION** – Risk of fire or explosion due to puncture of refrigerant tubing. Follow handling instructions carefully. Flammable refrigerant used.



Replacement components and servicing

- Component parts shall be replaced with like components.
- Servicing shall be performed by authorized service personnel to minimize the risk of possible ignition due to incorrect parts or improper service.

Chapter 2:

Prerequisites

Before you install your CentriVap Cold Trap, you need to prepare your site for installation. You must be certain that the area is level and of solid construction. In addition, a means to exhaust the vacuum pump must be provided. An electrical source must be located near the installation site.

Carefully read this chapter to learn:

- The electrical supply requirements.
- The exhaust requirements.
- The vacuum pump requirements.

Refer to Appendix C: CentriVap Cold Trap Specifications for complete electrical and environmental conditions, specifications and requirements.

Electrical Requirements

The CentriVap Cold Trap requires a dedicated electrical outlet. 115V (-50°C & -85°C) Models require a 15 Amp circuit breaker or fuse rated at 115V (60 Hz). 115V (-105°C) Models require a 20 Amp circuit breaker or fuse rated at 115V (60 Hz). 230V Models require an 8 Amp circuit breaker or fuse rated at 230V (50/60 Hz). If the power cord supplied with the Cold Trap does not match the available receptacle, replace it with an approved power cord of the suitable style. See CentriVap Cold Trap Components in Chapter 3 for power cord specifications.

Location and Exhaust Requirements

The CentriVap Cold Trap should be located on a surface that is stable, flat and level.

WARNING: Solvents used in the Cold Trap can cause skin, eye, respiratory and digestive system disorders. The CentriVap Cold Trap System should be located within a fume hood if hazardous or flammable solvents are used. Heating of materials could lead to the liberation of hazardous gases. In all cases, regardless of the solvent used, it is strongly recommended that the vacuum pump is vented in a fume hood. An accessory secondary trap is available to minimize the exhausting of solvents into the atmosphere. This does not, however, negate the need to exhaust the vacuum pump into a fume hood. Failure to properly vent the system will expose personnel to potentially harmful chemicals.

The CentriVap Cold Trap has not been evaluated by an approval agency for the use of biological, radio toxins or flammable liquids or materials.

Vacuum Pump Requirements

The inlet fitting on the vacuum pump must be suitable for 0.50 ID hose.

IMPORTANT NOTE: When selecting the vacuum pump it is very important to consider the flammability of the solvent that will be used. If the solvents are flammable, an explosion-proof vacuum pump or one suitable for the solvents to be processed is recommended. See Chapter 3 Solvent Safety Precautions for solvents suitable for use in the CentriVap Cold Trap.

To ensure that aggressive vapors do not damage the vacuum pump, it is recommended that all internal wetted parts of the vacuum pump are PTFE or PTFE coated when using aggressive solutions.

Chemical Traps

The CentriVap Cold Trap will not provide complete vacuum pump protection under all circumstances. Variables that influence the Cold Traps trapping ability are volatility of the solvents, solvent volumes, solvent temperatures, and vacuum levels. Some scenarios may require a Chemical Trap for additional vacuum pump protection. This in-line cannister is placed after the Cold Trap and before the vacuum pump and holds inserts for specific sample types. Acid, solvent, moisture and radioisotope inserts are available. Refer to Chapter 5: Accessories for Your CentriVap for ordering information.

NOTE: Several components within the CentriVap Cold Trap are made from stainless steel or other materials and can be degraded if exposed to acids. Contact Labconco before evaporating acids.

Space Requirements

Refer to Appendix B: Cold Trap Dimensions for dimensional drawings of the CentriVap Cold Traps.

No person or any hazardous material should be within 12 inches of the CentriVap Cold Trap while it is operating.

Chapter 3: Getting Started

Now that the site for your CentriVap Cold Trap is properly prepared, you are ready to unpack, inspect, install, and test your CentriVap Cold Trap. Read this chapter to learn how to:

- Unpack and move your CentriVap Cold Trap.
- Set up your CentriVap Cold Trap.
- Connect the electrical supply source to your CentriVap Cold Trap.
- Properly exhaust your CentriVap Cold Trap.
- Safely use solvents with your CentriVap Cold Trap.

CAUTION: The CentriVap Cold Trap weighs over 70 lbs. (33 Kg). The carton allows for lifting with a mechanical lift truck or hand truck. If you must lift the Cold Trap manually, use at least two (2) persons and follow safe lifting guidelines.

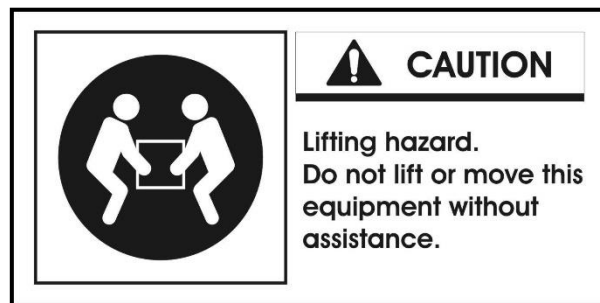

Unpacking Your CentriVap Cold Trap

Carefully unpack your CentriVap Cold Trap and inspect it for damage that may have occurred in transit. If your CentriVap Cold Trap is damaged, notify the delivery carrier immediately and retain the entire shipment intact for inspection by the carrier.

The United States Interstate Commerce Commission rules require that claims be filed with the delivery carrier within fifteen (15) days of delivery.

Do not discard the carton or packing material for your CentriVap Cold Trap until you have checked all of the components and installed and tested the CentriVap Cold Trap.

NOTE: Do not return goods without the prior authorization of Labconco. Unauthorized returns will not be accepted. If your CentriVap Cold Trap was damaged in transit, you must file a claim directly with the freight carrier. Labconco Corporation and its dealers are not responsible for shipping damage.

CentriVap Cold Trap Components

Locate the model of CentriVap Cold Trap you received in the following tables. Verify that the components listed are present. If you do not receive one or more of the components listed for your CentriVap Cold Trap, contact Labconco Corporation immediately for further instructions.

Cold Traps																	
Description				Power Cords								Accessories					
Catalog #	Temperature Rating	Voltage (V)	Frequency (Hz)	Connector: IEC C13 Plug: NEMA 5-15 1334500	Connector: IEC C13 Plug: CEE 777 1336100	Connector: IEC C13 Plug: BS 1363 1332600	Connector: IEC C13 Plug: CH1-10P 1332700	Connector: IEC C13 Plug: NEMA 6-15 1338000	Connector: IEC C19 Plug: NEMA 5-20 1336400	Connector: IEC C19 Plug: CEE 777 1336500	Connector: IEC C19 Plug: BS 1363 1332601	Connector: IEC C19 Plug: CH2-16P 1332701	Connector: IEC C19 Plug: NEMA 6-20 1342100	Tubing 7828606	clamps (2) 1488800	Wire Assembly 7464600	Product Thumb Drive 1089003
7811020	-50°C	115	60	X										X	X	X	X
7811021	-50°C	115	60	X										X	X	X	X
7811030	-50°C	230	50		X									X	X	X	X
7811031	-50°C	230	50		X									X	X	X	X
7811035	-50°C	230	50			X								X	X	X	X
7811036	-50°C	230	50			X								X	X	X	X
7811037	-50°C	230	50				X							X	X	X	X
7811038	-50°C	230	50				X							X	X	X	X
7811040	-50°C	230	60					X						X	X	X	X
7811041	-50°C	230	60					X						X	X	X	X
7460020	-85°C	115	60	X										X	X	X	X
7460030	-85°C	230	50		X									X	X	X	X
7460035	-85°C	230	50			X								X	X	X	X
7460037	-85°C	230	50				X							X	X	X	X
7460040	-85°C	230	60					X						X	X	X	X
7385020	-105°C	115	60						X					X	X	X	X
7385030	-105°C	230	50							X				X	X	X	X
7385035	-105°C	230	50								X			X	X	X	X
7385037	-105°C	230	50									X		X	X	X	X
7385040	-105°C	230	60										X	X	X	X	X

Component Orientation & Hose Connections

The relative position of the CentriVap Cold Trap and the vacuum pump is critical. The Cold Trap should always be placed before the vacuum pump. Air to cool the refrigeration system of the Cold Trap is drawn into the right side of the Cold Trap cabinet and exhausts out the left side of the cabinet. A minimum of 3" should be allowed between the sides of the Cold Trap and the adjacent wall surfaces. Restriction of the airflow through the cabinet during operation could adversely affect performance.

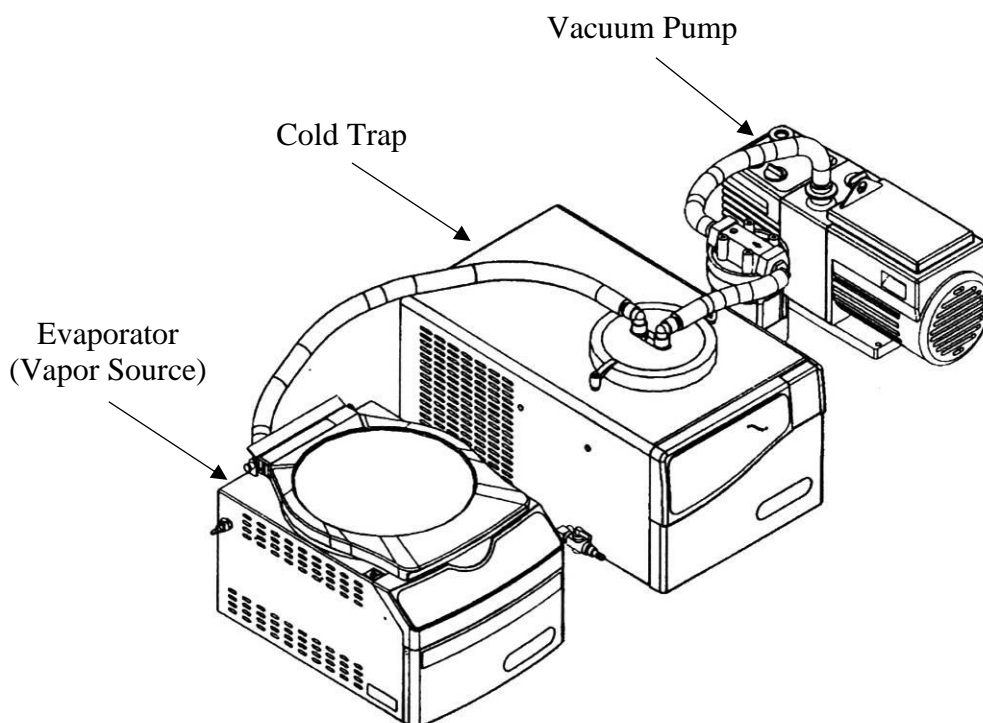

Once positioned properly, the system can be connected with the hoses provided. Attach one end of the hose to the evaporator and the other end of this hose to one of the barb fittings on the Cold Trap Cover Assembly. Secure the hoses with the clamps supplied. Attach another hose to the remaining barb fitting on the Cold Trap Cover and clamp securely. If the accessory Secondary Trap is not used, attach the other end of this hose to the inlet port on the vacuum pump. If the accessory Secondary Trap is used, install the Secondary Trap as explained in *Chapter 5: Accessories for Your CentriVap Cold Trap*.

WARNING: Solvents used in the Cold Trap can cause skin, eye, respiratory and digestive system disorders. Locate the Cold Trap inside a fume hood. It is recommended that the vacuum pump be located inside a fume hood or other laboratory ventilation device if hazardous solvents are being used. If this is not possible, the vacuum pump should have a hose attached to the exhaust port and the other end of the hose should be positioned inside the fume hood or ventilation device.

Electrical Connection

Plug the power cord into the receptacle on the back of the CentriVap Cold Trap and plug the other end into a suitable power receptacle. Plug the power cord from the vacuum pump into a suitable receptacle.

Ground Wire

CAUTION: Solvents may be flammable. When draining the CentriVap Cold Trap always attach the other end of the grounding clip to the solvent catch pot to eliminate the risk of electrostatic spark ignition.

Attach one end of the included ground wire to the stainless steel elbow on the drain tubing on the right or left side (depending on model) of the Cold Trap.

Chemical Resistance of CentriVap Cold Trap Components

Your CentriVap Cold Trap is designed to be chemically resistant. However, by necessity, the Cold Trap is comprised of a number of different materials, some of which may be attacked and degraded by corrosive chemicals. The degree of degradation is obviously dependent on the concentration and duration of exposure. Some major components of the Cold Trap that are susceptible to degradation are as follows:

COMPONENT	MATERIAL	Acids							Bases	Solvents															
		Acetic Acid 20%	Boric Acid	Formic Acid	Hydrobromic Acid 20%	Hydrochloric Acid 20%	Nitric Acid 20%	Sulfuric Acid 10%		Trifluoroacetic Acid (TFA)	Ammonium Hydroxide	Acetone	Acetonitrile	Chloroform	Dimethyl Formamide	Dimethyl Sulfoxide (DMSO)	Ethanol	Ethyl Acetate	Hexanes	Isopropanol	Methanol	Methylene Chloride	Methyl t-Butyl Ether (MTBE)	Toluene	Water
Cold Trap -50°C																									
Chamber	Stainless Steel				D	D		D																	
Lid	Acrylic							C	D	C															
Cold Trap Gasket	Neoprene	D		D	C	D		D		C	D	D	D	D	C	D		D		C	D	D	C	D	
Cold Trap -84°C & -105°C																									
Chamber	Stainless Steel				D	D		D																	
Lid	Stainless Steel				D	D		D																	
Cold Trap Gasket	Neoprene	D		D	C	D		D		C	D	D	D		D						D	C	D		
C- Moderate Degradation- Questionable use																									
D- Severe Degradation- Infrequent use recommended- immediate thorough cleaning required																									

- If a rotary vane vacuum pump is used, frequent oil changes are required. Many compounds will degrade the oil if allowed to enter to pump.
- Diaphragm vacuum pumps sold by Labconco have wetted parts either made from PTFE or protected by PTFE coatings and are suitable for nearly all procedures.

- When using compounds in the CentriVap Cold Trap that are hostile to the materials of construction, it is imperative that the equipment is appropriately maintained. After each run, clean up all residues, spills and materials that might have splashed in the chamber.
- Drain the Cold Trap immediately after the collected ice is melted to prevent corrosive liquids from residing in the trap. Flush out the trap with water after draining.

DO NOT chip ice off the Cold Trap walls as damage may occur.

DO NOT start a rotary vane pump when the Cold Trap contains any liquid or if there is any liquid in the vacuum tubing. The liquid will be drawn into the pump and will contaminate the vacuum pump oil.

- If the stainless steel cold trap chamber is attacked by the compounds in use consider using the optional Glass Trap insert. See Chapter 5: Accessories for Your CentriVap.
- When using a rotary vane vacuum pump the oil in the pump should be checked often. It must be changed if it is cloudy, shows particles or is discolored. The useful life of vacuum pump oil can be extended if the vacuum pump is operated for an extended period of time with the gas ballast open after the run is over. This allows contaminants to be purged from the hot oil. This must be done with the inlet to the pump blocked off to prevent air from free flowing through the pump. If the pump is operated at an elevated vacuum level, oil will be expelled from the pump and damage will occur.
- If optional secondary traps are used, monitor their condition often and replace them when they are saturated. A new acid trap is off-white and changes color to purple when used up. A new moisture trap is blue and changes color to pink when used up. The solvent trap molecular sieve does not change color when saturated so extra care must be taken to determine when a replacement cartridge should be installed.

Solvent Safety Precautions

CAUTION: Solvents used in the CentriVap Cold Trap may be flammable or hazardous. Use extreme caution and keep sources of ignition away from the solvents. When using flammable or hazardous solvents, both the CentriVap Cold Trap and the vacuum pump should be operated inside a fume hood.

Hazardous materials, such as strong acids or bases, radioactive substances and volatile organics, must be handled carefully and promptly cleaned up if spilled.

Do not store flammable or hazardous solvents within 12 inches (300 mm) of the CentriVap Cold Trap.

IMPORTANT NOTE: The disposal of substances used in connection with this equipment may be governed by various Federal, State or local regulations. All users of this equipment are urged to become familiar with any regulations that apply in the user's area concerning the dumping of waste materials in or upon water, land or air and to comply with such regulations.

Chapter 4:

Maintaining Your CentriVap Cold Trap

Under normal operation, the CentriVap Cold Trap requires little maintenance. The following maintenance schedule is recommended. Before servicing the Cold Trap, disconnect electrical power. Special precautions must be observed if materials used in the CentriVap Cold Trap are known to be hazardous, toxic, radioactive or contaminated with biohazardous. Before servicing, the CentriVap Cold Trap must be suitably decontaminated. Wear appropriate eyewear, gloves and other safety apparel.

As needed:

Before using any cleaning or decontamination method except those recommended by the manufacturer, users should check with the manufacturer that the proposed method will not damage equipment.

1. Clean up all spills; remove liquids from the chamber. Clean or decontaminate all surfaces using agents suitable for the substance spilled.
2. Clean lid and gasket using soft cloth, sponge or chamois and a mild, non-abrasive soap or detergent.
3. Check oil level of the vacuum pump, if applicable. It should be between MIN and MAX.
4. If oil shows cloudiness, particles or discoloration, drain the pump and replace with fresh oil.
5. Utilization of acids requires immediate cleaning and neutralization after a run or physical damage to the collection chamber will result.
6. Check the Cold Trap for condensed or frozen solvents and dispose of appropriately. Completely empty the trap before the next run. The Cold Trap cover is removed by first lifting and rotating the two retainers that secure the lid in place. If solvents are frozen in the glass trap, run it under cold water immediately after operating.

NOTE: IF THE ICE HAS MELTED, THE GLASS TRAP INSERT MUST BE EMPTIED BEFORE THE COLD TRAP IS STARTED AGAIN.

7. If the Glass Trap is used, check to see that the ethanol in the stainless steel trap is free of ice or water. Drain the ethanol and replace it with fresh ethanol.
8. If the media in the cartridge in the optional clear canister has changed color, discard and replace the insert with a new insert. For the radiochemical trap insert, no indicator exists; therefore, it should be discarded after each use. In radioactive applications, the system should be monitored with a Geiger counter.
9. Check the continuity of the protective earth between the ground terminal on the power inlet and a bare metal housing panel. Contact Labconco if there is no continuity.
10. Repair any defects to the surface where the CentriVap Cold Trap is installed.

Monthly:

1. The rubber components on the CentriVap Cold Trap may eventually deteriorate and require replacement. The effective life of rubber parts depends upon both their usage and the surrounding environment. Check all rubber hoses and gaskets and replace any that show signs of hardening, permanent set or deterioration.
2. Using a soft cloth, sponge, or chamois and a mild, non-abrasive soap or detergent, clean the exterior surfaces of the unit. Liquid spray cleaners and polishes may be used on the exterior surfaces. Do not use solvents to remove stains from the exterior surfaces as they may damage the finish.

Annually:

1. Every 12 months, or more often, if the Cold Trap is operated in a dusty environment, the refrigeration system condenser of the Cold Trap should be cleaned. Using a vacuum cleaner with brush attachment, clean the condenser to ensure proper airflow for peak performance. Disconnect power to the Cold Trap prior to removing covers.

Chapter 5:

Accessories for Your CentriVap Cold Trap

The configuration of your CentriVap Cold Trap can be changed to accommodate your needs. You may wish to add a secondary trap to trap vapors exhausted from the vacuum pump. Read this chapter to learn how to:

- Install a chemical trap.
- Install a glass trap in the Cold Trap chamber.

The following accessories are available for the CentriVap Concentrator and Cold Trap System.

PART #	DESCRIPTION
7460900	Clear Canister - Accommodates inserts listed below
7814800	Acid Trap Insert
7814900	Moisture Trap Insert
7995600	Ammonia Trap Insert
7815000	Radiochemical Trap Insert
7815200	Solvent Trap Insert
1472100	Direct Drive Vacuum Pump – 117 liters/minute pumping capacity with gas ballast. Ultimate pressure 1.3×10^{-4} mBar. 115 VAC, 60 Hz, single phase, 4.6 amp.
1467700	Direct Drive Vacuum Pump – 195 liters/minute capacity with gas ballast. Ultimate pressure 1.3×10^{-4} mBar. 115 VAC, 60 Hz, single phase, 7.8 amp.
7739402	Direct Drive Vacuum Pump – 117 liters/minute. Same as 1472100 except 220/208-230 VAC, 50/60 Hz, single phase, 2.4 amp operation.
7739403	Direct Drive Vacuum Pump – 195 liters/minute. Same as 1467700 except 220/208-230 VAC, 50/60 Hz, single phase, 4.0 amp operation.
7393000	Diaphragm Vacuum Pump – Corrosion resistant, 115V, 50/60 Hz, 3.5 amps, single phase, 82 liters/minute, < 2 mBar vacuum.
7393001	Diaphragm Vacuum Pump – Corrosion resistant, 230V, 50/60 Hz, 2.0 amps, single phase, 82 liters/minute at 60Hz, < 2 mBar vacuum.
1473400	Vacuum Pump Exhaust Filter – Installs on pumps PN 1472100, 1467700, 7739402 and 7739403 to eliminate oil mist from the exhaust.
7397700	Two Place Freeze Dry Manifold – Manifold has 1/2" neoprene valves and is used for freeze drying small volume samples.
7307500	Four Place Freeze Dry Manifold – Manifold has 1/2" neoprene valves and is used for freeze drying small volume samples.
7397605	Glass Trap for Cold Trap.
1988000	Vacuum Pump Oil, 1 Liter A molecularly distilled hydrocarbon oil with low vapor pressure. For vacuum pumps 1472100, 7422100, 7739402 and 7739403.
1473400	Pump Exhaust Filter Disposable filter that removes visible oil mist and odor from vacuum pump exhaust. Fits vacuum pumps 1472100 and 7739402.
1473200	Replacement Element, Oil Mist, Pump Exhaust Filter Fits pump exhaust filter 1473400.
1473300	Replacement Element, Odor and Pump Exhaust Filter (package of 5) Fits pump exhaust filter 1473400 or vacuum pumps 1472100 1467700, 7739402, and 7739403.

Installing a Secondary Chemical Trap

An accessory secondary chemical trap is available to protect the vacuum pump and minimize the exhausting of solvents into the atmosphere. It may be attached to either side of the Cold Trap. After selecting the side, remove the two small plastic hole plugs. Attach the bracket to the side of the Cold Trap housing using the screws provided. Attach the hose from the Cold Trap Lid Assembly to the “out” connector of the canister housing. Connect another hose from the remaining fitting on the Secondary Trap to the inlet port on the vacuum pump. Clamp hoses securely. Unscrew the clear bowl of the canister housing from the head. Remove both the upper and lower caps from the filter cartridge and insert the small end of the cartridge into the hole in the center of the head. Reinstall the clear bowl.

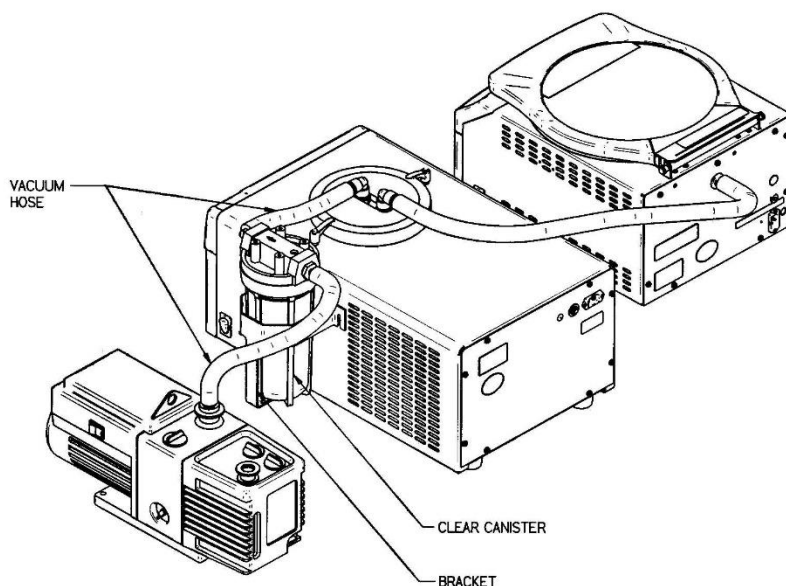

Be sure to use the proper cartridge for your application. When the media in the insert has changed color, discard the insert and replace it with a new insert. For the radiochemical trap insert, no color indicator exists therefore it should be discarded after each use. Use a Geiger counter to monitor the pump exhaust.

NOTE: This radiochemical cartridge does not meet NRC filter design recommendations. After operating, properly dispose of all hazardous materials in compliance with all applicable codes. Labconco is not responsible for improper disposal of any materials.

Installing a Glass Trap in the Cold Trap

An accessory Glass Trap is available for use in the Cold Trap for use when corrosive chemicals are used that could attack the stainless steel chamber of the Cold Trap. Lift and rotate the two lid retainers. Disconnect the hose and remove the Cold Trap Lid Assembly. Attach the hose from the Concentrator to the fitting on the center tube of the Glass Trap and clamp securely. Attach the hose from the vacuum pump or Secondary Trap to the other fitting on the Glass Trap and clamp securely. Be certain that the drain valve is closed. Add approximately 500 ml of ethyl alcohol to the stainless steel trap or enough to insure that the Glass Trap is at least two-thirds immersed. Place the Glass Trap inside the stainless steel trap, lift and rotate the two retainers to hold the Glass Trap in place.

NOTE: After a run, if the ice in the glass trap has melted, the trap must be emptied before the cold trap is started again to prevent it from breaking.

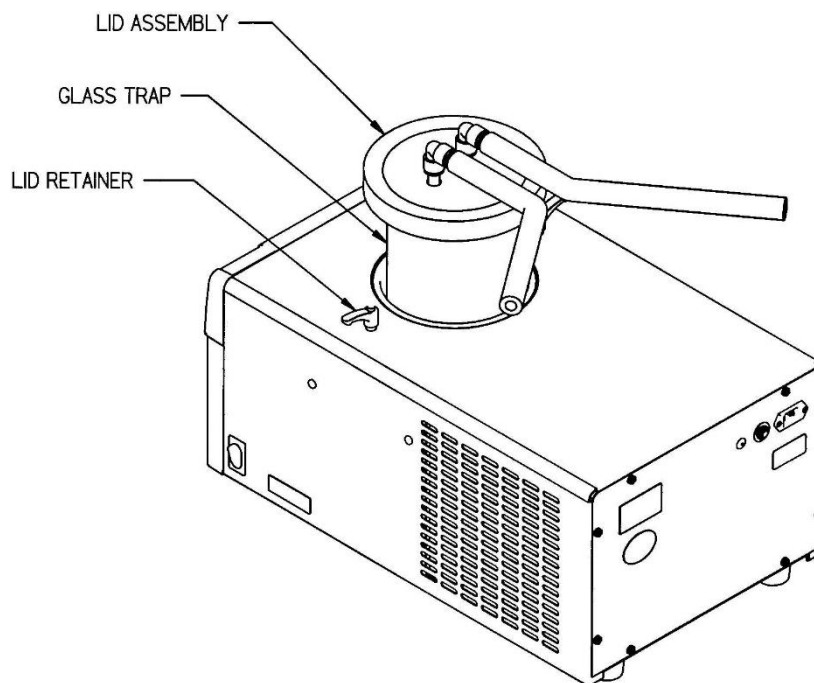

Chapter 6:

Troubleshooting

Refer to the following if your CentriVap Cold Trap fails to operate properly. If the suggested corrective actions do not solve your problem, contact Labconco for additional assistance.

CAUTION: Disconnect power before corrective action is taken.

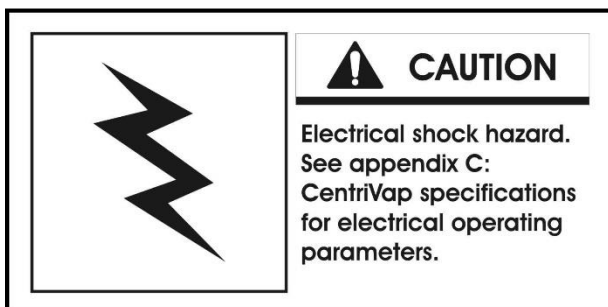

PROBLEM	CAUSE	CORRECTIVE ACTION
Unit will not operate	Unit not connected to electrical power	Connect unit to proper electrical receptacle.
	Circuit breaker blown	Correct electrical problem and reset circuit breaker by pressing button.
Sample odor in lab	Vent hose exhausting into lab area	Redirect hose to fume hood.
Evaporation rate is reduced	Vacuum pump failure	Check pump.
	Obstruction in hose	Remove obstruction or replace hose.
	Lack of adequate vacuum	See below.
No vacuum/poor vacuum	Pump not on	Turn on pump.
	Leaks in lines or connectors or gasket	Locate and repair.
	Foreign material on lid gasket	Clean gasket and lid.

PROBLEM	CAUSE	CORRECTIVE ACTION
No vacuum/poor vacuum (cont.)	Pump is not functioning properly	Check pump by locating vacuum gauge closer to pump and close off rest of system. Check pump oil for cloudiness or particles and change. If pump is faulty, seek authorized service or replace pump.
	Cold Trap lid not seated	Hold lid down until vacuum is initiated.
	Ice formed on Cold Trap lid sealing surface	Defrost and wipe dry.
	Secondary Trap Cannister not fitted properly	Tighten all connections to and from the Secondary Trap Cannister.
	Secondary Trap Insert is spent	Replace with new insert.
Recovery of condensate in Cold Trap is less than normally expected	New Secondary Trap has moisture in it	Run vacuum pump for 24 hours to remove moisture.
	Cold Trap is not ON	Check to make sure switch is ON and condensing unit fan is moving air out of the rear of the cabinet.
Frequent oil change needed in pump	Cold Trap does not cool down	Turn vacuum pump OFF and allow Cold Trap to cool for at least 30 min. to reach temperature. -50°C temperature can be checked with a solvent thermometer or digital thermometer.
	Secondary Trap insert is spent	Change insert often.
	Cold Trap is not emptied after each run and dried	Empty the traps (glass or stainless steel) after each run and replace.
	Vacuum too strong for chemical	Use a Secondary Trap insert and diaphragm pump.

Appendix A:

CentriVap Cold Trap Components

The following pages list components that are available for your CentriVap Cold Trap. The parts shown are the most common replacement parts. If other parts are required, contact Product Service.

CentriVap Cold Trap Components (-50°C Models)

Item	Quantity	Part No.	Description
1	1	7398100	Label
2	1	7394400	Printed Circuit Board
3	1	1302300	Switch
4	1	1327208	Circuit Breaker (115V)
4A	2	1327204	Circuit Breaker (230V)
5	1	1333800	Power Cord Inlet
6	1	7437700	Compressor (115V)
6A	1	7437701	Compressor (230V/50Hz)
6B	1	7734402	Compressor (230/60Hz)
7	1	7936200	Drier
8	1	7387300	Line Assembly
9	1	1360500	Valve
10	1	7464600	Wire Assembly – Ground
11	1	7399700	Lid Assembly
12	2	1554800	Stem Adapter
13	2	1554900	Elbow
14	2	1554700	Stem
15	1	7397606	Lid Assembly for Glass Trap
16	1	7871500	Glass Trap
17	1	1334500	Power Cord 115V (Not Shown)
17A	1	1336100	Power Cord 230V EU (Not Shown)
17B	1	1332600	Power Cord 230V UK (Not Shown)
17C	1	1332700	Power Cord 230V China (Not Shown)
17D	1	1338000	Power Cord 230V US (Not Shown)

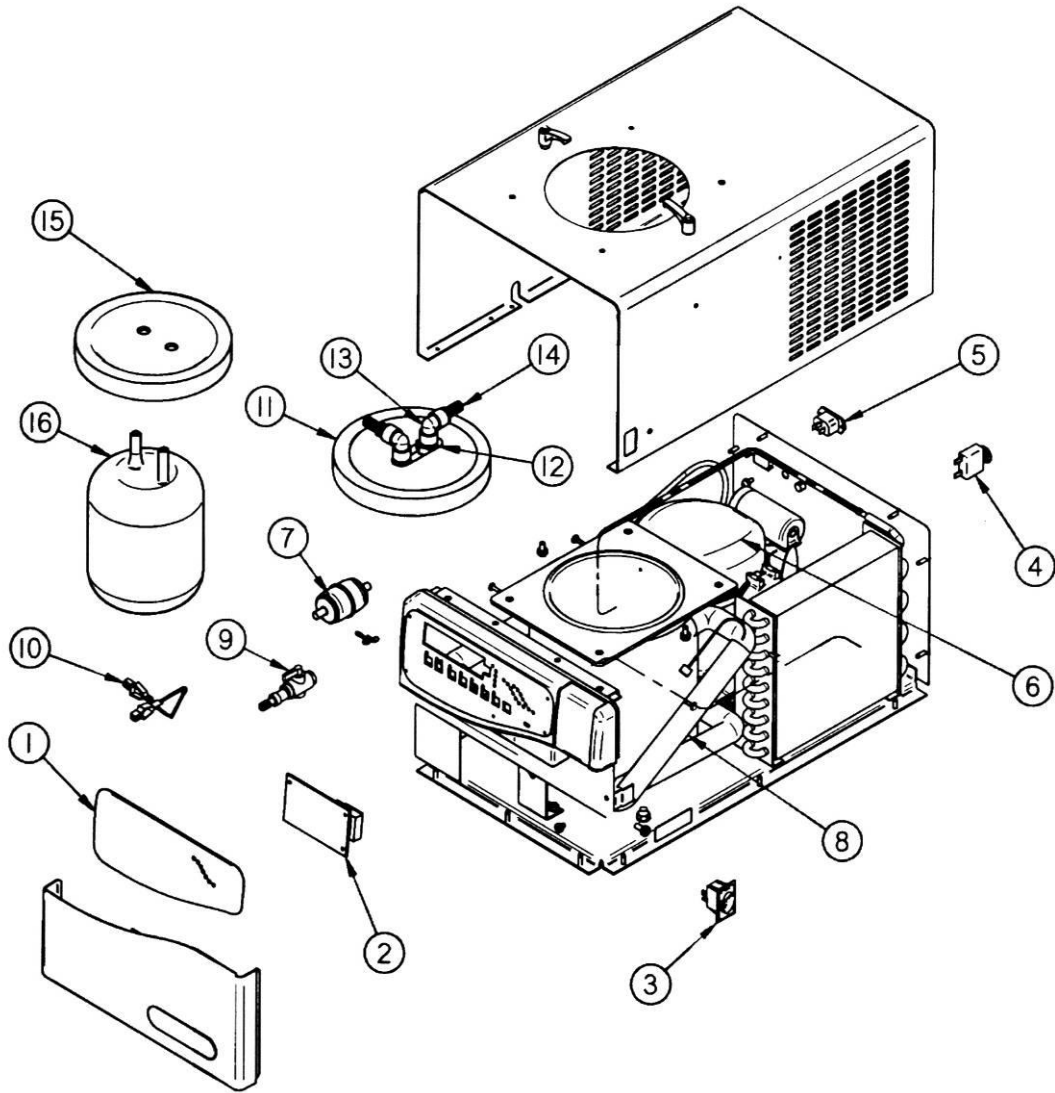

CentriVap Cold Trap Components (-85°C Models)

Item	Quantity	Part No.	Description
1	1	7398100	Label
2	1	7394402	Printed Circuit Board
3	1	1302300	Switch – Power
4	1	7474200	Timer (115V)
4A	1	7474400	Timer (230V)
5	1	7431700	Switch – Pressure
6	1	1360500	Valve
7	1	7464600	Wire Assembly – Ground
8	1	1327207	Circuit Breaker (115V)
8A	2	1327208	Circuit Breaker (230V)
9	2	1548603	Stem Adapter
10	2	1544501	Elbow
11	2	1548101	Stem
12	1	7398900	Insulation – Lid Assembly
13	1	1334500	Power Cord 115V (Not Shown)
13A	1	1336100	Power Cord 230V EU (Not Shown)
13B	1	1332600	Power Cord 230V UK (Not Shown)
13C	1	1332700	Power Cord 230V China (Not Shown)
13D	1	1338000	Power Cord 230V US (Not Shown)
14	1	7871500	Glass Trap
15	1	7397606	Lid Assembly Complete, Glass Trap
16	1	7397608	Insulation – Glass Trap
17	2	7591800	Compressor 115V
17A	2	7591801	Compressor 230V/50Hz
17B	2	7591802	Compressor 230V/60Hz
18	1	7399700	Cover Assembly Complete, Acrylic

Appendix A: CentriVap Cold Trap Components

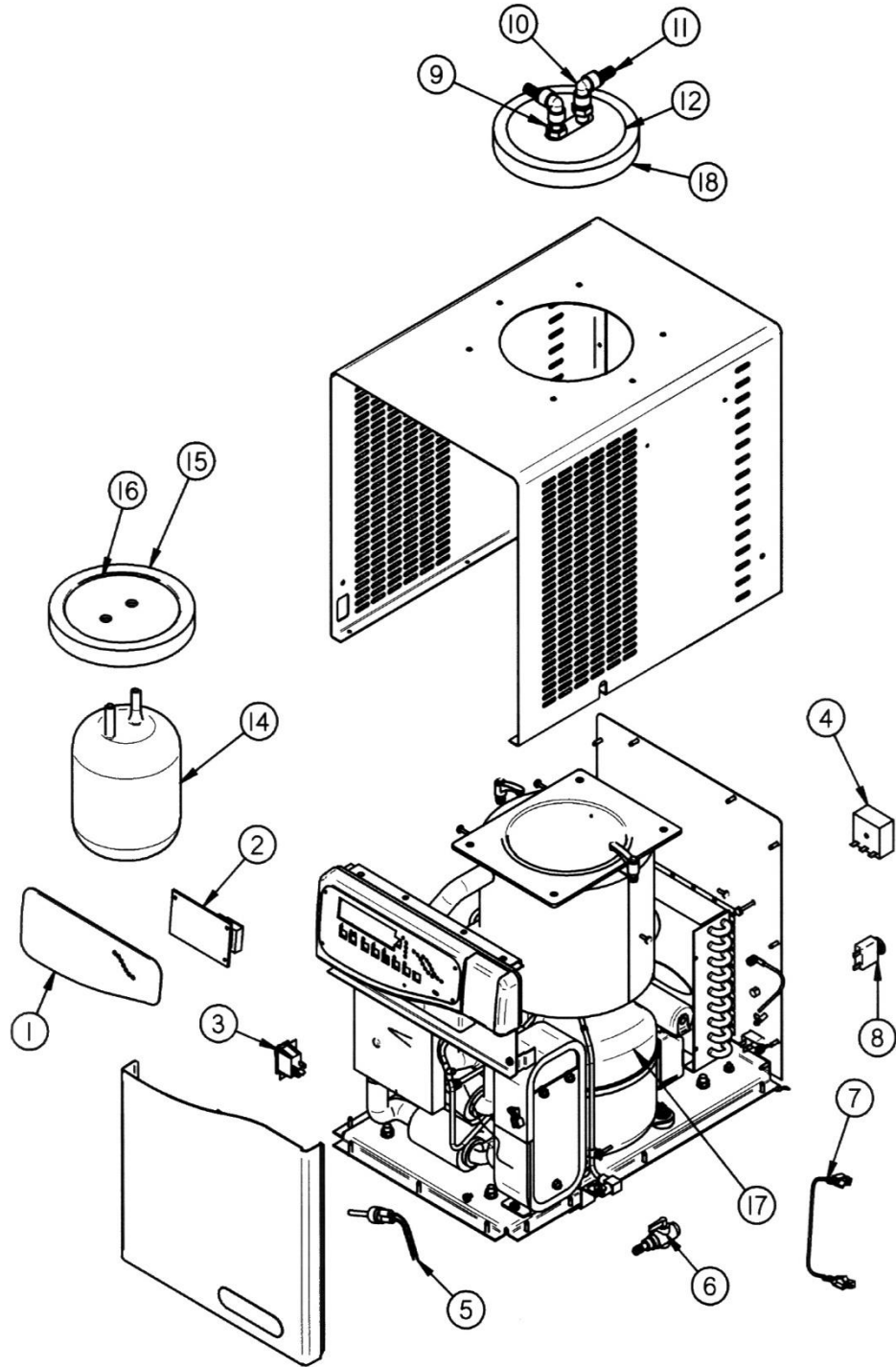

CentriVap Cold Trap Components (-105°C Models)

Item	Quantity	Part No.	Description
1	1	7398100	Label
2	1	7394402	Printed Circuit Board
3	1	1302300	Switch – Power
4	1	7474200	Timer (115V)
4A	1	7474400	Timer (230V)
5	1	7431700	Switch – Pressure
6	1	1360500	Valve
7	1	7464600	Wire Assembly – Ground
8	1	1289315	Circuit Breaker (115V)
8A	2	1289308	Circuit Breaker (230V)
9	2	1548603	Stem Adapter
10	2	1544501	Elbow
11	2	1548101	Stem
12	1	7398900	Insulation – Lid Assembly
13	1	1336400	Power Cord 115V (Not Shown)
13A	1	1336500	Power Cord 230V EU (Not Shown)
13B	1	1332601	Power Cord 230V UK (Not Shown)
13C	1	1332701	Power Cord 230V China (Not Shown)
13D	1	1342100	Power Cord 230V US (Not Shown)
14	1	7871500	Glass Trap
15	1	7397606	Lid Assembly Complete, Glass Trap
16	1	7397608	Insulation – Glass Trap
17	2	7591800	Compressor 115V
17A	2	7591801	Compressor 230V/50Hz
17B	2	7591802	Compressor 230V/60Hz
18	1	7399700	Cover Assembly Complete, Acrylic

Appendix A: CentriVap Cold Trap Components

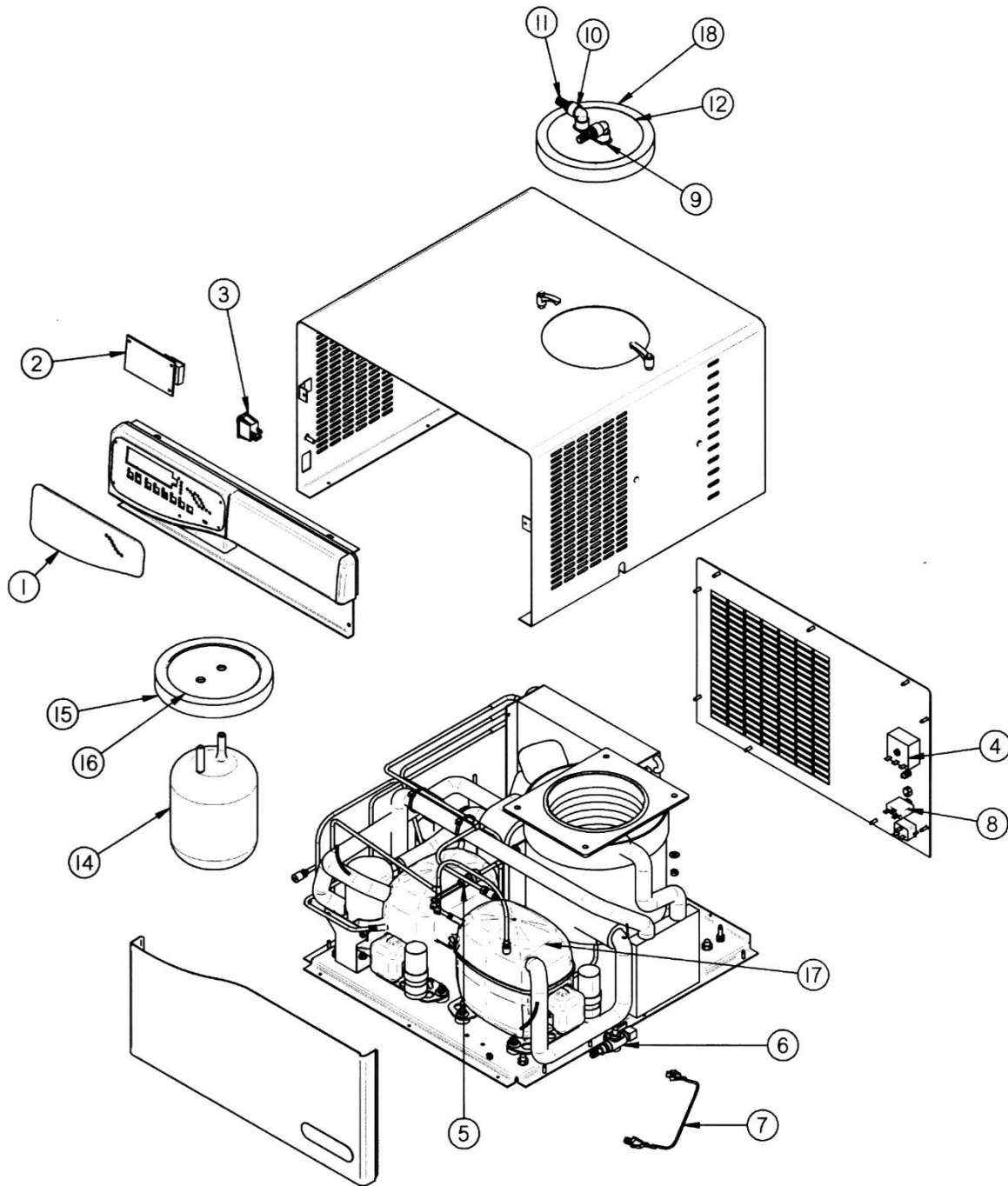

Appendix B: CentriVap Cold Trap Dimensions

CentriVap Cold Trap (-50°C Models)

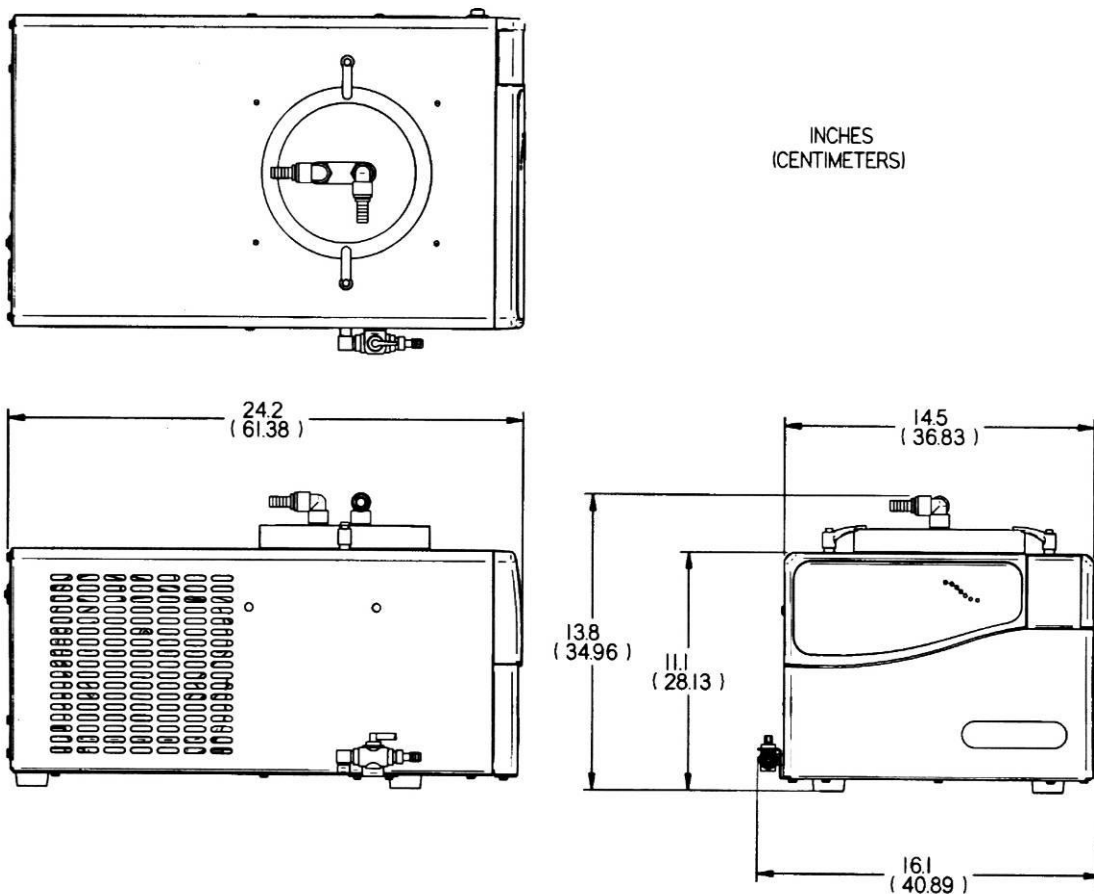

CentriVap Cold Trap (-85°C Models)

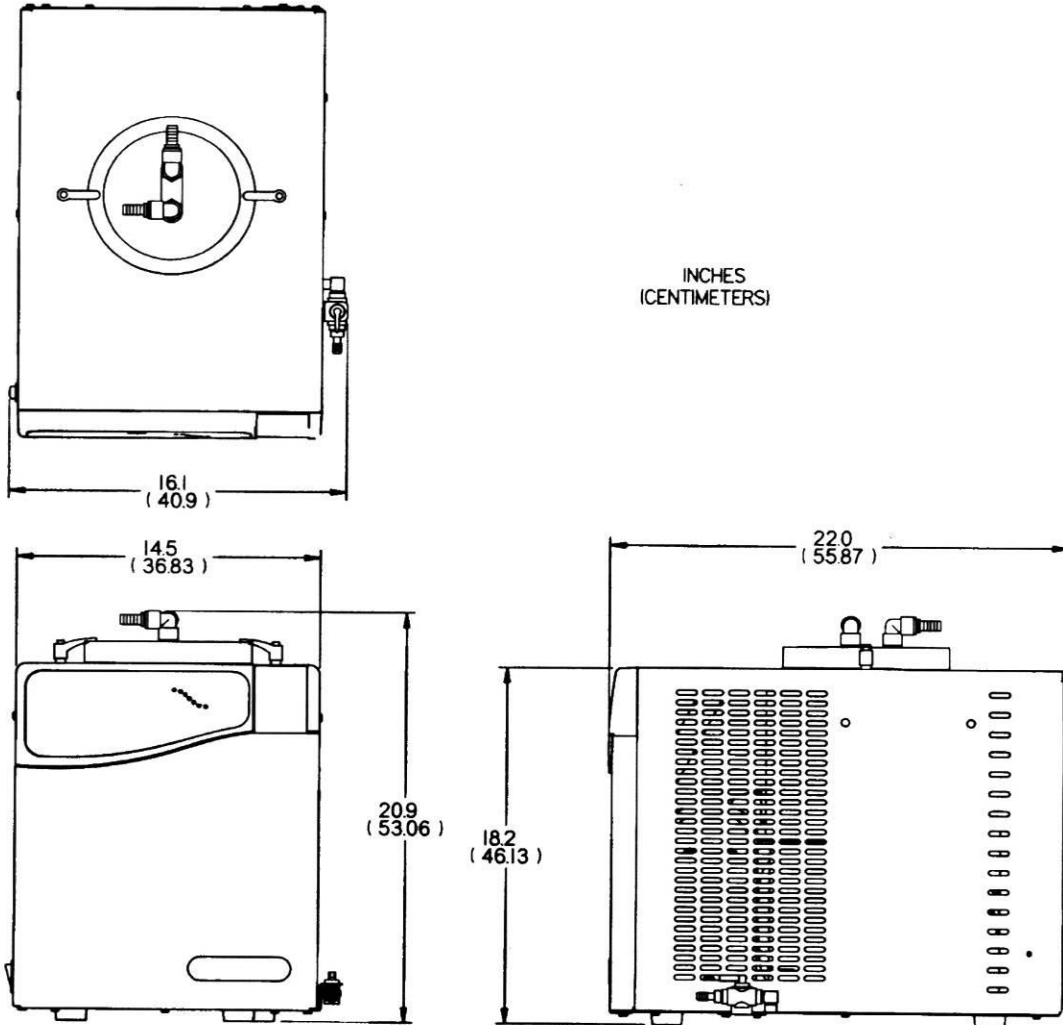

CentriVap Cold Trap (-105°C Models)

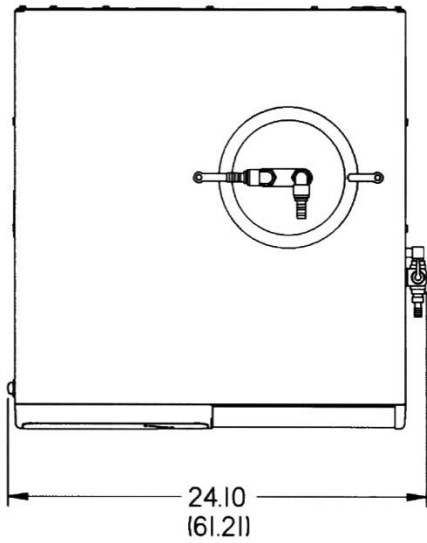

INCHES
(CENTIMETERS)

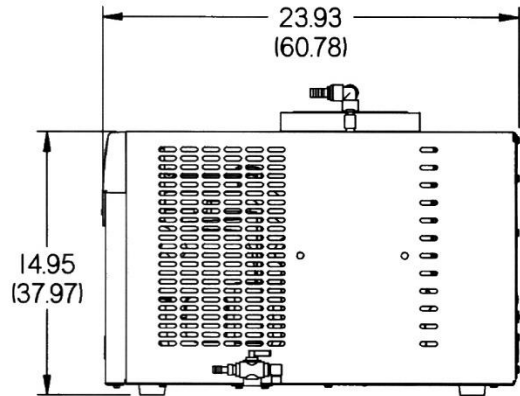
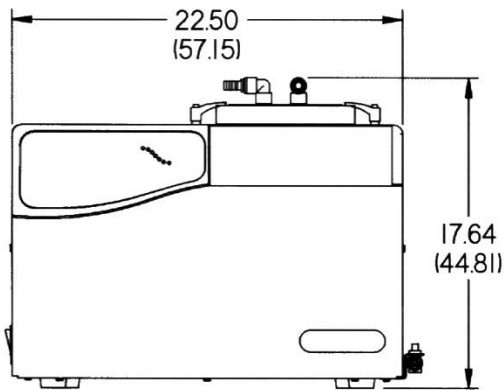

Appendix C:

CentriVap Cold Trap

Specifications

This Appendix contains technical information about the CentriVap Cold Trap including specifications and environmental operating conditions.

Electrical Specifications

- Nominal amperage for 115V/60Hz Cold Trap (-50° Models): 6.0A.
- Nominal amperage for 230V 50/60Hz Cold Trap (-50° Models): 2.5A.
- Nominal amperage for 115V/60Hz Cold Trap (-85° Models): 10.0A.
- Nominal amperage for 230V 50/60Hz Cold Trap (-85° Models): 5.1A.
- Nominal amperage for 115V 60Hz Cold Trap (-105°C Models): 13A.
- Nominal amperage for 230V 50/60Hz Cold Trap (-105°C Models): 7A.
- Phase: Single

Environmental Conditions

- Indoor use only.
- Maximum altitude: 6562 feet (2000 meters).
- Ambient temperature range: 41° to 104°F (5° to 40°C).
- Maximum relative humidity: 80% for temperatures up to 88°F (31°C), decreasing linearly to 50% relative humidity at 104°F (40°C).
- Main supply voltage fluctuations not to exceed $\pm 10\%$ of the nominal voltage.
- Transient overvoltages according to Installation Categories II (Overvoltage Categories per IEC 1010). Temporary voltage spikes on the AC input line that may be as high as 1500V for 115V models and 2500V for 230V models are allowed.
- Used in an environment of Pollution degrees 2 (i.e., where normally only non-conductive atmospheres are present). Occasionally, however, a temporary conductivity caused by condensation must be expected, in accordance with IEC 664.