



LABCONCO CORPORATION

8811 Prospect Avenue
Kansas City, MO 64132
(800) 821-5525, (816) 333-8811
(816) 363-0130 fax
labconco@labconco.com

User's Manual

RapidVap[®] Vertex Evaporator

Models

73200 Series

To receive important product updates,
complete your product registration card
online at register.labconco.com

Please read the User's Manual before operating the equipment.

Copyright © 2017 Labconco Corporation. The information contained in this manual and the accompanying products are copyrighted and all rights reserved by Labconco Corporation. Labconco Corporation reserves the right to make periodic design changes without obligation to notify any person or entity of such change.

Warranty

Labconco Corporation provides a warranty to the original buyer for the repair or replacement of parts and reasonable labor as a result of normal and proper use of the equipment with compatible chemicals. Broken glassware and maintenance items, such as filters, gaskets, light bulbs, finishes and lubrication are not warranted. Excluded from warranty are products with improper installation, erratic electrical or utility supply, unauthorized repair and products used with incompatible chemicals.

The warranty for RapidVap® Vertex™ Evaporators will expire one year from date of installation or two years from date of shipment from Labconco, whichever is sooner. Warranty is non-transferable and only applies to the owner (organization) of record.

Buyer is exclusively responsible for the set-up, installation, verification, decontamination or calibration of equipment. This limited warranty covers parts and labor, but not transportation and insurance charges. If the failure is determined to be covered under this warranty, the dealer or Labconco Corporation will authorize repair or replacement of all defective parts to restore the unit to operation. Repairs may be completed by 3rd party service agents approved by Labconco Corporation. Labconco Corporation reserves the rights to limit this warranty based on a service agent's travel, working hours, the site's entry restrictions and unobstructed access to serviceable components of the product.

Under no circumstances shall Labconco Corporation be liable for indirect, consequential, or special damages of any kind. This warranty is exclusive and in lieu of all other warranties whether oral, or implied.

Returned or Damaged Goods

Do not return goods without the prior authorization from Labconco. Unauthorized returns will not be accepted. If your shipment was damaged in transit, you must file a claim directly with the freight carrier. Labconco Corporation and its dealers are not responsible for shipping damages.

The United States Interstate Commerce Commission rules require that claims be filed with the delivery carrier within fifteen (15) days of delivery.

Limitation of Liability

The disposal and/or emission of substances used in connection with this equipment may be governed by various federal, state, or local regulations. All users of this equipment are required to become familiar with any regulations that apply in the user's area concerning the dumping of waste materials in or upon water, land, or air and to comply with such regulations. Labconco Corporation is held harmless with respect to user's compliance with such regulations.

Contacting Labconco Corporation

If you have questions that are not addressed in this manual, or if you need technical assistance, contact Labconco's Customer Service Department or Labconco's Product Service Department at 1-800-821-5525 or 1-816-333-8811, between the hours of 7:30 a.m. and 5:30 p.m., Central Standard Time.

TABLE OF CONTENTS

CHAPTER 1: INTRODUCTION	1
Typographical Conventions	2
CHAPTER 2: PREREQUISITES	3
Electrical Requirements	4
Location and Exhaust Requirements	4
Nitrogen Supply Requirements	4
Space Requirements	4
Tools Required	4
CHAPTER 3: GETTING STARTED	5
Unpacking Your RapidVap Vertex Evaporator	6
RapidVap Vertex Evaporator Components	6
Setting Up Your RapidVap Vertex Evaporator	8
Sample Block	8
Nitrogen Gas Connection	9
Exhaust Port	9
Electrical Connection	10
Chemical Attack on RapidVap Vertex Evaporator Components	10
Solvent Safety Precautions	11
CHAPTER 4: USING YOUR RAPIDVAP VERTEX EVAPORATOR	13
Planning	14
Loading Glassware into the RapidVap Vertex Evaporator	14
RapidVap Vertex Evaporator Controls	14
Operating the RapidVap Vertex Evaporator Controls	15
Operating the RapidVap Vertex Evaporator	19
Operational Notes	20
Interrupting a Cycle After it has Begun	20
CHAPTER 5: MAINTAINING YOUR RAPIDVAP VERTEX EVAPORATOR	21

CHAPTER 6: TROUBLESHOOTING	22
APPENDIX A: RAPIDVAP VERTEX EVAPORATOR COMPONENTS	25
APPENDIX B: RAPIDVAP VERTEX EVAPORATOR DIMENSIONS	28
APPENDIX C: RAPIDVAP VERTEX EVAPORATOR SPECIFICATIONS	29
Evaporation Rates	31
APPENDIX D: RAPIDVAP VERTEX EVAPORATOR ACCESSORIES	32

CHAPTER 1

INTRODUCTION

Congratulations on your purchase of a Labconco RapidVap Vertex Evaporator. Models are available for operation on 115V or 230V. Superior evaporation rates are achieved by the unique blending of several gentle forces on the sample. The vials containing the sample are held at an angle to increase the surface area of the sample thereby increasing the evaporation rate. A precisely controlled amount of thermal energy can be supplied to the sample to heat it. Finally, a stream of nitrogen or dry gas is directed downward onto the surface of the sample. This reduces the partial pressure directly over the liquid to speed evaporation and helps remove the solvent as it evaporates. In summary, the RapidVap Vertex Evaporator performance is maximized by increasing the sample's surface area, increasing temperature and directing gas over the sample. The microprocessor provides excellent regulation of the heater and reproducibility of protocols.

Typographical Conventions

Recognizing the following typographical conventions will help you understand and use this manual:

- Book, chapter, and section titles are shown in italic type (e.g., *Chapter 3: Getting Started*).
- Steps required to perform a task are presented in a numbered format.
- Comments located in the margins provide suggestions, reminders, and references.



- Critical information is presented in boldface type in paragraphs that are preceded by the exclamation icon. Failure to comply with the information following an exclamation icon may result in injury to the user or permanent damage to your RapidVap Vertex Evaporator.

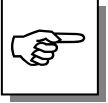

- Important information is presented in capitalized type in paragraphs that are preceded by the pointer icon. It is imperative that the information contained in these paragraphs be thoroughly read and understood by the user.

CHAPTER 2

PREREQUISITES

Before you install your RapidVap Vertex Evaporator, you need to prepare your site for installation. Carefully examine the location where you intend to install your RapidVap Vertex Evaporator. You must be certain that the area is level and of solid construction. In addition, an exhaust means must be provided and a source of nitrogen or dry gas must be available. An electrical source must be located near the installation site.

Carefully read this chapter to learn:

- the electrical supply requirements.
- the exhaust requirements.
- the nitrogen supply requirements.

Refer to *Appendix C: RapidVap Vertex Evaporator Specifications* for complete RapidVap Vertex Evaporator electrical and environmental conditions, specifications and requirements.

Electrical Requirements

A dedicated electrical outlet is required. Minimum requirements for an outlet is a 15 Amp circuit breaker or fuse for models rated at 115V (60 Hz) or an 8 Amp circuit breaker or fuse is required for 230V (50/60 Hz) models. 115V models are equipped with a 15 Amp NEMA 5-15P plug. 230V models are available with a NEMA 6-15P plug for use in the United States, a PS 1363 plug for use in the United Kingdom, a CEE 7/7 plug for use in Europe or a CHI-10P plug for use in China. It may be necessary to remove the plug and install a different plug to match the available receptacle if one of these models does not meet your needs.

Location and Exhaust Requirements



The RapidVap Vertex Evaporator must be located within a fume hood if hazardous or flammable solvents are used. In all cases, regardless of the solvent used, it is recommended that the exhaust hose is vented into a fume hood or other laboratory ventilation device.

Nitrogen Supply Requirements

The 1/4" I.D. hose on the rear of the RapidVap Vertex Evaporator should be attached to a regulated source of nitrogen or other suitable gas. Pressure must NOT exceed 80 psi. The nitrogen supply must be capable of 6.5 CFM flow rate. A suitable barb or compression fitting must be supplied by the user.

Space Requirements

Refer to *Appendix B: RapidVap Vertex Evaporator Dimensions* for dimensional drawings of the RapidVap Vertex Evaporator.

Tools Required

Common hand tools are required to set up the RapidVap Vertex Evaporator. A screwdriver or 5/16" socket is needed to attach hose clamps. A tubing cutter or knife is needed to shorten exhaust hoses.

CHAPTER 3

GETTING STARTED

Now that the site for your RapidVap Vertex Evaporator is properly prepared, you are ready to unpack, inspect, install, and test your RapidVap Vertex Evaporator. Read this chapter to learn how to:

- unpack and move your RapidVap Vertex Evaporator.
- set up your RapidVap Vertex Evaporator.
- connect the nitrogen source to your RapidVap Vertex Evaporator.
- connect the electrical supply source to your RapidVap Vertex Evaporator.
- properly exhaust your RapidVap Vertex Evaporator.
- solvent safety precautions.



The RapidVap Vertex Evaporator weighs over 35 lbs. (16 Kg). The carton allows for lifting with a mechanical lift truck or hand truck.

Unpacking Your RapidVap Vertex Evaporator

Carefully unpack your RapidVap Vertex Evaporator and inspect it for damage that may have occurred in transit. If your RapidVap Vertex Evaporator is damaged, notify the delivery carrier immediately and retain the entire shipment intact for inspection by the carrier.

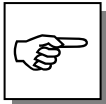

DO NOT RETURN GOODS WITHOUT THE PRIOR AUTHORIZATION OF LABCONCO. UNAUTHORIZED RETURNS WILL NOT BE ACCEPTED.

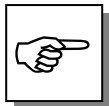

IF YOUR RAPIDVAP VERTEX EVAPORATOR WAS DAMAGED IN TRANSIT, YOU MUST FILE A CLAIM DIRECTLY WITH THE FREIGHT CARRIER. LABCONCO CORPORATION AND ITS DEALERS ARE NOT RESPONSIBLE FOR SHIPPING DAMAGES.

The United States Interstate Commerce Commission rules require that claims be filed with the delivery carrier within fifteen (15) days of delivery.

Do not discard the carton or packing material for your RapidVap Vertex Evaporator until you have checked all of the components and installed and tested the RapidVap Vertex Evaporator.

RapidVap Vertex Evaporator Components

Locate the model of RapidVap Vertex Evaporator you received in the following table. Verify that the components listed are present and undamaged.

Catalog #	Description
7320020	RapidVap Vertex Evaporator – 115V

Plus the Following:

Part #	Component Description
7913100	Exhaust Hose
1966000	Clamp
1334500	Power Cord NEMA 5-15P
7324400	User's Manual
1533301	Tubing

Catalog #	Description
7320030	RapidVap Vertex Evaporator – 230V EU

Plus the Following:

Part #	Component Description
7913100	Exhaust Hose
1966000	Clamp
1336100	Power Cord CEE 7/7
7324400	User's Manual
1533301	Tubing

Catalog #	Description
7320035	RapidVap Vertex Evaporator – 230V UK

Plus the Following:

Part #	Component Description
7913100	Exhaust Hose
1966000	Clamp
1332600	Power Cord PS 1363
7324400	User's Manual
1533301	Tubing

Catalog #	Description
7320037	RapidVap Vertex Evaporator – 230V China

Plus the Following:

Part #	Component Description
7913100	Exhaust Hose
1966000	Clamp
1332700	Power Cord CHI-10P
7324400	User's Manual
1533301	Tubing

Catalog #	Description
7320040	RapidVap Vertex Evaporator – 230V US

Plus the Following:

Part #	Component Description
7913100	Exhaust Hose
1966000	Clamp
1338000	Power Cord NEMA 6-15P
7324400	User's Manual
1533301	Tubing

Since users' preference of sample size varies, the sample holding block is not included with the RapidVap Vertex Evaporator. The correct size block must be selected and ordered separately. Refer to *Appendix D: RapidVap Vertex Evaporator Accessories* for block selection.

If you do not receive one or more of the components listed for your RapidVap Vertex Evaporator, or if any of the components are damaged, contact Labconco Corporation immediately for further instructions.

Setting Up Your RapidVap Vertex Evaporator

After you verify the RapidVap Vertex Evaporator components, move your RapidVap Vertex Evaporator to the location where you want to install it. Then, follow the steps listed below.

Sample Block

The RapidVap Vertex Evaporator was shipped without the sample block installed. See Appendix D for available blocks. Vials must be snug in the holes in the block. Select the appropriate block to fit the vials that will be used. Make certain that the bottom of the chamber is clean and free of debris. The sample block slides in on the two guides on the front and **MUST** rest securely on the bottom. Make certain that the small .21" dia. temperature sensor hole is in the upper left hand corner. Placing the block in the chamber improperly will effect performance. Insert the tubular temperature sensor into the .21" dia. hole to monitor upper block temperature. The actual sample temperature may be monitored throughout a run by placing the sensor directly into a sample vial.

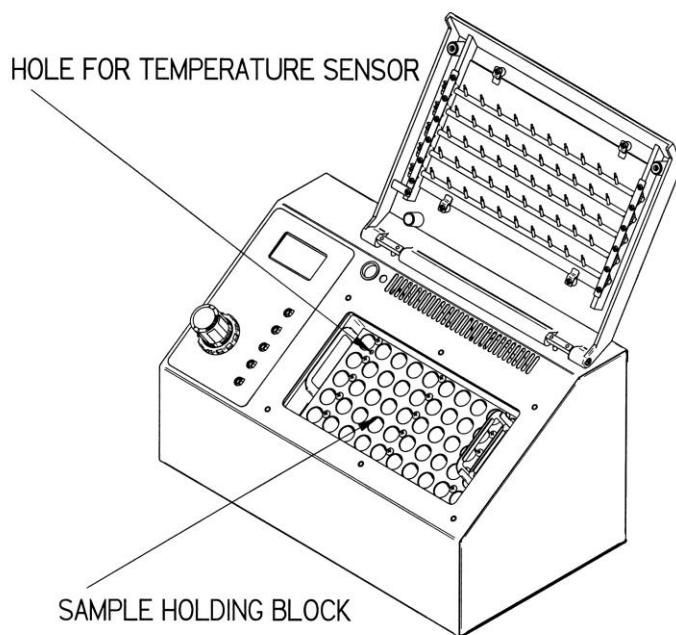

Nitrogen Gas Connection

Mark the gas supply hose 3/4" (19 mm) from the end and push the hose into the fitting in the back of the RapidVap Vertex Evaporator. Attach the other end of the hose to user supplied nitrogen supply.

OPERATION OF QUICK CONNECT FITTINGS

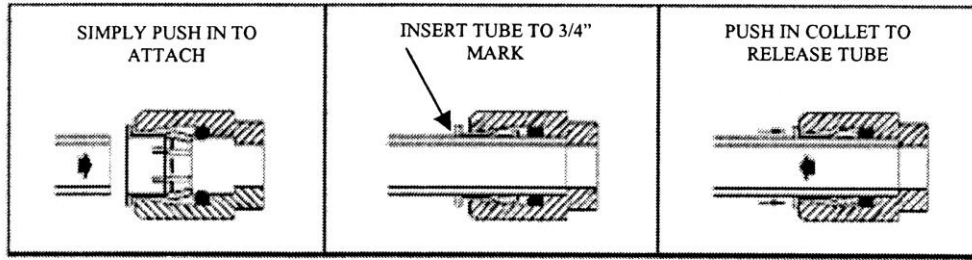

PUSHING TUBE IN BEFORE
PULLING IT OUT HELPS TO
RELEASE TUBE

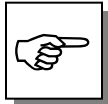

THE NITROGEN SUPPLY PRESSURE MUST NEVER BE ALLOWED TO EXCEED 80 PSI (345 KPA).

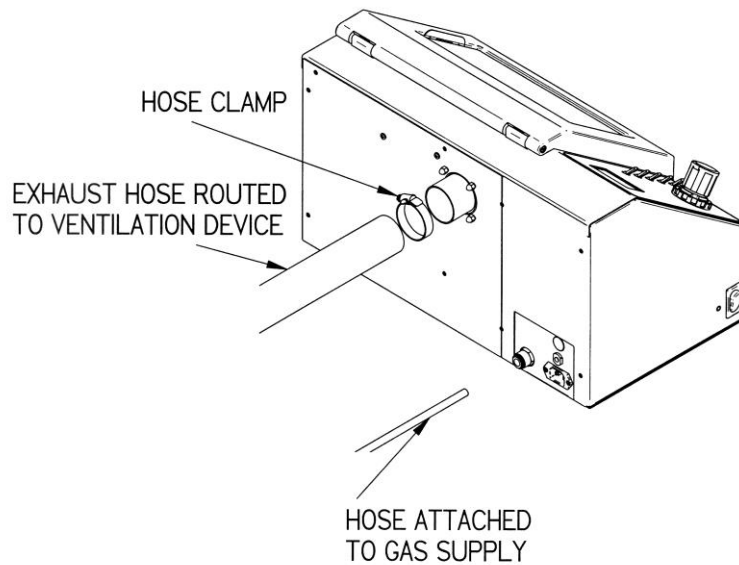

Exhaust Port

If the RapidVap Vertex Evaporator is not located in a fume hood, attach one end of the two inch diameter venting hose that is supplied with the RapidVap Vertex Evaporator to the exhaust port on the rear of the unit. Clamp securely. Route the other end to a fume hood or other laboratory ventilation device.

Electrical Connection

Plug the power cord into the receptacle on the back of the RapidVap Vertex Evaporator and plug the other end into a suitable wall power receptacle.

Chemical Attack on RapidVap Vertex Evaporator Components

Your RapidVap Vertex Evaporator is designed to be chemical resistant to most compounds that are commonly used in the concentration processes that are performed in it. However, by necessity, the RapidVap Vertex Evaporator is comprised of a number of different materials, some of which may be attacked and degraded by certain chemicals. The degree of degradation is obviously dependent on the concentration and duration of exposure. Some of the major components of the RapidVap Vertex Evaporator that are susceptible to degradation are as follows:

COMPONENT	MATERIAL	Acids							Bases		Solvents												
		Acetic Acid 20%	Boric Acid	Formic Acid	Hydrobromic Acid 20%	Hydrochloric Acid 20%	Nitric Acid 20%	Sulfuric Acid 10%	Trifluoroacetic Acid (TFA)	Ammonium Hydroxide	Potassium Hydroxide	Acetone	Acetonitrile	Chloroform	Dimethyl Formamide	Dimethyl Sulfoxide (DMSO)	Ethanol	Ethyl Acetate	Hexanes	Isopropanol	Methylene Chloride	Toluene	
Elbow N2	Polyamid (Nylon)	D		D	D	D	D	D	D	C											D	C	
Blower Impeller	Polyamid (Nylon)	D		D	D	D	D	D	D	C											D	C	
Blower Housing	Polypropylene												C										C
Exhaust Hose	Polyethylene						C					C	C				C	C			C	C	
N2 Supply Hoses	Polyethylene						C					C	C				C	C			C	C	
Block Guides	UMHW Polyethylene						C					C	C				C	C			C	C	
Window Seal	PVC	D		C			D		D			D	D	D	D	C	D	D			D	D	
Lid	Epoxy Coated Alum.			C					D				C	D									
Chamber & Block	Aluminum		D		D	D	D	D		D													C
Nozzle N2	Stainless Steel				D	D		D															
Exhaust Fitting	Stainless Steel				D	D		D															
Ducting	Epoxy Coated Steel			C					D				C	D									
Window	Glass																						

C- Moderate Degradation- Questionable Use

D- Severe Degradation-Infrequent use recommended-immediate thorough cleaning required

- Glass lids are suitable for use with all common compounds.

When using compounds in the RapidVap Vertex Evaporator that are hostile to the materials of construction, it is imperative that the equipment is properly maintained.

- After each run, clean up all residues, spills, and materials that might have splashed in the chamber using agents suitable for the substance involved.

With prudent maintenance your RapidVap Vertex Evaporator will provide many years of service. Warranty on the affected parts will be void if maintenance has obviously been neglected. If you have questions about using specific compounds in your RapidVap Vertex Evaporator, contact Labconco Technical Service at 1-800-821-5525 or 816-333-8811 or e-mail labconco@labconco.com.

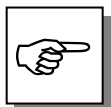

Safety Precautions

The RapidVap Vertex Evaporator is not classified as “explosion proof.” It has been designed with safety as a primary consideration and should be used in a prudent manner using “good laboratory practices.” It has been designed for use with compounds as described in the United States National Electrical Code Class I, Group D. The block that holds the sample tubes may be programmed to run as hot as 100°C, however, the heater element may normally run at 135°C. A thermal fuse limits the heater to a maximum temperature of 152°C. It is important that the solvents used are compatible with these temperatures.



Do not evaporate solvents that have an autoignition temperature below 180°C. Do not evaporate solvents that are classified as Group A, B, or C by the National Electrical Code. Evaporate only non-flammable or Group D solvents with autoignition temperatures 180°C or above. Use of other compounds could cause an explosion.

Solvents used in the RapidVap Vertex Evaporator may be flammable or hazardous. Use extreme caution and keep sources of ignition away from the solvents. When using flammable or hazardous solvents, the RapidVap Vertex Evaporator should be operated inside a fume hood.

If a sample is spilled in the chamber it must immediately be cleaned up.

Hazardous materials such as strong acids or bases, radioactive substances and volatile organics, must be handled carefully and promptly cleaned up if spilled.

Several components of the RapidVap Vertex Evaporator which are located inside the chamber are made of stainless steel or aluminum which can be attacked by acids. Use of acids such as trifluoroacetic acid can result in degradation of the product. Use care when using aggressive liquids which can damage the RapidVap Vertex Evaporator and thoroughly clean the RapidVap Vertex Evaporator after each use. Contact Labconco before evaporating acids.

WARNING: The disposal of substances used in connection with this equipment may be governed by various Federal, State or local regulations. All users of this equipment are urged to become familiar with any regulations that apply in the user's area concerning the dumping of waste materials in or upon water, land or air and to comply with such regulations.

When lifting this product, use at least two (2) persons and always use safe lifting practices.

Do **NOT** use a detachable power cord that is not adequately rated for product.

Always disconnect power from outlet before beginning service operations.

Do not damage internal wiring or other components while service panels are removed. If internal wiring or components are damaged, do not restore power, contact Labconco's Product Service Department immediately.

Wear all required Personnel Protective Equipment (PPE) during service operations. At a minimum, this includes: eye protection, breathing protection, skin protection. Do not wear loose fitting clothes that can catch on internal surfaces. **After service, verify safe state of use before using the product. Contact Labconco's Product Service Department for questions on determining safe state of this product.**

Verify protective earth ground continuity before using equipment.

No special ventilation requirements.

No hazards exist for: explosion, implosion, or release of toxic or flammable gases arising from the materials being heated.

No Heat Transfer Media is required for the normal operation of this equipment.

Cleaning solutions that do not contain chlorine-based disinfectants (such as Bleach or hypochlorites) may be safely used on this equipment.

If there is any doubt about the compatibility of decontamination or cleaning agents, contact Labconco's Product Service Department.

CHAPTER 4

USING YOUR RAPIDVAP VERTEX EVAPORATOR

After your RapidVap Vertex Evaporator has been installed as detailed in *Chapter 3: Getting Started*, you are ready to begin using your RapidVap Vertex Evaporator. Read this chapter to learn how to:

- set operating parameters.
- operate the controls.
- properly select and position glassware inside your RapidVap Vertex Evaporator.
- understand the display.
- interrupt a cycle after it has begun.



Do not use the RapidVap Vertex Evaporator in a manner not specified by the manufacturer (refer to *Appendix C: RapidVap Vertex Evaporator Specifications*). The electrical protection properties of the RapidVap Vertex Evaporator may be impaired if the RapidVap Vertex Evaporator is used inappropriately.

Planning

Thoroughly understand procedures and the equipment operation prior to beginning work. The unique performance of the RapidVap Vertex Evaporator is dependent upon the proper balance of heat and nitrogen flow. If the proper balance is not established, it is possible to damage or lose a portion of the sample. Therefore, if you are unfamiliar with the RapidVap Vertex Evaporator or are attempting a new protocol, it may be helpful to make a trial run that is void of the sample you are attempting to concentrate.

Select the size of the sample tube so it is compatible with the block. Tubes should not be loose in the block. Blocks are available with holes for various size tubes.

Loading Glassware Into the RapidVap Vertex Evaporator

There are 5 control valves that control nitrogen to the 5 horizontal rows of nozzles. Samples should be positioned in complete rows as much as possible. This will minimize the number of rows of nozzles and reduce gas consumption.

RapidVap Vertex Evaporator Controls

The control panel for the RapidVap Vertex Evaporator is shown below with a description about their function.

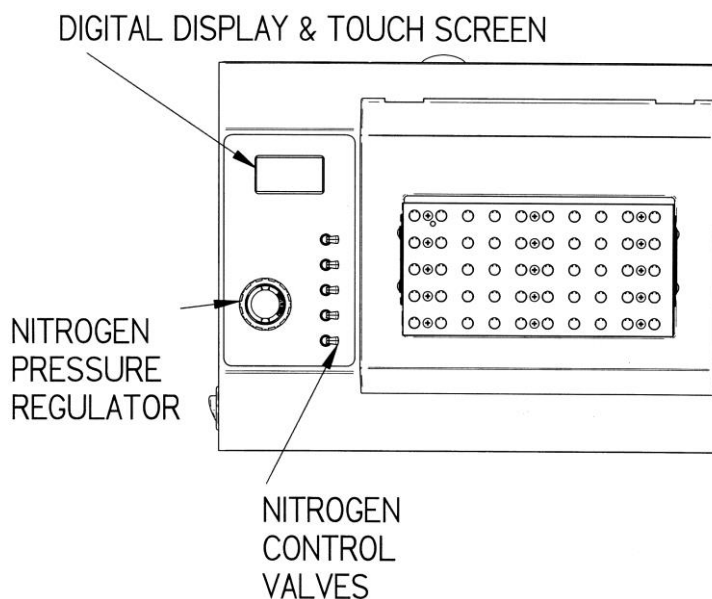

Nitrogen Control Valves – Used to turn nitrogen flow ON or OFF to the nozzles above the sample vials. The top valve controls the 10 nozzles on the top row. The second valve controls the second row of 10 nozzles. The third valve controls the middle row of 10 nozzles. The fourth valve controls the fourth row of 10 nozzles. The bottom valve controls the bottom row of 10 nozzles. Push the lever to the right to turn nitrogen flow ON.

Nitrogen Pressure Regulator – Used to adjust the gas pressure and gas flow rate to the nozzles. To adjust the gas pressure to the nozzles, the gas supply must be connected. Open all of the control valves that will be used during the run. Turn the unit ON and press Run, the main gas supply valve will open. Pull the knob of the Pressure Regulator out and rotate the knob clockwise to increase pressure, counter clockwise to decrease the pressure. The operating pressure is displayed on the knob. Once the pressure is set push the regulator knob in and press Stop.

The pressure can be adjusted at any time during the run. Also note that opening or closing any of the Nitrogen Control Valves without adjusting the pressure will change the flow rate at each nozzle.

The flow rate of gas is approximately 1 cfm (28.3 L/min) per row of 10 nozzles when pressure is set at 24 PSI (165 KPA).

Digital Display – The touch screen LCD is used to control run time and temperature, preheat temperature and other functions as described below.

Operating the RapidVap Vertex Evaporator Controls

When the power switch on the left hand side is turned ON the opening display will show:

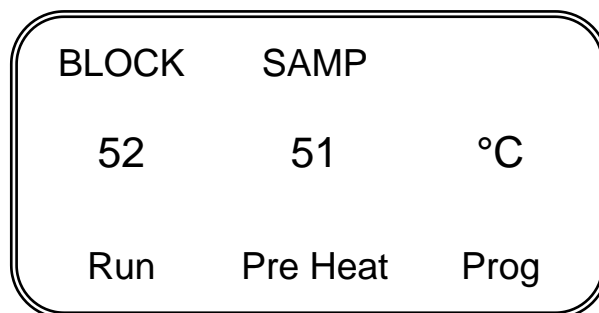

(In all diagrams, the numbers are just examples and will vary)

Press open area above °C or °F symbol to change the degree display to show °C or °F. All parameters that are entered will be remembered in the microprocessor memory and will remain entered until reset.

Program:

To enter a new program while in the opening display press “PROG” and the display will show:

PROG	TEMP	TIME
1	35	62
Back		Run

Press “Back” to return to the opening display, press “Run” to start this program. If the program, temperature or time needs to be changed, press either “PROG,” “TEMP” or “TIME.” The display will show:

PROG	TEMP	TIME
3	67	74
Back	Up	Down
		Run

Ten different programs may be stored and then later recalled. Press “PROG” or “TEMP” or “TIME” and the word will start to flash. Press “Up” or “Down” to change the value. Another word may be selected and the value under the word may be changed by pressing “Up” or “Down.” Press either “Run” to begin the run or press “Back” to return to the opening display.

If “TIME” is set to ON, the program will run continually until turned off by pressing “STOP” or “PAUSE.”

Pre-Heat:

If it is necessary to pre-heat the chamber before starting a run, press Pre-Heat. This display will show:

BLOCK	SAMP	SET TEMP
52	51	85
Stop		

Press “Stop” to return to the opening display and turn off the heater or press “SET TEMP” to set the pre-heat temperature. The display will show:

BLOCK	SAMP	SET TEMP
52	51	90
Stop	Up	Down

The “SET TEMP” will flash. Then press “Up” or “Down” to adjust the block temperature. In this example 52 is the temperature of the sample block, 51 is the upper block or sample temperature. The heater will heat the block and maintain it at the set temperature. Press “Stop” to turn the heater off and to return to the opening display.

Run:

To re-run the last program while in the opening display, press “Run.” The heater will be powered, the master nitrogen control valve will open, the time will start to count down and the display will show:

BLOCK	SAMP	TIME
52	51	124
Pause	Stop	Prog

In this example, 52 indicates the sample block temperature, 51 indicates the upper block temperature or sample temperature, and 124 indicates the time remaining for this programmed run.

Press “Pause” to temporarily halt the run.

BLOCK	SAMP	TIME
57	55	67
Re-Start	Stop	Prog

The word “Pause” will be replaced with “Re-Start” which when pressed will continue the run from the point where it was paused.

Press “Stop” to halt the run entirely. The display will show the opening screen.

If “PROG” is pressed in the middle of a run, the display will show the programmed parameters for that run.

PROG	TEMP	TIME
3	84	103
Back		

Parameters may not be altered. Press “Back” to return to the operating screen. Then if the run parameters must be altered, press “Stop” and re-program the display as described below:

Operating the RapidVap Vertex Evaporator

1. Turn the power switch ON.
2. Turn the nitrogen supply on.
3. Select a program or set the temperature and time parameters. Solvents will evaporate quicker at warmer temperatures. Use care to avoid damaging the samples.
4. Preheat the block if desired.
5. Open a nitrogen control valve for the row of nozzles to be used. Make sure the lid is closed.
6. Set the nitrogen pressure by first selecting the rows of nozzles to be used during the run. Then press run to open the gas supply valve. Pull out the regulator knob and turn the knob until the desired pressure is displayed in the center of the knob. Evaporation rates will be higher at increased pressure. However, splashing of the sample may occur. It is advisable to perform a set up run void of analytes to determine the optimal pressure for the tube and sample size being used. Push the knob in. Turn off the gas supply by pressing Stop or open the lid.
7. Place samples in vials and place vials into the block. If monitoring actual sample temperature, place the temperature probe into sample vial making sure the wires do not cover any nozzles. Close the lid.
8. Press “Run” on the display.
9. At the end of the programmed time the heater and nitrogen flow will turn off. If the display time was set to ON, the run continues until “Stop” or “Pause” is pressed.
10. The lid may be opened and samples removed. Use caution because the block and samples may be hot.

Operational Notes

The LCD display conveys various pieces of information. When the RapidVap Vertex Evaporator is turned ON, the RapidVap Vertex Evaporator will return to the same mode (RUN or STOP) that it was in when the power was turned off. If the RapidVap Vertex Evaporator was in the RUN mode when the power was turned OFF, when the power is turned ON, the RapidVap Vertex Evaporator will attempt to return to the programmed set points.

If the previous run is to be duplicated, it is important to press the “Stop” button prior to pressing “Run.” This will reset the timer back to the programmed set point. Without pressing the program set point button, the time will not be reset and will continue to count down from the time at which it was stopped.

Interrupting a Cycle After it Has Begun

At any time during a run, the cycle may be stopped by pressing the “Pause” button. This shuts off the nitrogen flow and pauses the timer, but the heater remains active. If it is necessary to re-start the RapidVap Vertex Evaporator, close the lid and press “RESTART.” The RapidVap Vertex Evaporator will resume operation at the same set point parameters and the timer will continue to count down from the time at which the RapidVap Vertex Evaporator was paused.

CHAPTER 5

MAINTAINING YOUR

RAPIDVAP VERTEX

EVAPORATOR

Under normal operation, the RapidVap Vertex Evaporator requires little maintenance. The following maintenance schedule is recommended:

As needed:

1. Clean up all spills; remove liquids from chamber.
2. Clean lid and viewing window using soft cloth, sponge or chamois and a mild, non-abrasive soap or detergent.
3. Clean block using non abrasive soap or detergent.

Monthly:

1. The rubber components on the RapidVap Vertex Evaporator may eventually deteriorate and require replacement. The effective life of rubber parts depends upon both their usage and the surrounding environment. Check all rubber hoses and gaskets and replace any that show signs of hardening, permanent set or deterioration.
2. Using a soft cloth, sponge or chamois and a mild, non-abrasive soap or detergent, clean the lid and viewing window.
3. Using a soft cloth, sponge, or chamois and a mild, non-abrasive soap or detergent, clean the exterior surfaces of the unit. Liquid spray cleaners and polishes may be used on the exterior surfaces. Do not use solvents to remove stains from the exterior surfaces as they may damage the finish.
4. Blocks should be cleaned

CHAPTER 6

TROUBLESHOOTING

Refer to the following if your RapidVap Vertex Evaporator fails to operate properly. If the suggested corrective actions do not solve your problem, contact Labconco for additional assistance.

PROBLEM	CAUSE	CORRECTIVE ACTION
Unit will not operate	Unit not connected to electrical power	Connect unit to proper electrical receptacle.
	Circuit breaker blown	Correct electrical problem and reset circuit breaker by pressing button.
	Lid open	Close lid.
Sample odor in lab	Vent hose exhausting into lab area	Redirect hose to fume hood.
	Inoperable blower	Replace blower.
Solvent in bottom of chamber	Gas pressure too high	Reduce pressure.
Poor recovery rates	Sample going to dryness	Program time to prevent dryness.
	Sample splashing out of tube	Decrease Nitrogen pressure.
	Heat setting is too high	Decrease heat.

PROBLEM	CAUSE	CORRECTIVE ACTION
Evaporation rate is reduced	Gas supply depleted	Replenish gas supply.
	Heater inoperable	Contact Labconco.
No gas flow	Gas depleted	Install new supply of gas.
	Sample position not activated	Activate position per operating instructions.
	Nozzle clogged	Unplug nozzle with fine wire.
	Valve inoperable	Contact Labconco
Gas flows continuously	Valve inoperable	Contact Labconco
	Control inoperable	Contact Labconco

APPENDIX A

RAPIDVAP VERTEX

EVAPORATOR COMPONENTS

The following pages list components that are available for your RapidVap Vertex Evaporator. The parts shown are the most common replacement parts. If other parts are required, contact Product Service.

RapidVap Vertex Evaporator Components

Item	Quantity	Part No.	Description
1	5	7320400	Manifold
2	1	7323700	Blower
3	1	7353300	Temperature Sensor Lower
4	1	7325100	Over Temperature Cut Out
5	2	1544600	Inlet Fitting
6A	1	7322200	Control Valve 115V
6B	1	7322201	Control Valve 230V
7	1	3823803	Power Supply
8A	1	1289310	Circuit Breaker 10A (115V)
8B	2	1289306	Circuit Breaker 6A (230V)
9	1	1302300	Power Switch
10	1	7321400	Label – Control Panel
11	1	7321900	Pressure Regulator
12	5	7322500	Valve – Toggle
13	1	7323100	PCB
14	1	7323000	LCD
15	1	7355301	Temperature Sensor Upper

Appendix A: RapidVap Vertex Evaporator Components

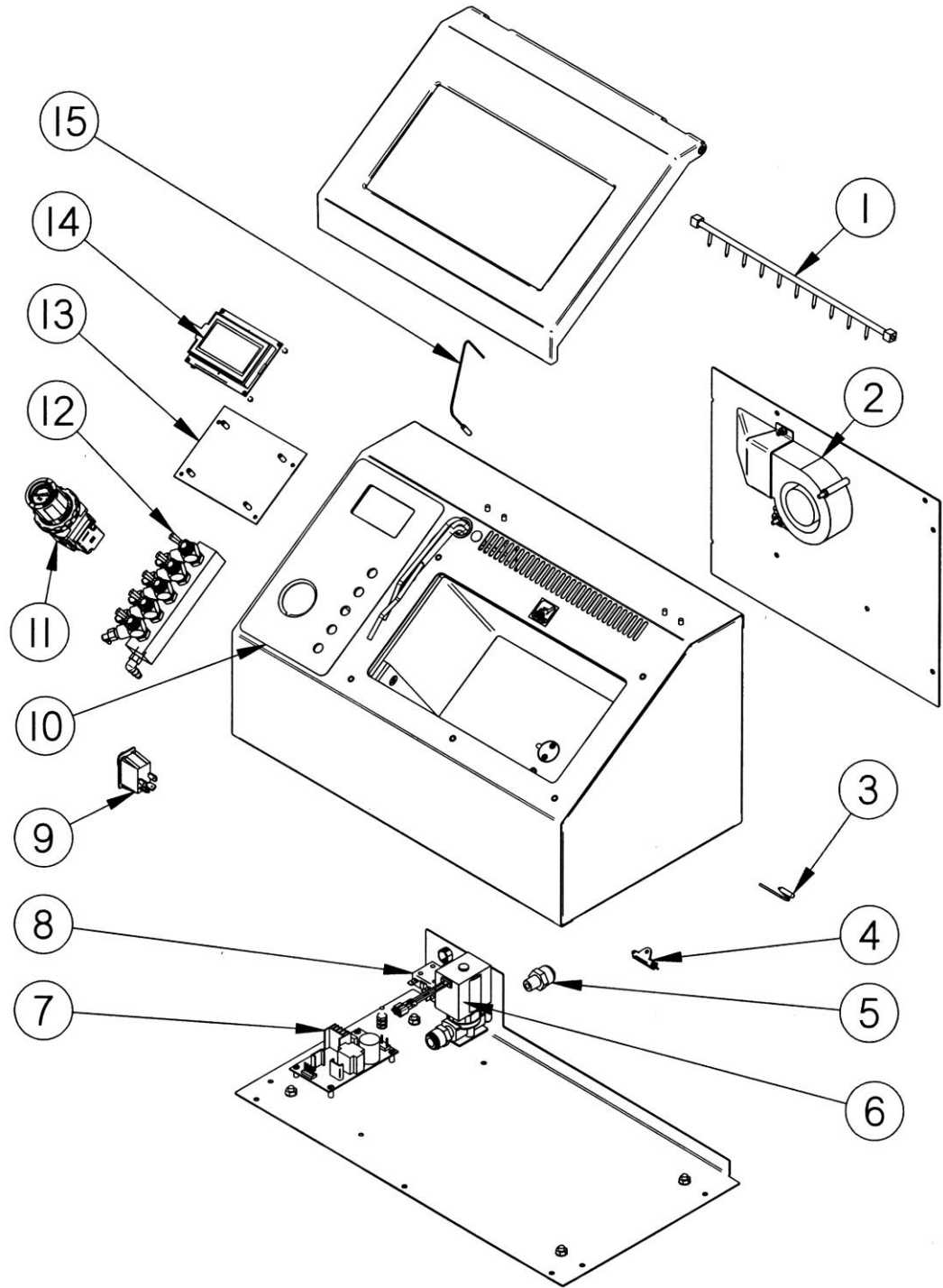

APPENDIX B

RAPIDVAP VERTEX

EVAPORATOR DIMENSIONS

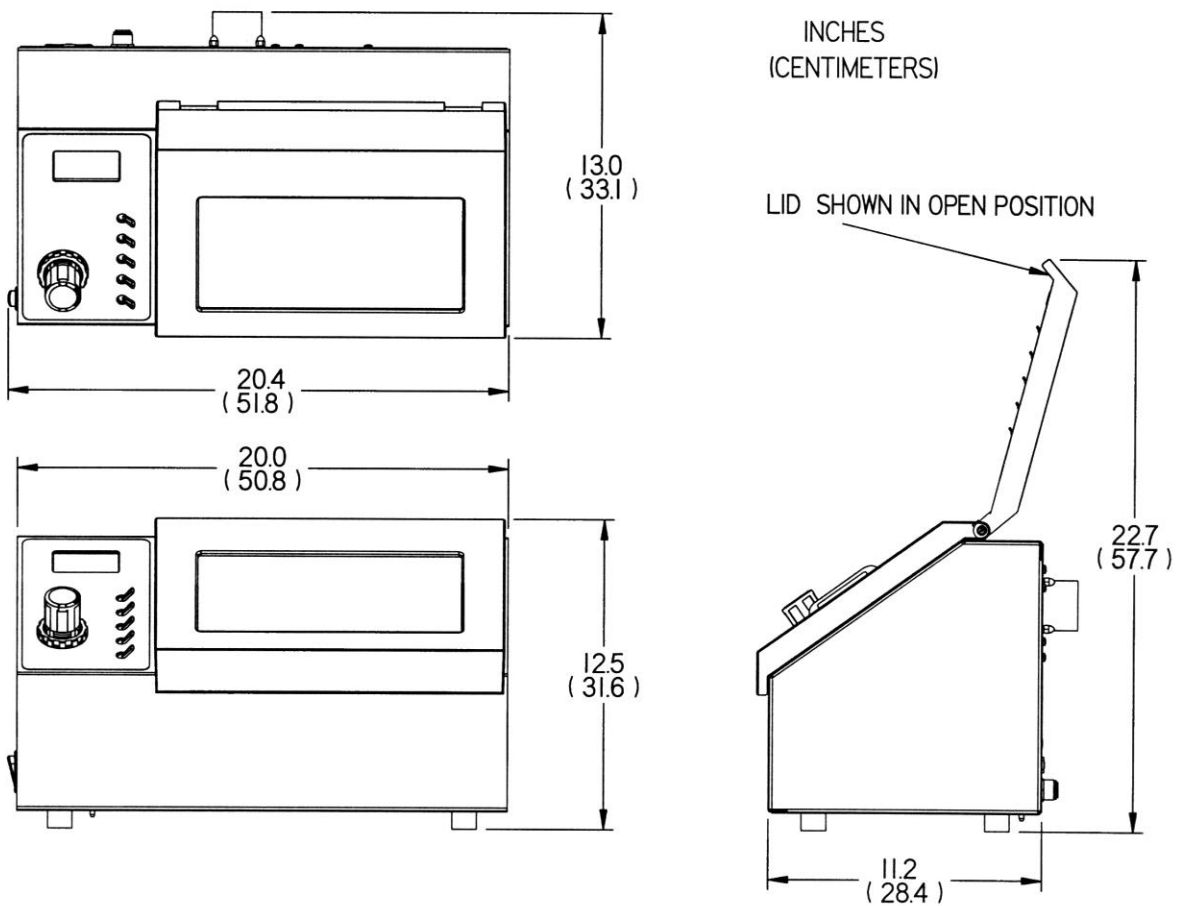

APPENDIX C

RAPIDVAP VERTEX

EVAPORATOR

SPECIFICATIONS

This Appendix contains technical information about the RapidVap Vertex Evaporator including specifications, environmental operations conditions, wiring diagrams and evaporation rates.

Electrical Specifications

- Nominal amperage for 115V RapidVap Vertex Evaporator (model 7320020): 8A
- Nominal amperage for 230V RapidVap Vertex Evaporator Vacuum (models 7320030, 7320035, 7320037, 7320040): 4A
- Frequency (all models): 50/60 Hz
- Phase: Single
- Heater power: 900 watts

Environmental Conditions

- Indoor use only.
- Maximum altitude: 6562 feet (2000 meters).
- Ambient temperature range: 41° to 104°F (5° to 40°C).
- Maximum relative humidity: 80% for temperatures up to 88°F (31°C), decreasing linearly to 50% relative humidity at 104°F (40°C).
- Main supply voltage fluctuations not to exceed $\pm 10\%$ of the nominal voltage.
- Transient overvoltages according to Installation Categories II (Overvoltage Categories per IEC 1010). Temporary voltage spikes on the AC input line that may be as high as 1500V for 115V models and 2500V for 230V models are allowed.

- Used in an environment of Pollution degrees 2 (i.e., where normally only non-conductive atmospheres are present). Occasionally, however, a temporary conductivity caused by condensation must be expected, in accordance with IEC 664.

Nitrogen Consumption

- Gas flow RapidVap Vertex Evaporator with 10 active nozzles:
 - 0.74 SCFM @ 15 psi (21 L/min @ 103 KPA)
 - 1.00 SCFM @ 24 psi (28.3 L/min @ 165 KPA)
- Gas flow RapidVap Vertex Evaporator with 50 active nozzles:
 - 4.5 SCFM @ 20 psi (127 L/min @ 138 KPA)
 - 5.00 SCFM @ 24 psi (141.5 L/min @ 165 KPA)

Evaporation Rates

Solvent	Tube Size (mm)	Number of Samples	Sample Size (ml)	Temp (C)	N ₂ Pressure PSI	*Avg. Time to Dry (min.)
Acetonitrile	12 x 75	10	2	35	16	< 19
	12 x 75	10	2	45	16	<15
	12 x 75	10	2	60	16	<11
	12 x 75	10	2	80	16	<8
Methanol	12 x 75	10	2	35	24	<12
	12 x 75	10	2	45	24	<10
	12 x 75	10	2	60	24	<7
	12 x 75	10	2	80	24	<6
	12 x 75	50	2	80	24	<6
	20 x 150	10	10	52	37	<42
Water	12 x 75	10	2	45	24	<125
	12 x 75	10	2	60	24	<80
	12 x 75	10	2	80	24	<40
	12 x 75	10	2	100	24	<25
	20 X 150	10	4	100	24	<60
	20 X 150	50	4	100	24	<64
Toluene	12 x 75	10	2	35	16	<24
	12 x 75	10	2	45	16	<18
	12 x 75	10	2	60	16	<13
	12 x 75	10	2	80	16	<9
Methylene Chloride	12 x 75	10	2	35	20	<8
	12 x 75	10	2	45	22	<7
	20 x 150	10	10	38	37	<22
Hexane	20 x 150	10	10	52	37	<11
Ethyl Acetate	20 x 150	10	10	52	37	<22

*Time to Dry is the time for samples in each of the indicated number of sample tubes to evaporate. The time to dry for any individual sample tube may be considerably longer or shorter.

APPENDIX D

RAPIDVAP VERTEX

EVAPORATOR ACCESSORIES

PART #	DESCRIPTION
7324100	Block. 10 mm dia. x 75 mm long tubes. Holds 50.
7321200	Block. 12 mm dia. x 75 mm long tubes. Holds 50.
7321300	Block. 13 mm dia. x 100 mm long tubes. Holds 50.
7321600	Block. 16 mm dia. x 125 mm long tubes. Holds 50.
7322000	Block. 20 mm dia. x 150 mm long tubes. Holds 50.
7322800	Block. 28 mm dia. x 95 mm long tubes. Holds 18.
7322801	Block. 28 mm dia. x 140 mm long tubes. Holds 18.
7322300	Block. 17 mm dia. x 125 mm long tubes. Holds 50.
7321601	Block. 16 mm dia. x 100 mm long tubes. Holds 50.