



LABCONCO CORPORATION

8811 Prospect Avenue
Kansas City, MO 64132
(800) 821-5525, (816) 333-8811
(816) 363-0130 fax
labconco@labconco.com

User's Manual

SteamScrubber[®] & FlaskScrubber[®] Glassware Washers

Models

44003 Series
44004 Series
44203 Series
44204 Series
45780 Series
45781 Series

To receive important product updates,
complete your product registration card
online at register.labconco.com

Please read the User's Manual before operating the equipment.

Copyright © 2019 Labconco Corporation. The information contained in this manual and the accompanying products are copyrighted and all rights reserved by Labconco Corporation. Labconco Corporation reserves the right to make periodic design changes without obligation to notify any person or entity of such change.

Warranty

Labconco Corporation provides a warranty to the original buyer for the repair or replacement of parts and reasonable labor as a result of normal and proper use of the equipment with compatible chemicals. Broken glassware and maintenance items, such as filters, gaskets, light bulbs, finishes and lubrication are not warranted. Excluded from warranty are products with improper installation, erratic electrical or utility supply, unauthorized repair and products used with incompatible chemicals.

SteamScrubber® & FlaskScrubber® Glassware Washers carry a two-year warranty from date of installation or three years from date of shipment from Labconco, whichever is sooner. Warranty is non-transferable and only applies to the owner (organization) of record.

Buyer is exclusively responsible for the set-up, installation, verification, decontamination or calibration of equipment. This limited warranty covers parts and labor, but not transportation and insurance charges. If the failure is determined to be covered under this warranty, the dealer or Labconco Corporation will authorize repair or replacement of all defective parts to restore the unit to operation. Repairs may be completed by 3rd party service agents approved by Labconco Corporation. Labconco Corporation reserves the rights to limit this warranty based on a service agent's travel, working hours, the site's entry restrictions and unobstructed access to serviceable components of the product.

Under no circumstances shall Labconco Corporation be liable for indirect, consequential, or special damages of any kind. This warranty is exclusive and in lieu of all other warranties whether oral, or implied.

Returned or Damaged Goods

Do not return goods without the prior authorization from Labconco. Unauthorized returns will not be accepted. If your shipment was damaged in transit, you must file a claim directly with the freight carrier. Labconco Corporation and its dealers are not responsible for shipping damages.

The United States Interstate Commerce Commission rules require that claims be filed with the delivery carrier within fifteen (15) days of delivery.

Limitation of Liability

The disposal and/or emission of substances used in connection with this equipment may be governed by various federal, state, or local regulations. All users of this equipment are required to become familiar with any regulations that apply in the user's area concerning the dumping of waste materials in or upon water, land, or air and to comply with such regulations. Labconco Corporation is held harmless with respect to user's compliance with such regulations.

Contacting Labconco Corporation

If you have questions that are not addressed in this manual, or if you need technical assistance, contact Labconco's Customer Service Department or Labconco's Product Service Department at 1-800-821-5525 or 1-816-333-8811, between the hours of 7:30 a.m. and 5:30 p.m., Central Standard Time.

TABLE OF CONTENTS

CHAPTER 1: INTRODUCTION	1
Safety Symbols	1
CHAPTER 2: PREREQUISITES	3
Hot Water Requirements	3
Purified Water Requirements	3
Electrical Requirements	4
Drain Requirements	5
Space Requirements	5
Safety Precautions	5
CHAPTER 3: GETTING STARTED	7
Unpacking Your Glassware Washer	8
Washer Components	8
Removing the Shipping Skid	10
Washer Installation	10
Installing the Leveling Feet	10
Leveling the Washer	11
Centering the Washer Door	12
Securing the Washer to the Countertop	12
Connecting the Water Services	13
Connecting the Hot Water Supply	13
Connecting the Purified Water Supply	14
Connecting the Drain Hose	16
Connecting the Power Supply	18
Controller Set Up	19
Testing Your Washer	20
Running the Diagnostics	21
CHAPTER 4: USING YOUR WASHER	23
Arranging the Washer Racks	23
The SteamScrubber Racks	23
Removing the Upper Rack	24
The FlaskScrubber Spindle Rack	24
Loading Glassware into the FlaskScrubber	25
The Detergent Dispenser	26

Filling the Neutralizing Acid Dispenser	27
Selecting an Operating Cycle	28
Programming and Starting a Wash Cycle	28
Program Lock	30
Interrupting a Wash Cycle	31
Alarms	31
CHAPTER 5: MAINTAINING YOUR WASHER	33
Maintaining the Stainless Steel Interior	33
Maintaining the Air Gap in Drain	34
Maintaining the Water Fill Valve	34
Removing the Washer Top, Back, and Side Panels	35
Cleaning the Sump Filter Screen	36
CHAPTER 6: MODIFYING YOUR WASHER	37
Adjusting the Height of the Upper Rack	37
Spindle Rack Options	38
Installing Optional Pipet Inserts in a FlaskScrubber	38
Installing the Optional Upper Spindle Rack	40
Installing Optional Inserts into the Spindle Rack	41
Installing Small Spindles	42
Installing the Optional Cool Drain Water Kit	42
Installing the Optional Liquid Detergent Dispenser	43
CHAPTER 7: TROUBLESHOOTING	45
APPENDIX A: GLASSWARE WASHER ACCESSORIES	51
FlaskScrubber Accessories	51
FlaskScrubber or SteamScrubber Accessories	53
Consumables	58
APPENDIX B: GLASSWARE WASHER DIMENSIONS	59
APPENDIX C: GLASSWARE WASHER SPECIFICATIONS	61

CHAPTER 1

INTRODUCTION

Congratulations on your purchase of a Labconco Glassware Washer. Labconco manufactures two types of Glassware Washers, the SteamScrubber® and the FlaskScrubber®. Each of these washers is available in an Undercounter, an Undercounter 33 or a Freestanding model. An optional kit is available to convert Freestanding models to Mobile models. Each washer model is available in 115V or 230V, and with or without a window in the door.

Your Labconco Glassware Washer is designed and manufactured to thoroughly clean your laboratory glassware and accessories and complies with NSF/ANSI 3 standards for sanitization. You can select pre-programmed wash cycles or program customized wash cycles to meet your requirements.

The Glassware Washer graphic display provides operational information. Models with a window and light in the door allow you to visually monitor the operation of your washer. Wash cycles may be programmed to provide steam and the use of purified water in the rinse cycles, allowing you to choose the best conditions for cleaning your glassware.

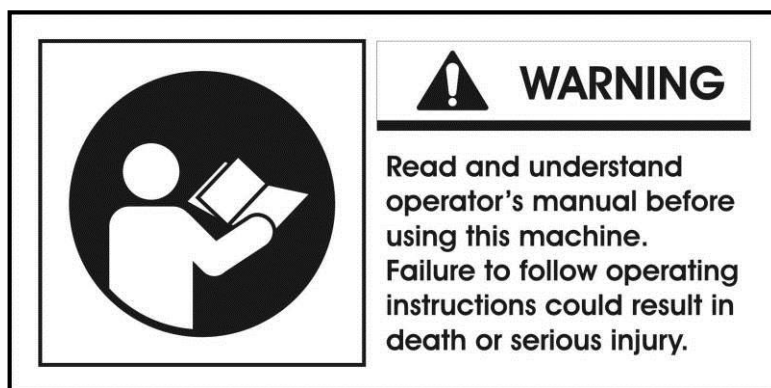

Safety Symbols

Your Glassware Washer was designed with safety in mind, however conditions may exist that could be hazardous.



Throughout this manual potentially hazardous conditions are identified using the following words and symbols.

	<p>This is the safety alert symbol. It is used to alert you to potential personal injury hazards. Obey all safety messages that follow this symbol to avoid possible injury or death.</p>
---	---

 DANGER	<p>DANGER indicates an imminently hazardous situation which, if not avoided, will result in death or serious injury.</p>
 WARNING	<p>WARNING indicates a potentially hazardous situation which, if not avoided, could result in death or serious injury.</p>
 CAUTION	<p>CAUTION indicates a potentially hazardous situation which, if not avoided, may result in minor or moderate injury.</p>
CAUTION	<p>CAUTION used without the safety alert symbol indicates a potentially hazardous situation which, if not avoided, may result in property damage.</p>

It is important that you understand the warnings listed throughout this manual before you operate the Glassware Washer.

CHAPTER 2

PREREQUISITES

Before you install the Glassware Washer, prepare your site for installation. Carefully examine the location where you intend to install the Glassware Washer. You must be certain that the area is level and of solid construction. In addition, a hot water source, a drain, a purified water source (if applicable), and an electrical source must be located near the installation site. A cold water source is required when the optional Cool Drain Water Kit is installed.

Refer to *Appendix C: Glassware Washer Specifications* for complete Glassware Washer electrical and environmental conditions, specifications and requirements.

Hot Water Requirements

An existing hot water supply may be used as the hot water source for your Glassware Washer. Labconco recommends the inlet water temperature to be greater than 120°F (49°C) to fully activate powdered detergents and raise the glassware temperature to achieve fast and complete drying. Hotter water will produce better washing results.

Water pressure must be between 20-120 psi (138-827 kPa) at the washer and provide a minimum of 1.25 gallons (4.7 liters) per minute flow rate.

A shut-off valve should be installed in the water supply line plumbed to the washer. The hot water inlet valve on the Glassware Washer is equipped with a female 3/8 NPT fitting. A compression fitting is provided that connects to .375" (9.53mm) OD copper tubing.

Purified Water Requirements

To use purified water for the rinse cycles, a purified water supply is required. The washer can be connected to an in-house, pressurized, purified water tap; a water purification system; or a non-pressurized purified water container.

The purified water system must be provided with supply piping of sufficient size to permit at least 0.9 gallons (3.4 liters) per minute of flow. Tubing with an internal diameter of at least .375" (9.53 mm) is recommended. The purified water inlet valve on the washer is equipped with a plastic hose barb connection to accommodate .375" (9.53 mm) ID flexible plastic or rubber hose. Use a spring or band hose clamp to secure the hose to the hose barb connection. The hose barb connection may be removed from the valve to expose a male 3/4" - 11-1/2 NH hose coupling. Rigid plastic, tin-lined, or stainless steel tubing and fitting can be connected to the washer fitting.

An optional connection kit (Labconco P/N 4592200) is available for connecting .375" (9.53mm) OD plastic tubing to the purified water inlet valve. The purified water system connections must be airtight to prevent the washer pump from pulling air instead of water.

If the purified water is stored in a carboy, at least 3.4 gallons (13 liters) must be available for each rinse. If all the purified water is not available at the start of a wash cycle, but instead is produced concurrently with the wash cycle, the production rate must permit at least 0.9 gallon (3.4 liters) per minute to be delivered to the washer.

Electrical Requirements

Undercounter and Freestanding models, are hard-wired directly into a junction box using conduit. A 20 Amp circuit breaker or fuse is required for models rated at 115V (60 Hz) or 230V (50/60 Hz).

High voltage models are designed to operate at 230 VAC, single phase. It will operate safely at nominal 208 VAC, however the heater output will be reduced proportionally. As the operating voltage drops below 230V a boost transformer can be used if higher voltage is preferred.

If your Glassware Washer is converted to a Mobile model, a dedicated electrical outlet is required. A 20 Amp circuit breaker or fuse is required for models rated at 115V (60 Hz) or 230V (50/60 Hz). 115V models are equipped with a 20 Amp NEMA 5-20P plug. 230V models are equipped with a 15 Amp NEMA 6-15P plug. It may be necessary to remove the plug and install a different plug to match the available receptacle.

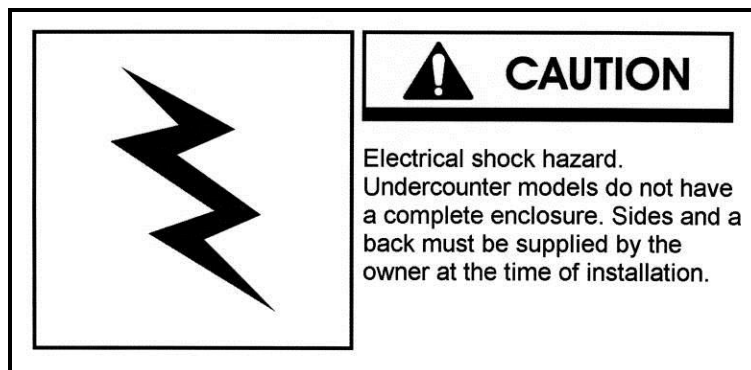

Drain Requirements

The drain hose, .57" (1.45 cm) ID is installed during manufacture. The hose provides a flexible coupling to the building drain piping and can be secured with a spring or band hose clamp. (A band hose clamp is provided with the washer.)

Tubing or pipe, 5/8" (1.6 cm) ID or larger, should be provided for the building drain. The use of an air gap is strongly recommended to prevent siphoning of wastewater into the washer.

Do not reduce the size of the drain plumbing.

Glassware Washers that have been converted to Mobile models drain into a sink through a hose assembly that attaches to the faucet.

Space Requirements

If your Glassware Washer is an Undercounter model, you must ensure the undercounter opening is the proper size to accommodate the washer. The dimensions for the Undercounter washer are shown in Appendix B.

Safety Precautions

When lifting this product, use at least two (2) persons and always use safe lifting practices.

Do **NOT** use a detachable power cord that is not adequately rated for this product.

Always disconnect power before beginning service operations.

Do not damage internal wiring or other components while service panels are removed. If internal wiring or components are damaged, do not restore power, contact Labconco's Product Service Department immediately.

Wear all required Personnel Protective Equipment (PPE) during service operations. At a minimum, this includes: eye protection, breathing protection, skin protection. Do not wear loose fitting clothes that can catch on internal surfaces.

After service, verify safe state of use before using the product. Contact Labconco's Product Service Department for questions on determining safe state of this product.

Verify protective earth ground continuity before using equipment.

No special ventilation requirements.

Chapter 2: Prerequisites

No hazards exist for: explosion, implosion, or release of toxic or flammable gases arising from the materials being heated.



No Heat Transfer Media is required for the normal operation of this equipment.

Cleaning solutions that do not contain chlorine-based disinfectants (such as Bleach or hypochlorites) may be safely used on this equipment.

If there is any doubt about the compatibility of decontamination or cleaning agents, contact Labconco's Product Service Department.

To verify door safety interlock is functioning properly, close the washer door, secure the door latch, and start a program. Once program has begun, open the door by unlatching the door latch. All functionality must stop, and power is removed from the display screen (it goes black). If this result is not achieved, do not use the product and contact Labconco's Product Service Department immediately.

	CAUTION HOT! Steam and surfaces within this washer and its contents may become hot enough to cause burns. Do not place any flammable liquids in this washer. Failure to empty and rinse glassware could result in fire or explosion.	
---	--	---

	ATTENTION CHAUD! La vapeur et les surfaces à l'intérieur de cette laveuse et son contenu peuvent devenir suffisamment chauds pour causer des brûlures. Ne placez aucun liquide inflammable dans cette laveuse. Il y a risque d'incendie ou d'explosion si la verrerie n'est pas vidée ni rincée.	
---	--	---

CHAPTER 3

GETTING STARTED

Now that the site for your Glassware Washer is properly prepared, you are ready to unpack, inspect, install, and test your washer.

You may need common plumbing and electrical installation tools in addition to a 9/16" wrench, a flat-blade screwdriver, a Phillips screwdriver, and a carpenter level to complete the instructions in this chapter.



The Glassware Washer weighs over 150 lbs. (68 Kg). The carton allows for lifting with a mechanical lift truck or hand truck. If you must lift the washer manually, use at least two (2) persons and follow safe lifting guidelines.

	 CAUTION Lifting hazard. Do not lift or move this equipment without assistance.
---	---

Unpacking Your Glassware Washer

Carefully unpack your Glassware Washer and inspect it for damage that may have occurred in transit. If your Glassware Washer is damaged, notify the delivery carrier immediately and retain the entire shipment intact for inspection by the carrier.

The United States Interstate Commerce Commission rules require that claims be filed with the delivery carrier within fifteen (15) days of delivery.

Do not discard the carton or packing material for your Glassware Washer until you have checked all of the components and installed and tested the Glassware Washer.

NOTE: Do not return goods without the prior authorization of Labconco. Unauthorized returns will not be accepted. If your Glassware Washer was damaged in transit, you must file a claim directly with the freight carrier. Labconco Corporation and its dealers are not responsible for shipping damage.

Do not remove the washer from its shipping skid until it is ready to be placed into its final location. Move the washer by placing a flat, low dolly under the shipping skid.

Washer Components

Locate the model of washer you received in the following group of tables. Verify that the components listed are present and undamaged.

Catalog #	Washer Description	SteamScrubber Undercounter Models
4400320	SteamScrubber Undercounter – 115 V with upper & lower racks	
4400321	SteamScrubber Undercounter – 230 V with upper & lower racks	
4400330	SteamScrubber Undercounter – 115 V with window, upper & lower racks	
4400331	SteamScrubber Undercounter – 230 V with window, upper & lower racks	
4578020	SteamScrubber 33 Undercounter – 115 V with upper & lower racks	
4578021	SteamScrubber 33 Undercounter – 230 V with upper & lower racks	
4578030	SteamScrubber 33 Undercounter – 115 V with window, upper & lower racks	
4578031	SteamScrubber 33 Undercounter – 230 V with window, upper & lower racks	
Plus the Following Loose Parts:		
Part #	Component Description	
1879801	Leveling Feet (4)	
4591100	User Manual	
4462900	Screws (2)	
1488800	Clamp (1)	
4522500	LabSolutions Powder Detergent with MSDS – 6 ounces (175 grams)	
1410700	Water Connector	
1448700	Coupling & Sleeve (1)	
Catalog #	Washer Description	SteamScrubber Freestanding Models
4400420	SteamScrubber Freestanding – 115 V with upper & lower racks	
4400421	SteamScrubber Freestanding – 230 V with upper & lower racks	
4400430	SteamScrubber Freestanding – 115 V with window, upper & lower racks	
4400431	SteamScrubber Freestanding – 230 V with window, upper & lower racks	

Plus the Following Loose Parts:

Part #	Component Description
1879801	Leveling Feet (4)
4591100	User Manual
4468000	Hole Plug (2)
1488800	Clamp (1)
4522500	LabSolutions Powder Detergent with MSDS – 6 ounces (175 grams)
1410700	Water Connector (1)
1448700	Coupling & Sleeve (1)

Catalog #

Washer Description

4420320	FlaskScrubber Undercounter – 115 V with lower spindle rack
4420321	FlaskScrubber Undercounter – 230 V with lower spindle rack
4420330	FlaskScrubber Undercounter – 115 V with window with lower spindle rack
4420331	FlaskScrubber Undercounter – 230 V with window with lower spindle rack
4578120	FlaskScrubber 33 Undercounter – 115 V with lower spindle rack
4578121	FlaskScrubber 33 Undercounter – 230 V with lower spindle rack
4578130	FlaskScrubber 33 Undercounter – 115 V with window & lower spindle rack
4578131	FlaskScrubber 33 Undercounter – 230 V with window & lower spindle rack

**FlaskScrubber
Undercounter
Models**

Plus the Following Loose Parts:

Part #	Component Description
4584600	Lower Spindle Rack with 36 spindles
1879801	Leveling Feet (4)
4591100	User Manual
4462900	Screws (2)
1488800	Clamp (1)
4522500	LabSolutions Powder Detergent with MSDS – 6 ounces (175 grams)
1410700	Water Connector (1)
1448700	Coupling & Sleeve (1)
4525200	Spindle – Small (10)
4414703	Clip – Spindle (10)
4425101	Plug – Spindle (36)

Catalog #

Washer Description

4420420	FlaskScrubber Freestanding – 115 V with lower spindle rack
4420421	FlaskScrubber Freestanding – 230 V with lower spindle rack
4420430	FlaskScrubber Freestanding – 115 V with window with lower spindle rack
4420431	FlaskScrubber Freestanding – 230 V with window with lower spindle rack

**FlaskScrubber
Freestanding
Models**

Plus the Following Loose Parts:

Part #	Component Description
4584600	Lower Spindle Rack with 36 spindles
1879801	Leveling Feet (4)
4591100	User Manual
4468000	Hole Plug (2)
1488800	Clamp (1)
4522500	LabSolutions Powder Detergent with MSDS – 6 ounces (175 grams)
1410700	Water Connector (1)
1448700	Coupling & Sleeve (1)
4525200	Spindle – Small (10)
4414703	Clip – Spindle (10)
4425101	Plug – Spindle (36)

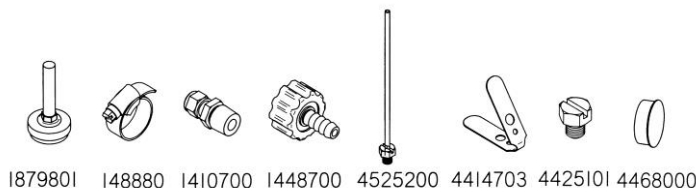

If you did not receive one or more of the components listed for your washer, or if any of the components are damaged, contact Labconco Corporation immediately for further instructions.

Removing the Shipping Skid

After you verify the washer components, move your washer to the location where you want to install it. Then, follow the steps listed below to remove the shipping skid from your washer.

To remove the shipping skid:

1. Remove accessories and loose items from inside the washer. Cut tie wraps and remove racks.
2. Gently place the washer on its back, positioning the washer on the shipping carton or other cushioning material.
3. Remove the four screws fastening the skid to the washer.
4. Retain the shipping skid until you test the various features of the washer.

Washer Installation

After you remove the skid from your washer, you must install leveling feet on the bottom of the washer. If you have an Undercounter or Freestanding model, then you must level the washer and center the washer door. If you have an Undercounter model, you must also secure the washer to the underside of the countertop or worksurface.

Installing the Leveling Feet

1. Locate the holes on the bottom of the washer where the four skid-fastening screws were previously attached.
2. Thread the four leveling feet into the holes.
3. Carefully move the washer into an upright position. Be careful to distribute the weight evenly on the leveling feet when setting the washer upright.
4. Reinstall racks.

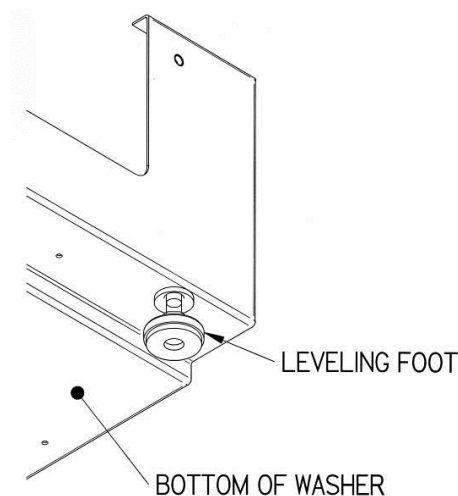

Leveling the Washer

If you have a Freestanding model of the SteamScrubber or FlaskScrubber Glassware Washer, after you have installed the leveling feet, level the washer by adjusting the leveling feet.

1. Position the washer in its final installed location.
2. Place a carpenter level on the washer in the positions shown.

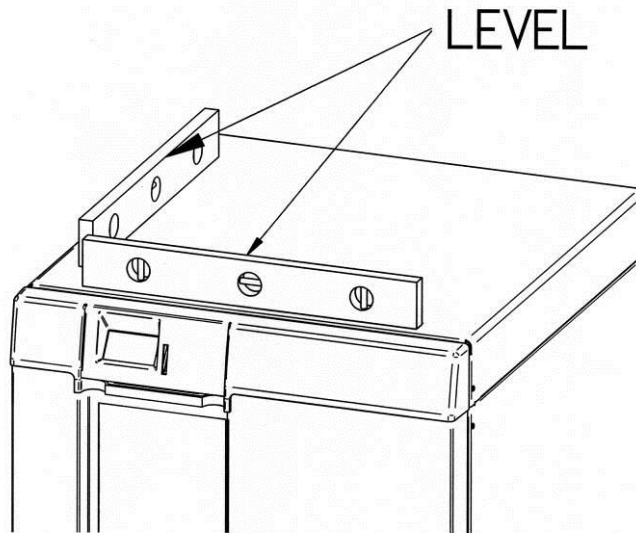

3. Turn the four leveling feet, as needed, to level the washer.

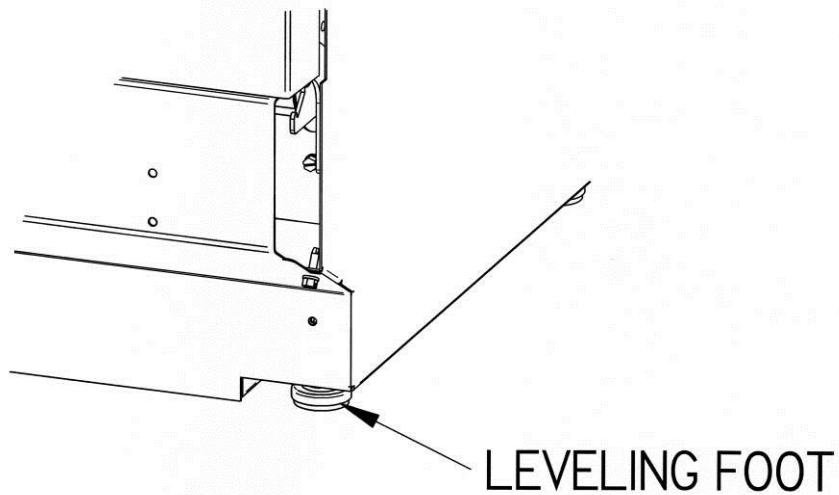

If you have an Undercounter model, level it side-to-side by placing a short level on the inside top edge of the door. See the figure below for the placement of the level on the washer. Check the level front to back by placing a level on the rail that the lower rack slides on.

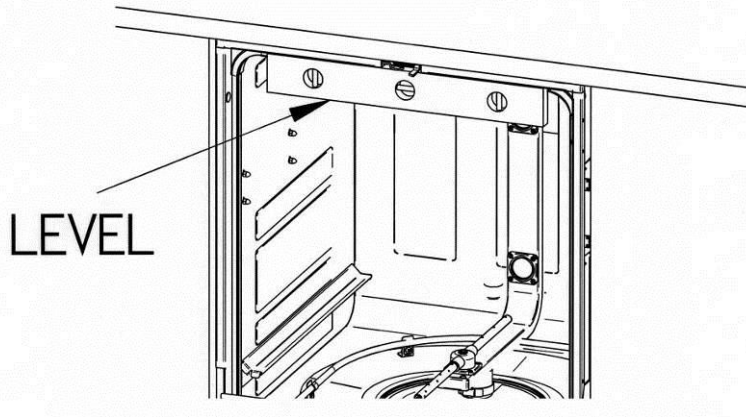

Centering the Washer Door

When the washer is level, check the operation of the washer door for alignment with the washer tank. If the door is not centered in the opening, you must center the door by adjusting the corresponding leveling foot. (For example, if the door hits the right side of the tank, raise the right front corner of the washer. If the door hits the left side of the tank, raise the left front corner of the washer.)

Securing the Washer to the Countertop

If you have an Undercounter Glassware Washer, two screws have been provided to attach the front of the washer to the underside of the countertop or work surface. After the washer is leveled in its final position and the washer door is properly centered, install the two screws as shown in the figure below to stabilize the unit and prevent it from moving.

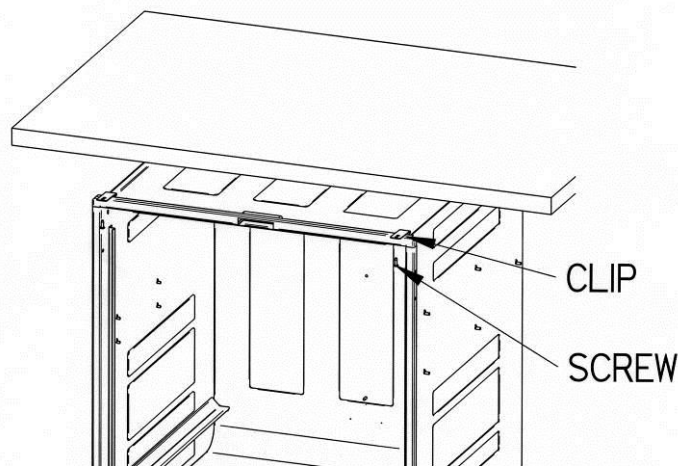

Connecting the Water Services

A hot water supply must be attached to your Glassware Washer. In addition, a purified water source must be connected to your washer if pure water rinses will be required.

Connecting the Hot Water Supply

To prevent valve clogging, thoroughly flush the hot water lines for your hot water supply source prior to connecting the washer to the water lines. The water supply valve to which the hot water supply is connected is located on the back of the washer base. The back panel of FreeStanding models must be removed to access the valve.

You must provide the plumbing fittings and components needed to connect the hot water supply source. The washer hot water supply valve is equipped with a compression fitting for a .375" (9.53 mm) OD tube.

To connect the hot water supply:

1. Be certain the hot water supply piping has been thoroughly flushed prior to connecting it to the washer. Debris in the piping can clog the washer valve.
2. Make the necessary plumbing connections to properly connect the hot water supply to the washer.
3. It may be necessary to place a loop in the supply tube to allow the washer to be slid in or out of its operating position. Be careful not to kink the water supply tube when the washer is placed into its final location. If kinking occurs, it may be necessary to replace the straight fitting on the valve with an elbow.

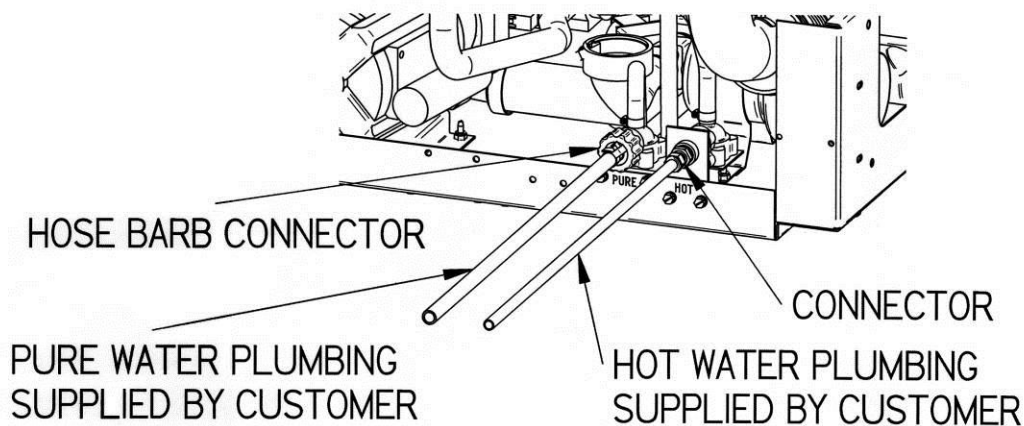

Washer Back View

Connecting the Purified Water Supply

To prevent valve and pump clogging, flush all of the water lines for your purified water supply source prior to connecting the washer to the water lines. The valve to which the purified water supply must be connected is located on the back of the washer base. The back panel of Freestanding models must be removed to access the valve. Refer to the previous figure.

The purified water inlet valve is equipped with a plastic hose barb connection to accommodate .375" (9.53 mm) ID flexible plastic or rubber hose. The hose connection may be removed from the valve to expose a male 3/4" – 1 1/2 NH hose coupling. Rigid plastic, tin-lined, or stainless steel tubing and fittings may be connected to the washer fitting.

At least 0.9 gallon (3.4 liters) per minute of purified water flow is required. At least 3.4 gallons (12.9 liters) of purified water must be available for each pure rinse. A .375" (9.5 mm) ID pipe is the minimum recommended.

If you do not use purified water during the rinse cycles, you may disable the purified water pump. Refer to Controller Set-Up in this section.

If the washer has been converted to a Mobile model and is moved to various locations, and if purified water is used, provisions must be made to use a flexible hose from a source of house-purified water. If a carboy is used, place the carboy on a carboy cart and move it with the washer. Be careful not to let the hose kink or become damaged.

To connect the purified water supply:

1. Make certain the purified water supply piping has been thoroughly flushed prior to connecting it to the washer.
2. Make the necessary plumbing connections to properly connect the purified water supply to the washer.

NOTE: If the purified water source is a carboy, complete steps 3 and 4.

3. Connect the purified water source through either the top or the bottom of the carboy, as illustrated in the following figures. If the purified water supply feeds directly from the carboy top, make certain the hose is submerged under the water line. Attach a weight to the end of the tubing to keep it from floating on top of the water and possibly allowing air into the system.
4. Make certain the top of the carboy is vented to permit proper flow from the carboy to the washer. Make certain that all of the connections on the purified water system are air tight. The pump must not pull air instead of water. Make certain the supply hose is not crimped.

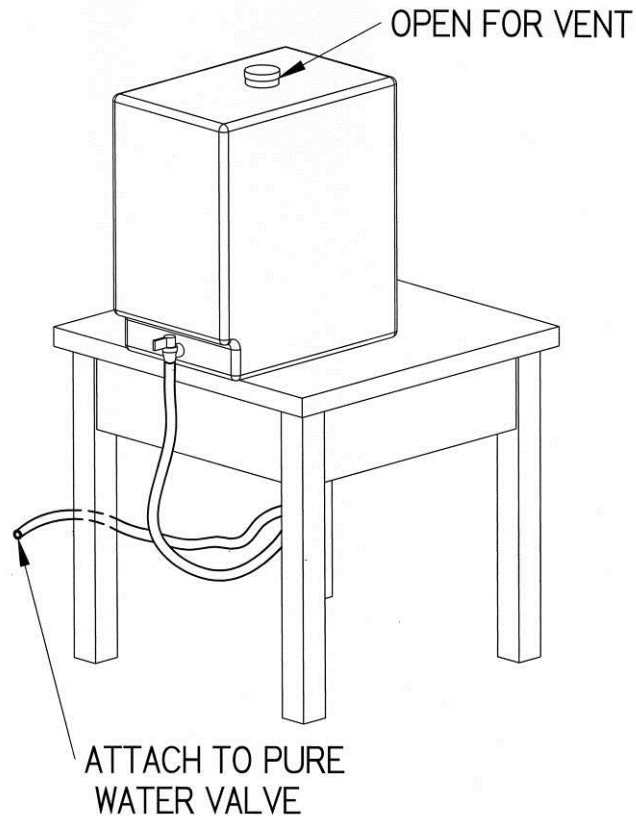

Example of a Bottom Feed Connection

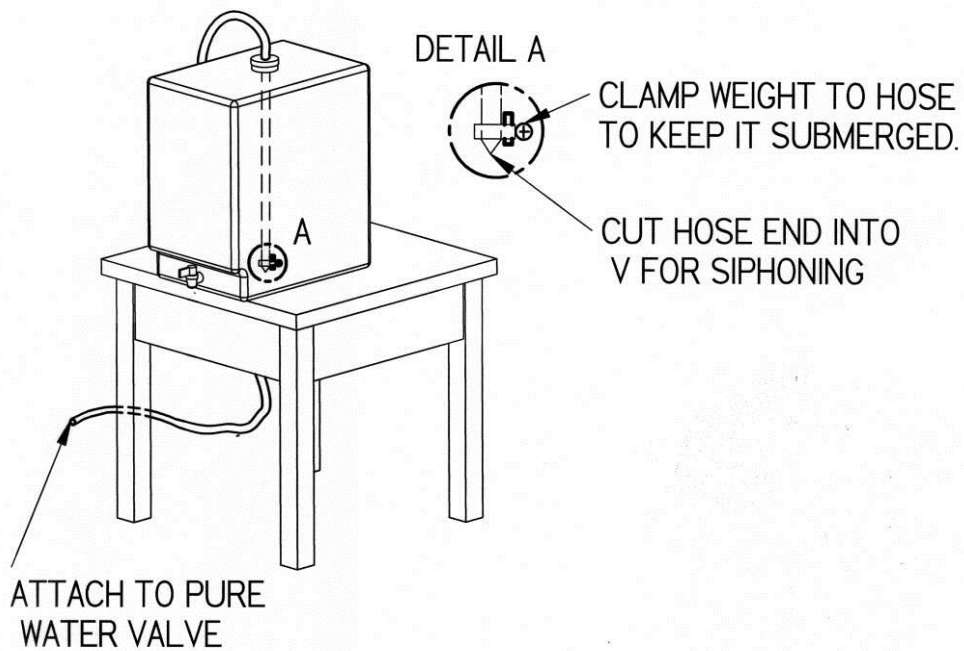

Example of a Top Feed Connection

Connecting the Drain Hose

Before continuing with this section, be certain that your drain meets the requirements detailed in *Drain Requirements* in *Chapter 2: Prerequisites*.

Be certain you conform to all local plumbing codes when you route and connect the drain.

The drain hose is installed at the factory. The hose provides a flexible coupling to the drain piping and can be secured with a spring or band hose clamp. (A band hose clamp is provided with your washer.)

Tubing or pipe 5/8" (1.6 cm) ID or larger should be used for the drain.

Do not route the drain to an elevation more than 36" (91 cm) above the pump discharge. Do not reduce the size of the drain plumbing.

Do not remove the hose from the clamp on the rear of the glassware washer.

The use of an air gap is strongly recommended for all installations to prevent the siphoning of wastewater into the washer.

The drain piping can be routed to either a sink or a floor drain. If you route the drain piping to a sink drain without using an air gap, the highest point of the drain pipe must be above the highest water level in the sink, as shown below.

If an air gap is not used, the drain line must be elevated above the water level of the sink.

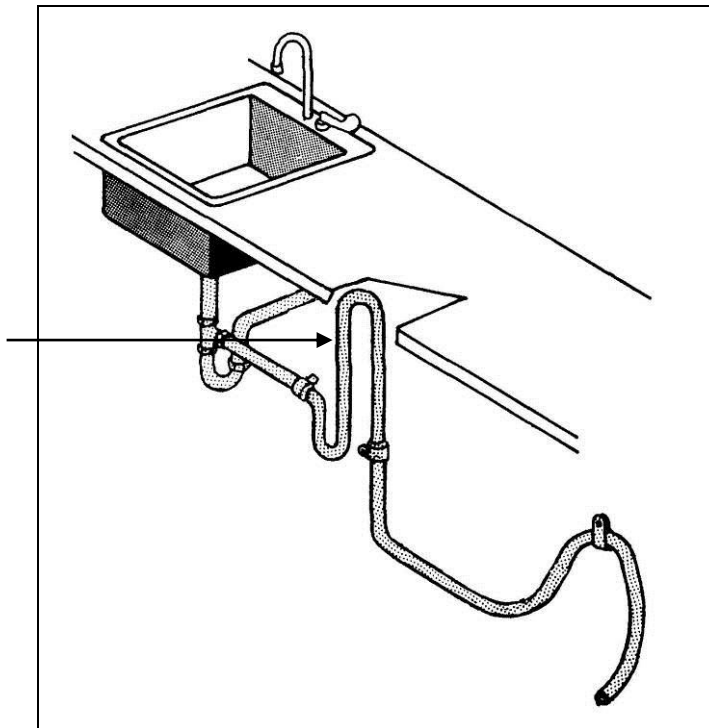

If you route the drain piping to a sink drain and use an air gap, refer to the figure below for the placement of the air gap.

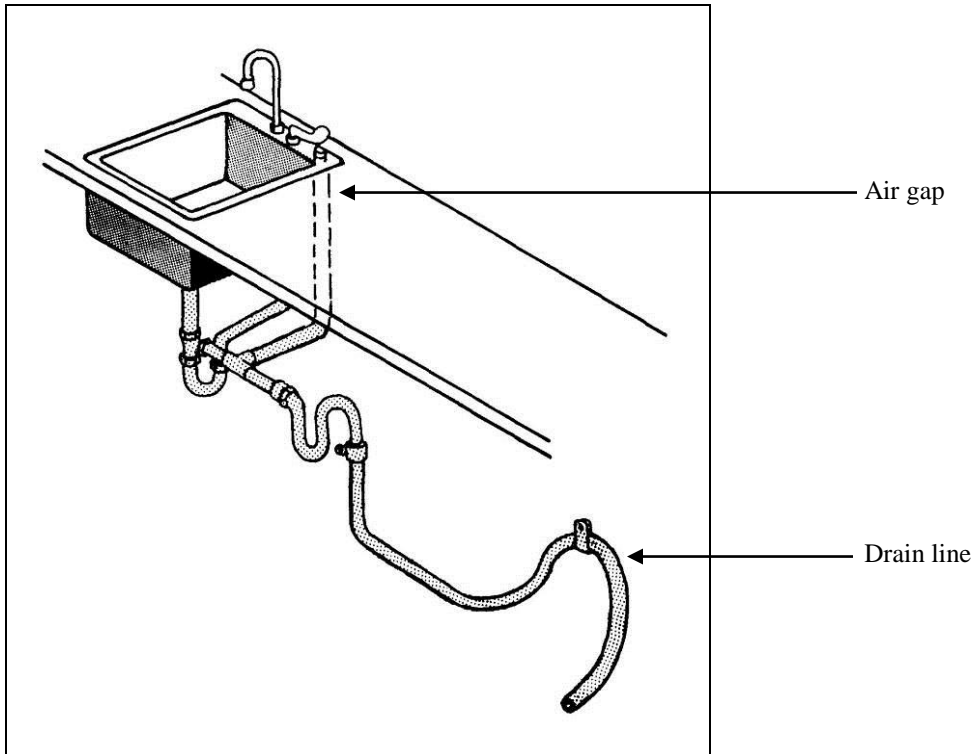

If you route the drain piping to a floor drain, refer to the figure below for placement of the drain tubing and trap.

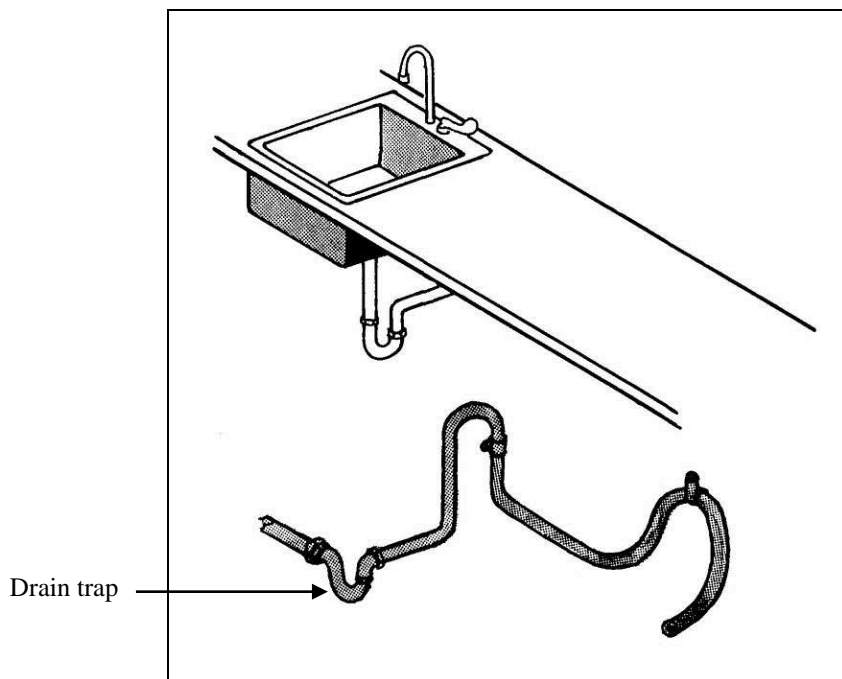

Connecting the Power Supply

Before continuing with this section, be certain your power supply meets the requirements specified on the washer data plate and in *Electrical Requirements* in *Chapter 2: Prerequisites*. Undercounter and Freestanding Washers should be hard-wired directly into a junction box. Refer to the figure below and follow the steps below to connect your washer to the appropriate power source.

Be certain that you check and conform to all local electrical codes. Do not disturb any internal wiring in the washer.

If you are connecting to certain legs of a 3-phase power system to obtain single-phase power, be sure to consult a professional to insure codes/standards are followed. These professionals can determine the appropriate connections for either a Wye or Delta connected power source.

The supply circuit must consist of number 12 AWG 3-wire cable or heavier. Washers must be connected to a dedicated service with a 20 amp circuit breaker or fuse. Wire must comply with all local electrical codes. Type THW or THWN wire may be used if it complies.

To connect the electrical supply:

1. Remove 2 screws on each side of the middle panel.

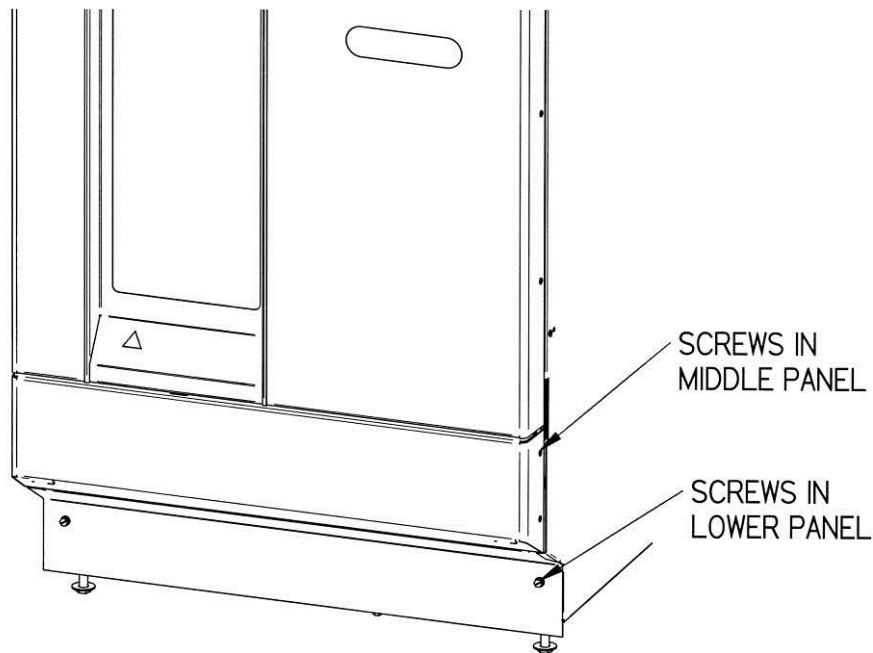

2. Pull the middle panel forward and remove it.
3. Remove the lower panel on the washer front by removing the two screws located at the bottom of the panel.

4. Remove the cover over the electrical junction box by removing the two screws.

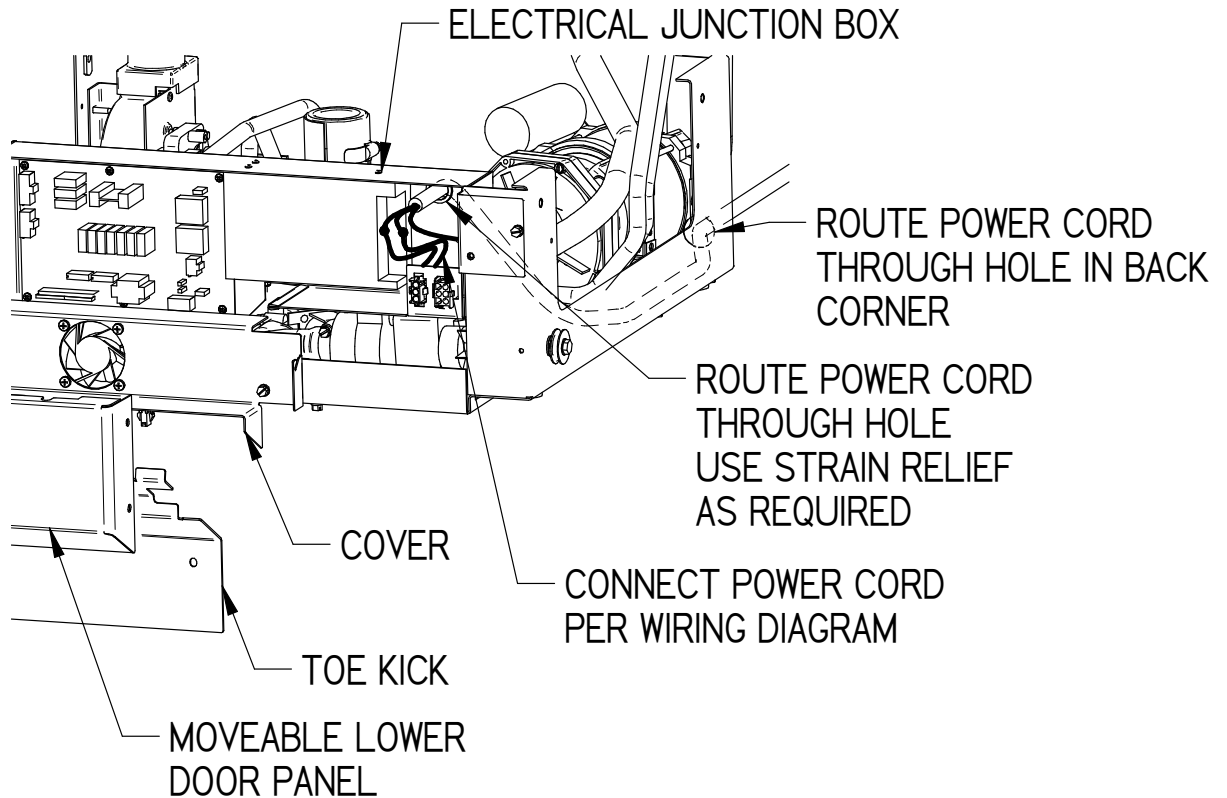

5. Make sure electrical power is turned off before making any connections.
6. On 115V models, connect the customer-supplied power wires to the black and white wires, using wire connectors. On 230V models, attach customer-supplied power wires to the brown and blue wires, using wire connectors. Customer-supplied wires must be clamped to the hole where they pass through the rear of the junction box, if prescribed by local codes. If it is necessary to use a bushing with an integral clamp at the inlet to the junction box, remove the plastic bushing supplied with the washer before installing the new customer supplied bushing.
7. Connect the customer-supplied ground wire to the green screw.
8. Replace the cover on the electrical junction box.
9. Replace the lower panel and door panel assembly on the washer.

Controller Set-Up

The washer control system has been set at the factory to agree with the configuration of the washer as it was shipped. The control may be customized or modified if certain optional accessories are added.

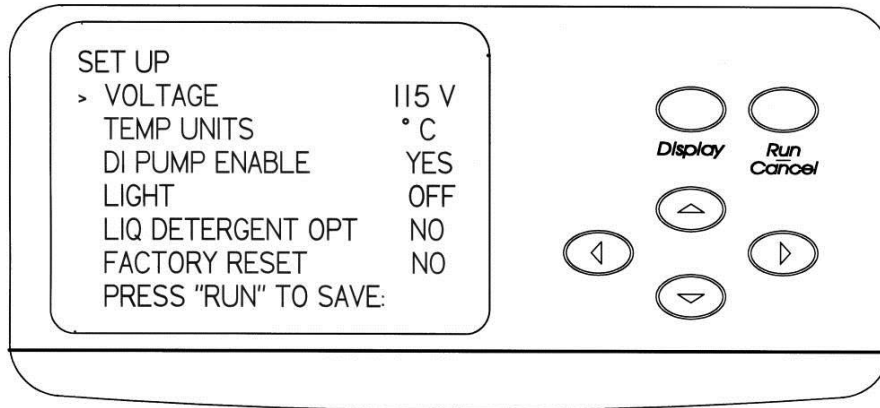

To set up the washer control:

1. Locate the control panel on the front of the washer.
2. Press and hold the ▼ button and close the handle of the washer by sliding the door latch knob to the right. Hold for 5 seconds.
3. The display will show the SET UP screen.
4. The > on the left side will highlight VOLTAGE.
5. Press the ◀ or ▶ buttons to select the correct operating voltage of the washer.
CAUTION: The voltage selected (115V or 230V) does not change the acceptable AC mains voltage that can be connected to the washer. It only selects the programs that are suitable for the identified voltage.
6. Press the ▼ button and TEMP UNITS will highlight.
7. Press ◀ or ▶ buttons to select either °F or °C which will be used on the display to set and monitor temperature.
8. Press the ▼ button and DI PUMP ENABLE will highlight.
9. Press ◀ or ▶ buttons to YES or NO. This allows the pure water valve and pump to be disabled if pure water will not be used for rinse cycles and prevents inadvertently programming a cycle to have pure rinses.
10. Press the ▼ button and LIGHT will be highlighted on the display.
11. Press ◀ or ▶ to cause the light inside the tank on window models to be turned on or off while the door is latched.
12. Press the ▼ button and LIQ DETERGENT OPT will be highlighted on the display.
13. Press ◀ or ▶ to activate the control for the liquid detergent dispense option if this accessory has been installed.
14. Press the ▼ button and FACTORY RESET will be highlighted on the display.
15. Press the ◀ or ▶ to select YES to erase all program set points entered by the user and to restore all set points that were active when the washer was shipped.
16. Press RUN to save all settings.

Testing Your Washer

Now that you have made the required water and electrical connections to your washer, a series of diagnostic steps are provided in this section to test the operation of the washer.

Before turning on the washer, make certain the water is turned on and no packing material remains inside the washer.

If the washer is interrupted in the middle of the diagnostic steps, wait 4 to 5 seconds before opening the washer door to prevent hot water from splashing out. The hot water and steam from the washer may cause scalding.

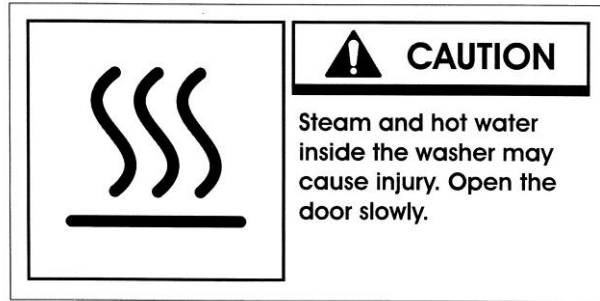

Running the Diagnostics

To ensure your washer is operating properly, perform the diagnostics procedure detailed below, which will take approximately 10 minutes to complete. Refer to the figure below to familiarize yourself with the control panel before you begin the procedure.

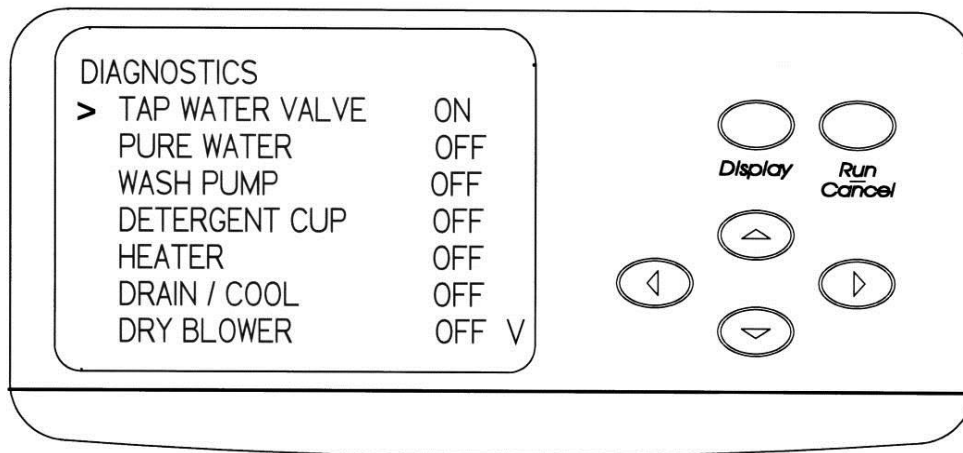

To run the diagnostics test:

1. Press the ▲ button on the control panel and close the door and slide the door latch to the right. Hold for 5 seconds.
2. The display will show the Diagnostics screen and the indicator on the left side will point to TAP WATER VALVE.
3. Press either the ► or ◀ button to turn the tap water valve ON. Tap water should enter the washer. Allow water to enter for approximately 1 minute. Press either the ► or ◀ button to turn the water off.
4. Press the ▼ button and the arrow on the display will point to PURE WATER.
5. Press either the ► or ◀ button turn the pure water pump ON and open the pure water valve. Allow pure water to enter the washer. After about 3 minutes the fill switch should cause the water flow to turn off.
6. Press the ▼ button and the arrow on the display will point to WASH PUMP.
7. Press the ► or ◀ button and the wash pump should energize.

8. Press the ▼ button and the arrow on the display will point to DETERGENT CUP.
9. Press either the ► or ◀ button to energize the detergent cup. Within about 1 minute the detergent cup door should be heard to open.
10. Press the ▼ button and the arrow on the display will point to HEATER.
11. Press either the ► or ◀ button and the heater will be energized.
12. Press the ▼ button and the arrow on the display will point to DRAIN / COOL.
13. Press either the ► or ◀ button and the drain will be energized. Allow all water to be drained from the washer. The sound of the pump will change when all water is drained. This will take about 1-1/2 to 2 minutes. If the Cool Water Drain Kit accessory has been installed, cool water will mix with hot water draining from the washer.
14. Press the ▼ button and the arrow on the display will point to DRY BLOWER.
15. Press either the ► or ◀ button and the dry cycle blower will be energized.
16. The ▼ arrow in the lower right side of the display indicates that more selections may be made. Press the ▼ button to select the next function to test. The arrow on the display will point to LIQ DETERG PUMP.
17. Press the ► or ◀ button and if the liquid detergent accessory has been installed and if it was activated in the Set Up procedure, the detergent pump will operate.
18. Press the ▼ button and the arrow on the display will point to LIGHT.
19. Press either the ► or ◀ button and if the washer is equipped with a window in the door, the light inside the washer will illuminate.
20. Press the ▼ button and the arrow on the display will point to COOL FAN.
21. Press either the ► or ◀ button and the small fan inside the kick panel will operate.
22. This completes the check of most of the washer functions. Unlatch the door to exit from the Diagnostics mode.
23. To verify the proper operation of the overfill switch, repeat steps 1 & 2 above. Press either ► or ◀ button and allow tap water to enter the tank until the water flow turns off.
24. Press and hold the RUN button. Water will enter the washer and should turn off before it overflows.
25. Press the ▼ arrow until DRAIN/COOL is highlighted.
26. Press ► or ◀ button to drain water from the washer.
27. Unlatch the door to exit from the Diagnostics mode.

CHAPTER 4

USING YOUR WASHER

After your washer has passed the basic diagnostics test detailed in *Chapter 3: Getting Started*, you are ready to begin using your washer.

Arranging the Washer Racks

The FlaskScrubber and SteamScrubber are equipped with different rack configurations to accommodate the various types of laboratory glassware. In addition to the standard configuration of the Glassware Washers, many optional racks and inserts are available to customize your washer to best suit your needs. For a complete list of available rack accessories, refer to *Appendix A: Glassware Washer Accessories*.

If you purchased a SteamScrubber, proceed to the following section, *The SteamScrubber Racks*. If you purchased a FlaskScrubber, proceed to the section, *The FlaskScrubber Racks*, later in this chapter. A FlaskScrubber can be converted to a SteamScrubber by replacing the lower rack and adding an upper rack and slides. A spindle rack may be used in a SteamScrubber, though drying will be less efficient.

The SteamScrubber Racks

The SteamScrubber is equipped with a top rack and a bottom rack. Both racks are designed to accommodate inserts that hold flasks, beakers, culture tubes, graduated cylinders, Erlenmeyer flasks, petri dishes, watch glasses, BOD bottles, and a variety of other laboratory glassware. These inserts are sold separately and are detailed in *Appendix A*.

Removing the Upper Rack

The upper rack may be easily removed from the Glassware Washer to facilitate loading the rack outside the washer or to allow very tall glassware to be loaded and washed on the lower rack.

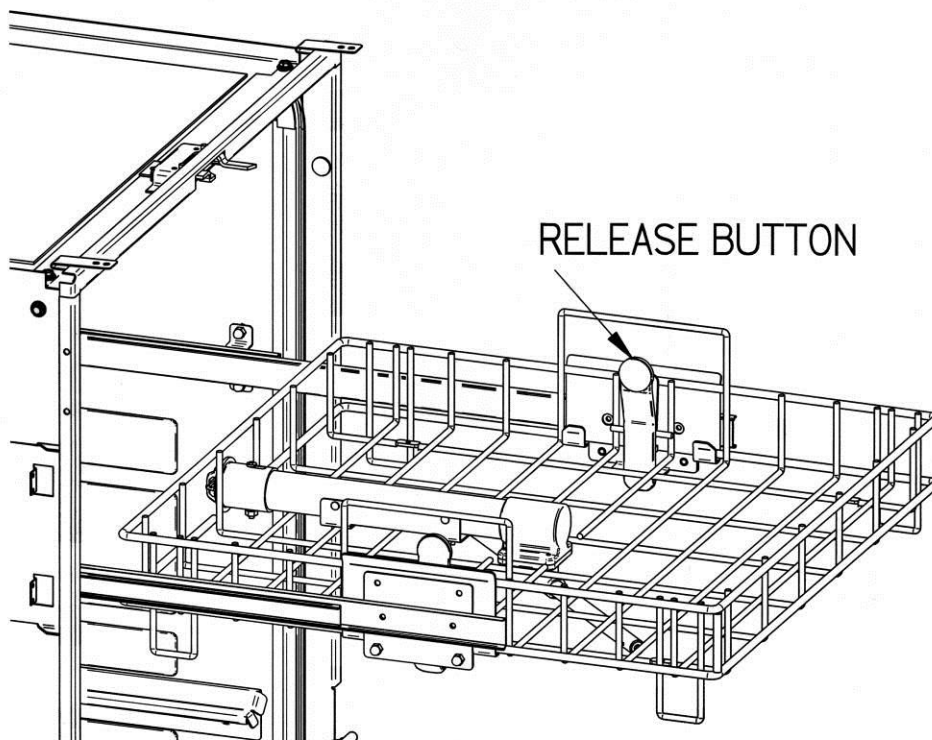

To remove the upper rack:

1. Slide the upper rack all the way out of the washer.
2. Grasp each side of the rack placing a thumb on the release buttons.
3. Press each release button and lift the rack straight upward.

To install the upper rack:

1. The upper rack can be replaced into the washer by first sliding each slide rail all the way out of the washer and then lowering the rack onto the rails.
2. Press down and the latch will automatically engage the rail.

The FlaskScrubber Spindle Rack

The FlaskScrubber Glassware Washer is equipped with a lower spindle rack and glassware holders. The FlaskScrubber spindle rack is designed for narrow-necked glassware such as volumetric flasks, Erlenmeyer flasks, graduated cylinders, Kjeldahl flasks, test tubes, and digestion tubes.

Two sizes of spindles are provided with the washer: thirty-six .25" (6.35 mm) OD and ten .125" (3.18mm) OD spindles. The optional Forty-Eight Pin Insert (Labconco P/N 4591601) may be positioned directly over spindles or spindles can be removed with a screw driver and replaced with the plugs included with the washer.

Optional top racks are available for the FlaskScrubber to expand the washer's capacity to accommodate many types of glassware. An Upper Spindle Rack (Labconco P/N 4595600) is available with 30 spindles.

Loading Glassware into the FlaskScrubber

Glassware Holders are supplied with each FlaskScrubber. These holders enable you to position glassware onto the FlaskScrubber spindles.

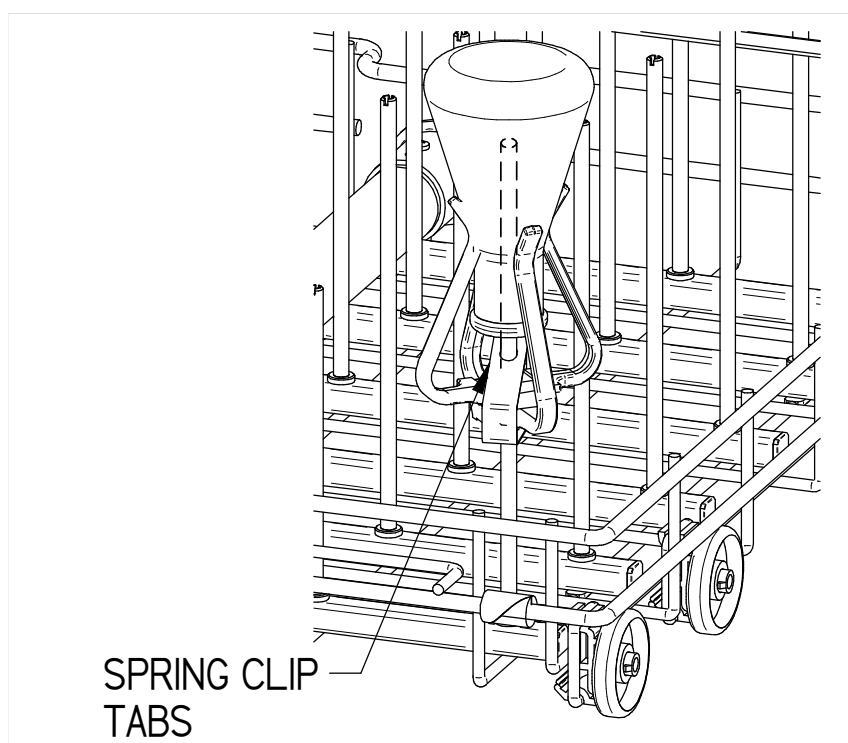

To use a Glassware Holder:

1. Press the glassware into the holder; the clamps should spring out and grip the glassware.
Note: It is normal for the clamps to deform if large glassware is inserted into the Holder and the washer is operated at high temperature. Do not use with glassware over 2.5 inches in diameter as damage to holder may occur.
2. The holder may be raised or lowered by squeezing the spring clip on the bottom of the holder and then sliding the holder up or down.
3. For best results, do not allow the glassware to rest directly on top of the spindle.

Glassware should be loaded so that it does not touch during a wash cycle. The washer has been designed for quiet operation. To prevent noise and glass breakage, be certain that glassware is retained.

The Detergent Dispenser

Your Glassware Washer is equipped with a detergent dispenser that contains a main wash cavity and a neutralizing solution port, as shown below. In addition, the washer door has a depression where detergent may be added for use during the first wash of the cycle.

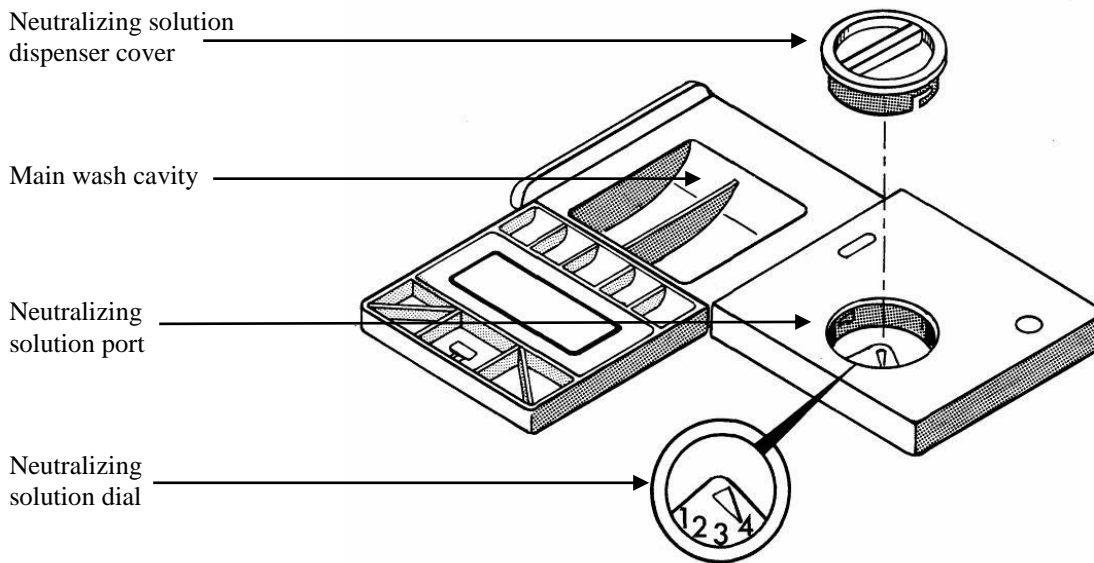





The detergent dispenser opens during the second wash cycle, except when the Plastic cycle is selected, which has only one wash cycle. If your glassware is heavily soiled, you may want to add powder detergent to the depression in the washer door. Do not use liquid detergent in the pre-wash cavity in the washer door. The initial drain and fill cycle flushes the liquid detergent out of the washer prior to the first wash. Refer to the table below to determine which cavities to fill, based on the selected wash choice. You may use either the pre-wash cavity stamped in the washer door or the one on the lid of the detergent cup.

Wash Cycle	Fill Pre-wash Cavity	Fill Main Cavity
Rinse Only	NO	NO
Plastic	NO	YES
All other cycles	OPTIONAL	YES



Do not use combustible solvents in the Glassware Washer. If soiled glassware contains flammable compounds, rinse the glassware thoroughly prior to placing the glassware into the washer. Heaters in the washer are very hot and could ignite flammable solvents.

	CAUTION HOT! Steam and surfaces within this washer and its contents may become hot enough to cause burns. Do not place any flammable liquids in this washer. Failure to empty and rinse glassware could result in fire or explosion.	
---	--	---

	ATTENTION CHAUD! La vapeur et les surfaces à l'intérieur de cette laveuse et son contenu peuvent devenir suffisamment chauds pour causer des brûlures. Ne placez aucun liquide inflammable dans cette laveuse. Il y a risque d'incendie ou d'explosion si la verrerie n'est pas vidée ni rincée.	
---	--	---



Petroleum based compounds may degrade certain internal washer components. Always thoroughly rinse petroleum based compounds from glassware before placing in the Washer.

Non-foaming powder or liquid detergent formulated for labware washers, in conjunction with adequate hot water, is essential for clean glassware. Labconco LabSolutions Detergents are recommended. See *Appendix A* for ordering information. Use detergents sparingly. Too much detergent, particularly with softened water may cause etching of the glassware. This appears as a permanent cloudy film on the glassware.

Fill the main detergent cavity three-fourths full if the water hardness grains per gallon (GPG) for your water measures 0-4 GPG (soft water). Fill the detergent cavity completely if your water measures 4 GPG or higher (medium to hard water). If you use the pre-wash cavity stamped in the washer door, fill it completely.

Note: To open the detergent dispenser, gently slide the white tab sideways. The tab may break if it is pulled upward or perpendicular to the door.

Store detergent in a cool, dry place. Immediately replace the detergent container lid after dispensing. If lumps develop due to exposure to moisture, discard the detergent according to local regulations.

Filling the Neutralizing Acid Dispenser

A mild or weak acid may be dispensed from the neutralizing solution port to neutralize the detergent alkalinity. Labconco LabSolutions Neutralizing Acid Rinse is recommended. See *Appendix A* for ordering information. The neutralizing acid rinse is dispensed during the first rinse. To avoid dispensing neutralizing acid during a purified water rinse, the total rinses should be greater than the number of pure rinses. The dispenser holds approximately 170 ml and should be checked and replenished as needed. To fill the neutralizing acid dispenser, refer to the figure above and follow the instructions below.

To fill the neutralizing acid dispenser:

1. Twist and pull up on the cap to remove the round cover on the neutralizing solution port.
2. Fill the cavity with LabSolutions Neutralizing Acid Rinse (Labconco P/N 4522200) 1M citric acid or 10% phosphoric acid until the level of the liquid rises and is visible in the port.
3. Set the dial to read 4 ml.
4. Replace the cover.

Selecting an Operating Cycle

The microprocessor control on your Glassware Washer allows you to select a factory programmed wash program, to modify the factory preset wash programs or to customize two additional programs. The control panel is shown below.

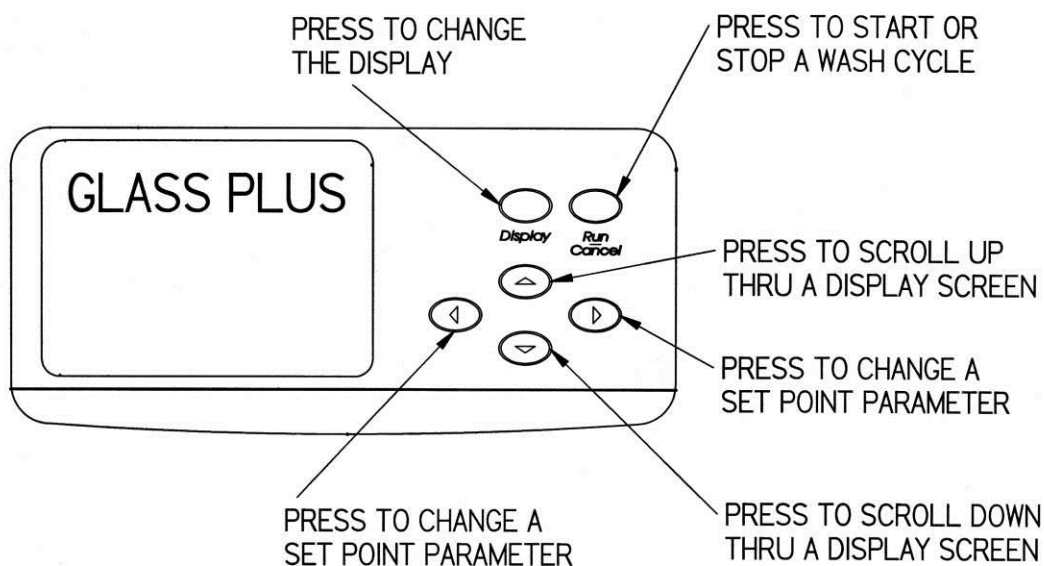

Programming and Starting a Wash Cycle

Refer to *Appendix C: Glassware Washer Specifications* for complete details on the various factory-set programs and the options available for customizing programs. After you have decided which washer program to use, follow the instructions below to start the washer.

Washers have the capability to wash glassware at high temperatures. Use care when selecting high-heat programs if plasticware is being washed.

Any of the standard factory wash programs may be customized to suit specific wash requirements. All changes made to the programs will be stored in the washer microprocessor's memory until it is changed again. If a **FACTORY RESET** is performed, all inputs entered by the user will be erased and the programs shipped with the washer will be reinstated. It is possible to customize the following program parameters:

- Wash 2 temperature
- Wash 2 time
- Total number of rinses
- Number of purified water rinses
- Final rinse temperature
- Enable or disable the steam function
- Dry temperature
- Dry time

In addition, when **USER 2** program is selected, it is possible to set:

- Wash 1 time
- Rinse time (all rinses will be the same time)

To program and start a wash cycle:

1. Close the washer door and slide the latch to the right. This energizes the electronic control and the display will show the last program that was run.
2. Press **RUN** to select this program.
3. If a different program is desired, press **DISPLAY**. The available programs will be shown on the display.

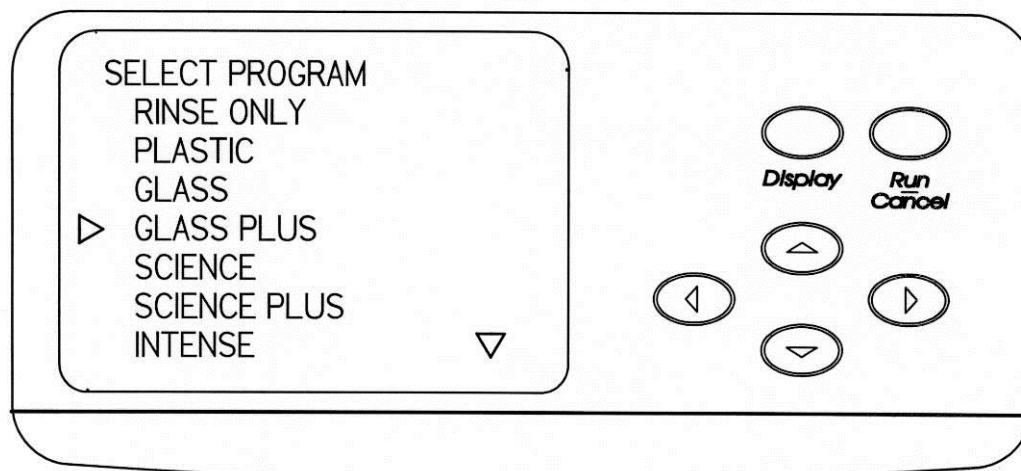

4. Press the ▲ or ▼ buttons until the desired program is indicated by the arrow on the left side. The arrow on the lower right side means that there are additional program selections that will be shown on the display if the ▼ button is pressed. If an arrow is visible in the upper right corner of the display, additional program selections will be displayed when the ▲ button is pressed.
5. Press RUN if no modifications to the program are necessary.
6. If modifications to the program are necessary or you want to see the parameters that are entered into the program, press DISPLAY and the elements in the program that may be altered will be displayed.

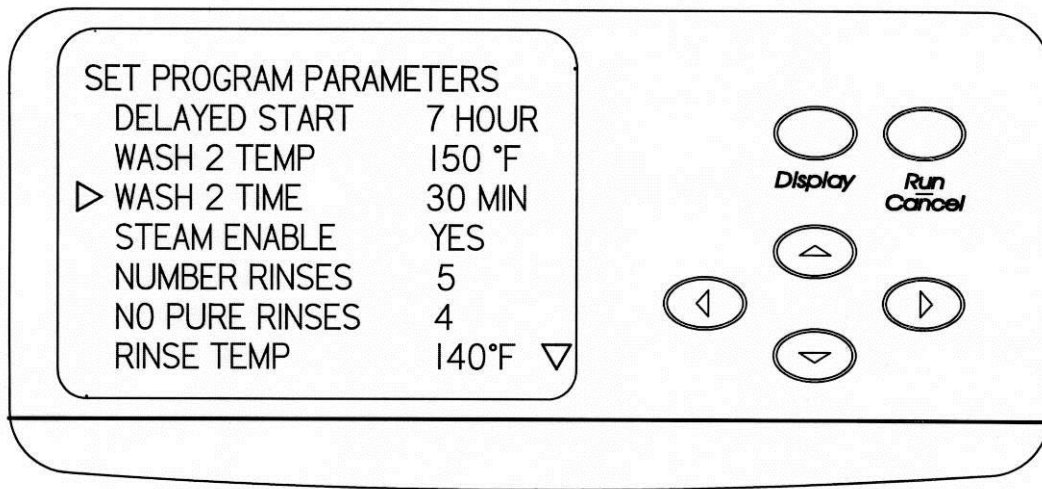

7. Press the ▲ and ▼ buttons to select the parameter that must be altered as indicated by the arrow on the left side. Press ◀ and ▶ buttons to select the appropriate set point. The arrow on the lower right side means that there are additional parameters selections that will be shown on the display if the ▼ button is pressed. If an arrow is visible in the upper right corner of the display, additional parameter selections will be displayed when the ▲ button is pressed.
8. Press RUN when all parameters are satisfactory.

Program Lock

After a program is selected and program parameters have been set, it is possible to lock those parameters into memory so they will not be inadvertently revised. This is done by first, entering the SELECT PROGRAM screen. Then scroll down and select the program that will be locked. Press the display key two times to display that program, then press and hold the DISPLAY key for 15 seconds. LOCK will be displayed in the lower right hand corner. As long as the program is locked, only that one program may be run. Lock is released by pressing and holding DISPLAY for 15 seconds.

Interrupting a Wash Cycle

To temporarily pause a wash cycle, simply unlatch the washer door. After the door is unlatched, wait 4 to 5 seconds before opening the door to prevent water from splashing out of the washer.

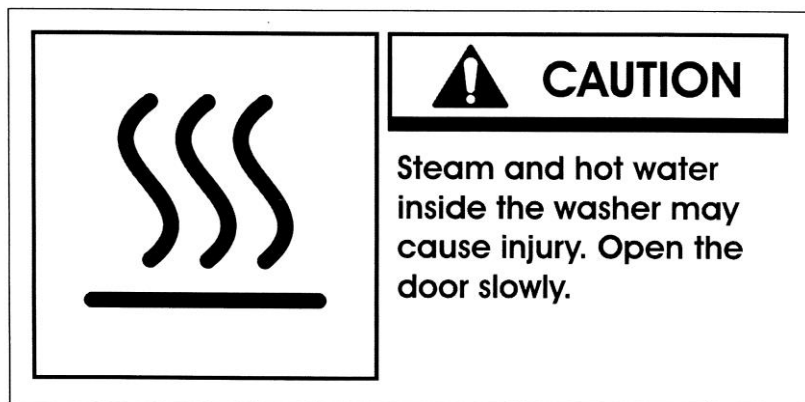

To resume the wash cycle, close and re-latch the washer door. The washer will pause to equalize temperatures and then the cycle will resume the interrupted segment.

The wash cycle can be terminated at any time by pressing the Start/Cancel button.

Alarms

Throughout a wash cycle there are several abnormal events that could occur. The washer is programmed to monitor these occurrences and provide an alarm to alert the operator. Information is shown on the display to identify the alarm situation. The following messages may be displayed. Certain alarm situations are signaled with an audible sound which self cancels after 1 minute.

HOT GLASS

This displays at the end of a cycle if the temperature inside the washer is over 122°F (50°C). The alarm cancels when the temperature cools.

PLEASE WAIT

This displays if the door is opened and then closed during a wash or rinse segment of a cycle. The display will also show the time remaining until the operation of the washer will resume where it was interrupted.

WATER LOW

This displays if a water fill is inadequate. The washer will cancel the cycle and drain water that is in the washer. The alarm is canceled by opening the door. See *Chapter 7: Troubleshooting* – Washer will not fill.

OVERFLOW

This displays if water is detected in the base of the washer. Water fill valves will be closed and the washer will cancel the cycle and drain water that is in the washer. The alarm is canceled by opening the door. See *Chapter 7: Troubleshooting – Washer leaks*.

LIQ DETER

This displays only if the optional liquid detergent dispenser is installed and the level of the detergent in the dispense container is low. The alarm is disabled if the detergent dispense volume is set to “0.” The alarm is canceled when detergent is added to the container.

DRAIN FAIL

This displays if water fails to completely drain during a normal drain operation. Operation of the washer is canceled. The alarm is canceled by opening the door.

LOW TEMP

This displays if the water doesn't reach the set point temperature within 135 minutes. Operation of the washer continues. The alarm cancels when the door is opened.

TEMP SENSOR

This displays if the temperature sensor is disconnected. It is canceled by connecting an operable sensor.

CHAPTER 5

MAINTAINING YOUR WASHER

Under normal operation, your Glassware Washer will require little routine maintenance to keep it functioning properly.

Maintaining the Stainless Steel Interior

The interior of your Glassware Washer is type 304 stainless steel. Never use metal scouring pads on the stainless steel interior. Metal scouring pads can scratch or leave metal chips that will rust.

To maintain the appearance and quality of the stainless steel interior, perform the following tasks as needed:

- Wipe the outer edges on the inside door panel to remove particles and residue that occur during loading.
- Use a sponge sprinkled with non-abrasive stainless steel cleaner to gently wipe the washer tank and door to remove surface discoloration caused by exposure to halogenated compounds or steel parts. In some cases, the finish may be slightly dulled by this action.

If your water has a high mineral content, film or spots may develop on the washer interior. If the procedures listed above do not eliminate the film or spots, you may run your washer through the special cycle below.

To remove film or spots from the washer interior:

1. Remove all glassware from the washer.
2. Choose the Glass Program, Steam OFF, Pure Rinse OFF, and set the drying time to zero.
3. After the first fill is complete, open the washer and carefully pour one cup of bleach into the bottom of the tank.

4. Close the washer door and allow the unit to wash and drain.
5. When the washer fills the second time, open the washer and add two cups of 4-8% acetic acid (or white vinegar) to the bottom of the tank.
6. Close the washer door and allow the unit to wash and drain without further interruption.

Maintaining the Air Gap in Drain

If the installation included an air gap (recommended) it requires periodic cleaning. The air gap is not part of the washer; therefore, it is not covered by the washer warranty. The air gap protects the washer against water backing up in the event of a clogged drain. Check the air gap for build-up any time your washer is not draining well.

Most types of air gaps are easy to clean. Simply follow the manufacturer's directions for maintaining your air gap.

Maintaining the Water Fill Valve

The filter screen of the water fill valve, illustrated below, may require periodic cleaning to remove trapped particles. A low water fill occurs if the blockage is not removed.

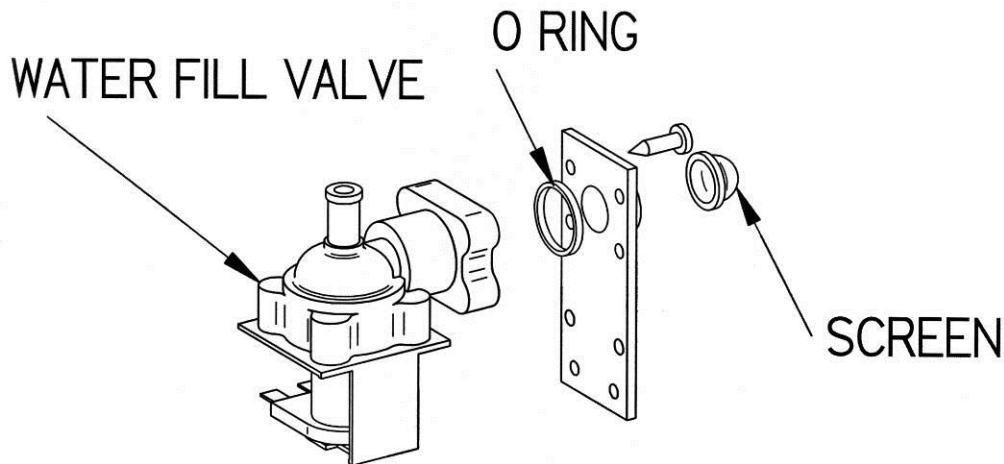

To clean the water fill valve:

1. Turn off the water and electrical power to the washer. Unplug the Mobile model; turn off the circuit breaker that services the Undercounter or Freestanding model.
2. Remove the rear panel of FreeStanding models.
3. Disconnect the water supply tube that is connected to the valve.
4. Remove the valve from the base.
5. Remove the four screws from the valve plate and separate the valve from the inlet connection.
6. Remove the valve filter screen and clean it under running water.

7. Replace the screen and reassemble the valve connection. Be certain the O-ring gasket is positioned in the groove in the fill valve body.

Removing the Washer Top, Back, and Side Panels

There may be times when you need to remove the washer top, back, and side panels to clean, maintain, or repair your washer. Refer to the figure below and follow the instructions to remove the top, back, and side panels of your washer.

To remove the washer top, back, and side panels:

1. Turn off electrical power to the Glassware Washer.
2. Remove all of the screws from the back panel of the washer and remove the back panel.
3. Remove the 2 screws at the kick panel.
4. Remove 2 screws at the rear that hold the sides to the top.
5. Remove the two screws from each side of the washer at the front edge.
6. Remove the side panels.
7. Remove the 2 screws that hold the top.
8. Remove the top.

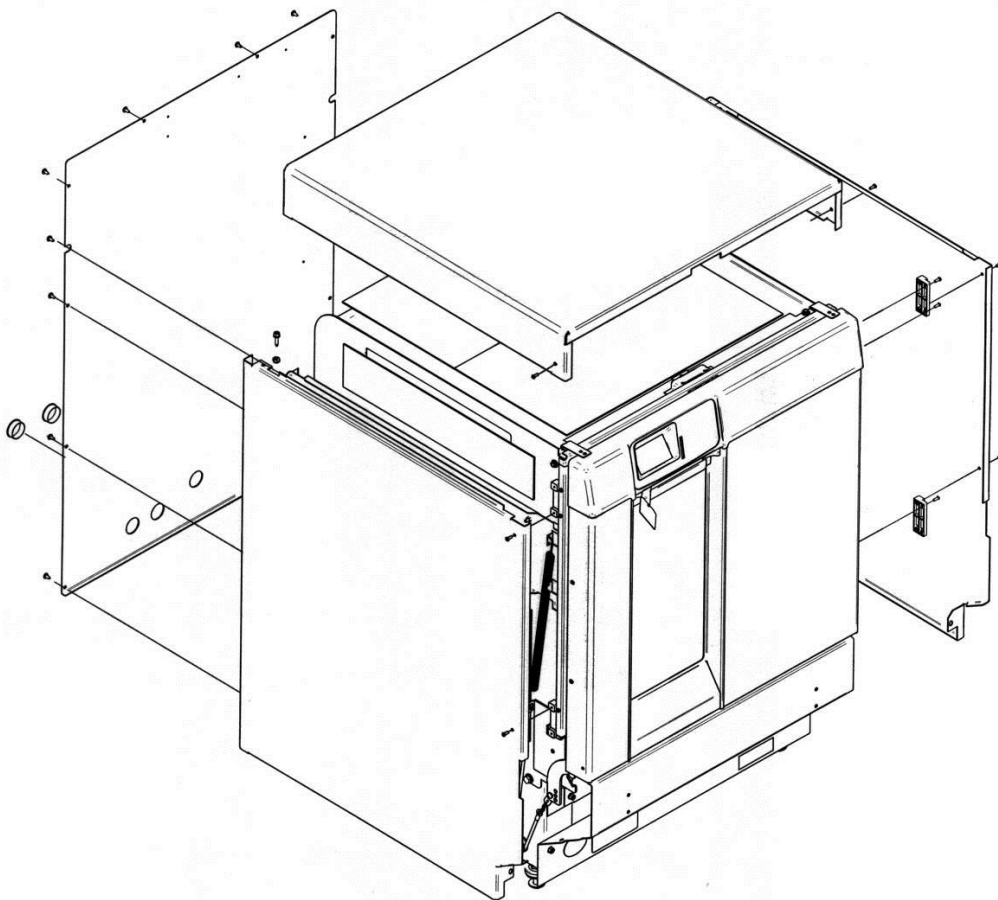

Cleaning the Sump Filter Screen

If debris accumulates on the filter screen that is located in the washer sump, you can remove and clean the screen. To clean the sump filter screen, refer to the figure below and follow the instructions below.

To clean the sump filter screen:

1. Open the washer door and remove the bottom rack.
2. Remove the screw that retains the filter screen.
3. Carefully lift the screen and pull forward, using care not to drop debris into the sump.

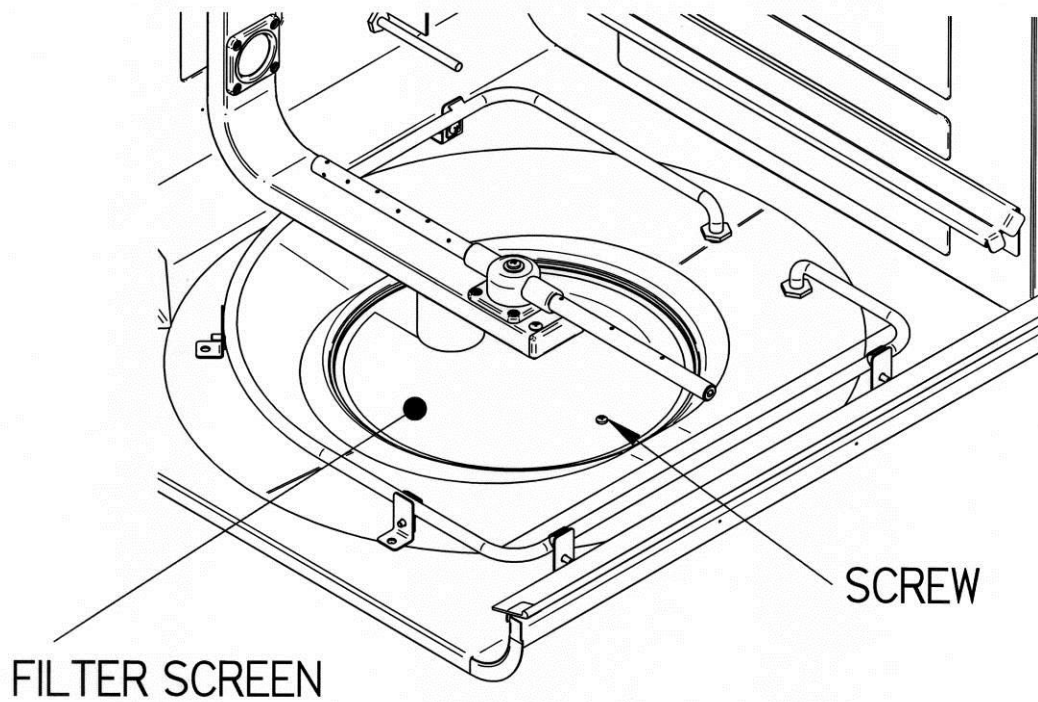

CHAPTER 6

MODIFYING YOUR WASHER

The configuration of your washer may be changed to accommodate your needs. For example, you may want to install pipet inserts, install an optional top rack, or install an optional liquid detergent dispense system or Cool Drain Water Kit. Refer to *Appendix A: Glassware Washer Accessories* for the accessories that are available for your Glassware Washer.

Adjusting the Height of the Upper Rack

The height of the upper rack may be varied to suit the heights of glassware that will be washed in the upper and lower racks.

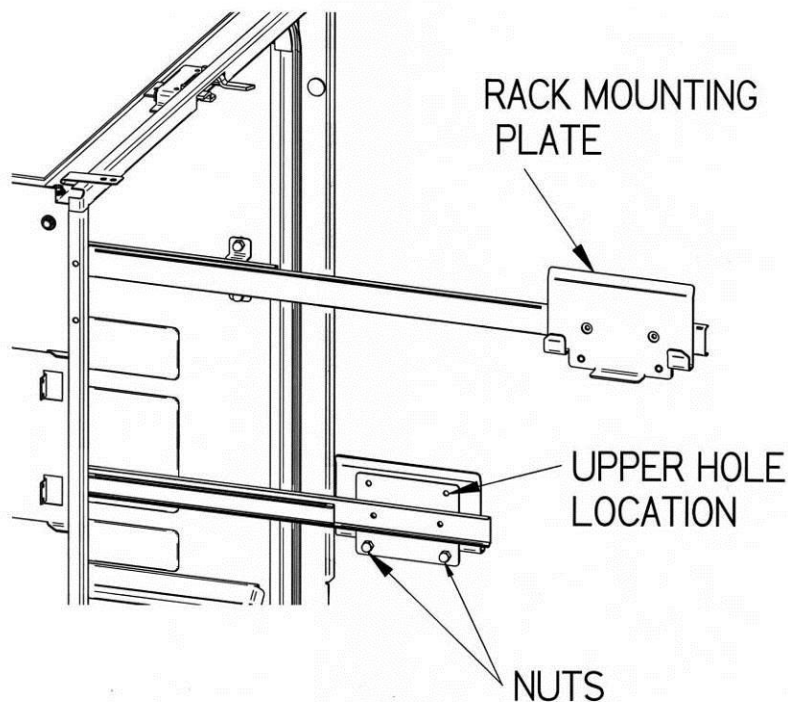

To adjust the height of the upper rack:

1. Remove the upper rack as described in *Chapter 4: Using Your Washer*.
2. Remove the 2 nuts that retain the rack mounting plate to the slide.
3. Reposition the rack mounting plate to the slide using the other set of holes.
Replace the 2 nuts.
4. Repeat the procedure on the opposite slide.

Spindle Rack Options

If you purchased a FlaskScrubber Glassware Washer, you can modify the configuration of your washer to better suit your needs. Optional accessories include two Pipet Inserts, and an Upper Spindle Rack. The Pipet Inserts are easily installed in place of one or more spindles in the washer and are designed to accommodate 1 ml to 50 ml pipets.

Installing Optional Pipet Inserts in a FlaskScrubber

Two sizes of Pipet Inserts are available. The 8-place Pipet Insert, shown below accommodates 1 ml to 10 ml pipets. Multiple Pipet Inserts may be installed, if desired. Refer to the figure and follow the instructions below to install an 8-place Pipet Insert.

To install an 8-place Pipet Insert:

1. Insert the tool supplied with the Spindle Rack or a screwdriver into the top of a spindle and turn counterclockwise to remove the spindle.
2. In the position previously occupied by the spindle, thread into place the short spindle you received with the Pipet Insert.
3. Push the Pipet Insert over the short spindle.
4. If spindles other than the one used for the short spindle are removed, the holes must be plugged with the plastic plugs supplied with the spindle rack.

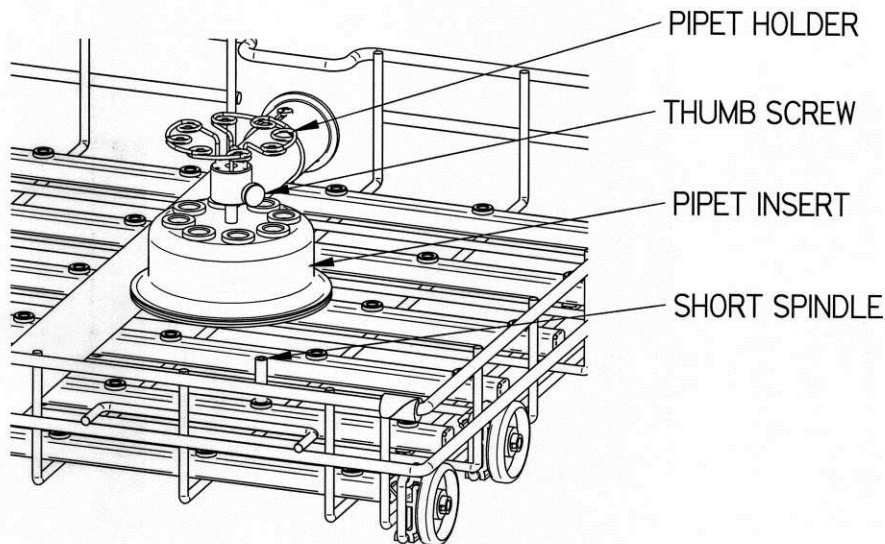

The 16-place Pipet Insert, shown below accommodates 1 ml to 50 ml pipets. Two of these inserts may be installed, if desired. Refer to the figure and follow the instructions below to install a 16-place Pipet Insert.

To install a 16-place Pipet Insert:

1. Use the tool supplied with the Spindle Rack or a screwdriver to remove the six spindles on either the right or left side of the spindle rack. Remove others if necessary.
2. Replace the six spindles with the six short spindles that you received with the Pipet Insert.
3. Replace all other spindles with the plastic plugs that you received with your washer.
4. With the support facing the center of the spindle rack, slide the Pipet Insert over the spindles until it completely seats.
5. Push pipets into the 16 receptacles and rest them on the support.

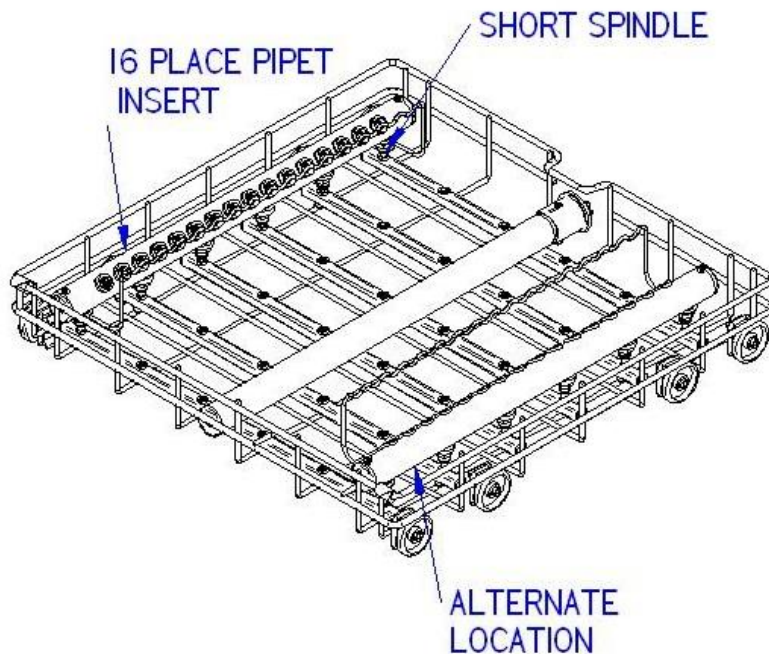

Note: Lower spindle racks are shipped with 34 long spindles and 2 shorter spindles. If spindles are removed and then replaced, the shorter spindles should be located on the front row in the second and third positions from the right side. This will allow proper function of the detergent dispenser.

Installing the Optional Upper Spindle Rack

The Upper Spindle Rack expands the capability of the FlaskScrubber by providing 30 additional spindles for washing narrow-neck glassware. The rack may be customized by removing spindles or by installing Multi-Pin Inserts which hold beakers or other wide mouth glassware.

To install the optional Upper Spindle Rack:

Install the upper rails and the upper spindle rack. See the figure below.

1. Remove the acorn nuts and lockwashers from both upper sides using a 3/8" wrench. There are 4 on each side.

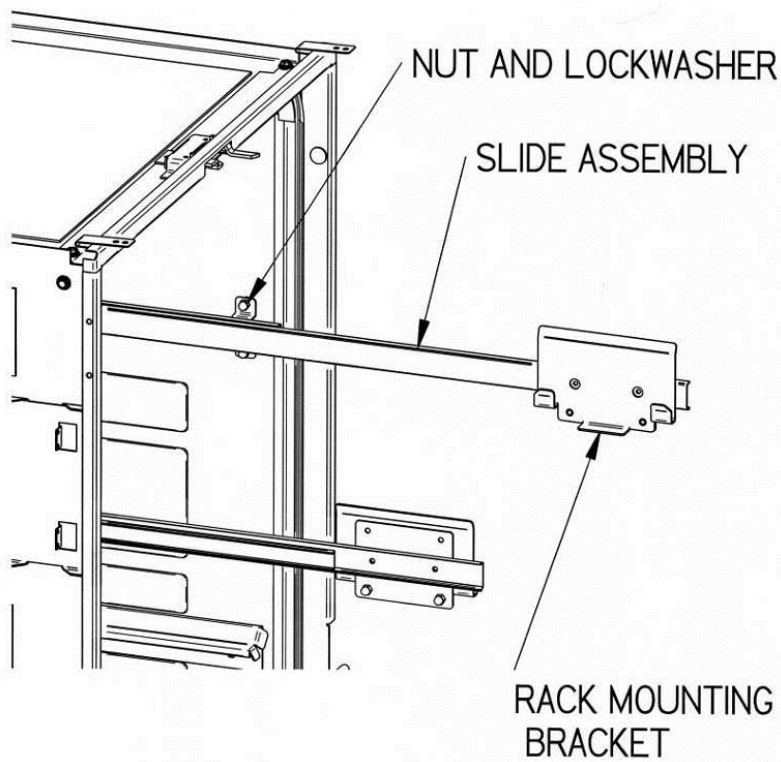

2. Position brackets on slides over the studs on the sides. The position of the rack mounting plates must be as shown. Secure the slide assemblies using lockwashers and acorn nuts removed in Step 1. It may be necessary to synchronize the travel of the two slides. Pull each slide out firmly to their maximum travel.

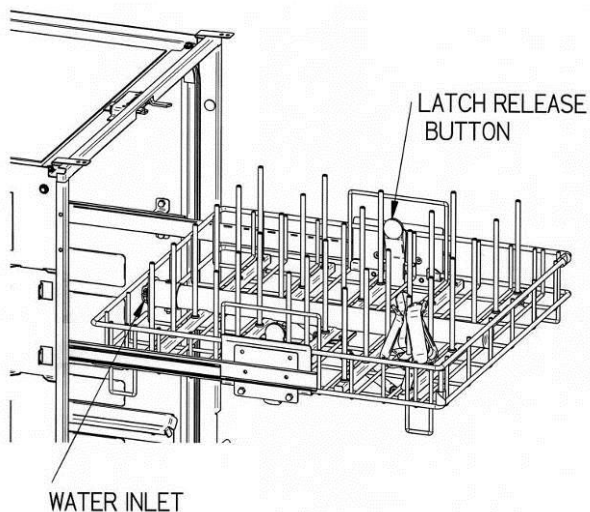

3. Install the Upper Spindle Rack by lowering the rack onto the rack mounting plates. The water inlet must have its inlet toward the rear. Make sure the latch on each side secures the rack to the rack mounting plate.

When the Upper Spindle Rack is in place, it limits the height of the glassware that can be washed. If very tall glassware or long pipets are to be washed, remove the Upper Spindle Rack.

Installing Optional Inserts into the Spindle Rack

A Multi-Pin insert is available that can be placed directly on the FlaskScrubber upper or lower spindle rack. It can hold beakers or wide mouth glassware. The insert can be positioned either on the left side or right side.

To install an insert:

1. Remove all glassware, spring retainers and glassware holders.
2. Lower the insert down over the spindles. If necessary, spindles may be removed using the tool supplied with the Spindle Rack or a screwdriver in the slot on the top of the spindles. Be sure to replace any removed spindle with a plug supplied.

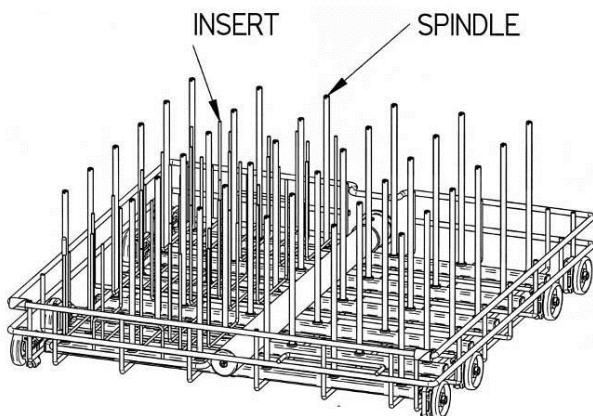

Installing Small Spindles

Ten small spindles are included with each Spindle Rack. Since the large volume of water which flows through the standard spindles may be great enough to force the glassware off the spindle, small spindles should be used when small pieces of glassware will be washed.

To install small spindles:

1. Remove the standard spindle by inserting the tool supplied with the Spindle Rack or a screwdriver into the slot on the top and turning counterclockwise.
2. Replace the standard spindle with a small spindle.

Installing the Optional Cool Drain Water Kit

An optional Cool Drain Water Kit is available to reduce the water temperature of the drain water in installations where hot drain water is not permitted. It may be installed on Undercounter or Freestanding models. A supply of cold water must be available. It is recommended that the cold water temperature is colder than 54°F (12°C). Warmer water temperature will cause the drain temperature to be higher. The cold water supply must be capable of a flow rate of 3.5 GPM (13.2 LPM) and a pressure of 20-120 PSI (138-827 kPa). Hot drain water will be mixed with cold water during drain operations. To install the optional Cool Drain Water Kit, refer to the figure below and the following instructions.

To install the optional Cool Drain Water Kit:

1. Disconnect power to the washer.
2. Remove the back panel of the washer if it is a Freestanding model or the cover panel of an Undercounter model.
3. Attach the water valve assembly to the rear flange of the base using the screws provided.
4. Connect the wires coming from the water valve assembly to the mating connector in the wiring harness of the washer.
5. Connect the cold water supply to the water valve assembly. Do not allow the tube to kink when the washer is placed into its operational location. If necessary, replace the straight fitting on the cool water valve with the supplied elbow.
6. Replace the back panel if it is a Freestanding model or the cover panel if it is an Undercounter model.
7. Attach the hose from the valve to a Twin Inlet High Flow Air-gap suitable for dishwasher applications. This may be obtained from a plumbing supply store.
8. Attach the drain hose from the Glassware Washer to the other inlet of the Air-gap.
9. Attach the Air-gap to the building drain.
10. Turn on the electrical power.

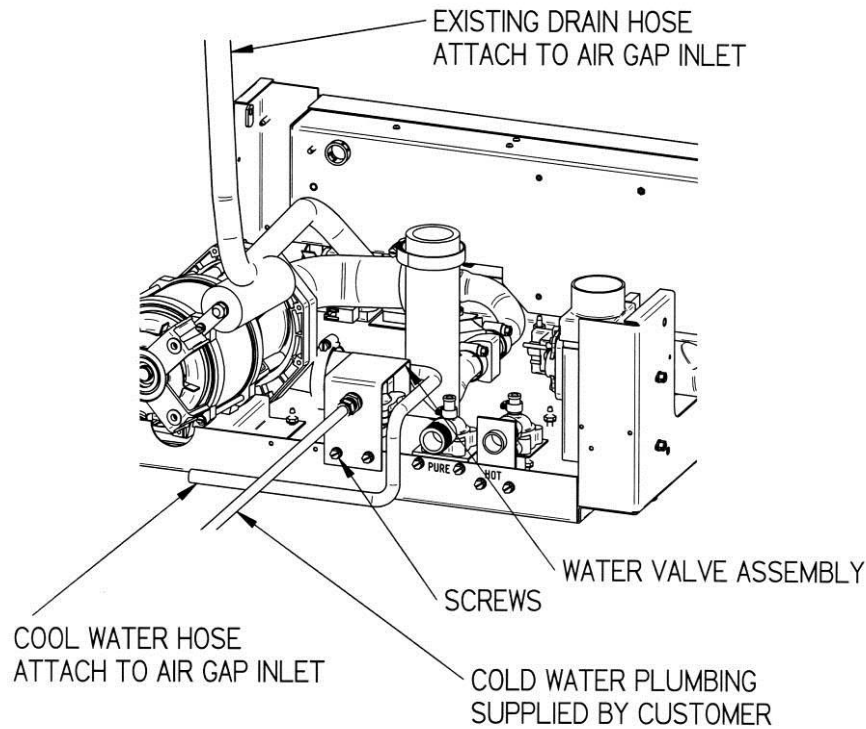

TANK AND OTHER PARTS NOT SHOWN FOR CLARITY

Installing the Optional Liquid Detergent Dispenser

An optional liquid detergent dispenser is available for installation on SteamScrubbers and FlaskScrubbers. This permits dispensing liquid detergent from a bulk 1 gallon (3.8 L) container eliminating the need to fill the detergent cup with detergent each time the washer is used. To install the liquid detergent dispenser, refer to the figures below and the following instructions.

To install the liquid detergent dispenser components:

1. Disconnect power to the washer.
2. Remove the back panel if the washer is a Freestanding model. Loosen the insulation blanket to provide access to the back of the washer.
3. Attach the dispense pump to the rear flange of the base using the screws and nuts provided.
4. Attach the tube from the detergent container to the inlet of the pump.
5. Route the tube from the pump outlet to the vacuum break on the right hand side of the washer. Connect the tube to the .12 barb fitting on the side of the vacuum break. Secure the provided tie wrap around all 3 tubes on the top of the vacuum break being careful not to collapse any tube.
6. Locate the detergent container at a convenient location where it will not be a trip hazard.
7. Remove the lower panel and the electrical junction box cover as described in *Chapter 3: Getting Started*.

8. Plug the supplied harness into terminal J6 on the Relay PCB and route the other end to the left rear corner of the washer base.
9. Plug the wire from the detergent container to the mating connector in the new harness in the base of the washer.
10. Plug the connectors on the pump to the mating connectors in the new harness in the base of the washer.
11. Reinstall the junction box cover and lower panel.
12. Reinstall the back panel if the washer is a Freestanding model.
13. Turn on the electrical power.

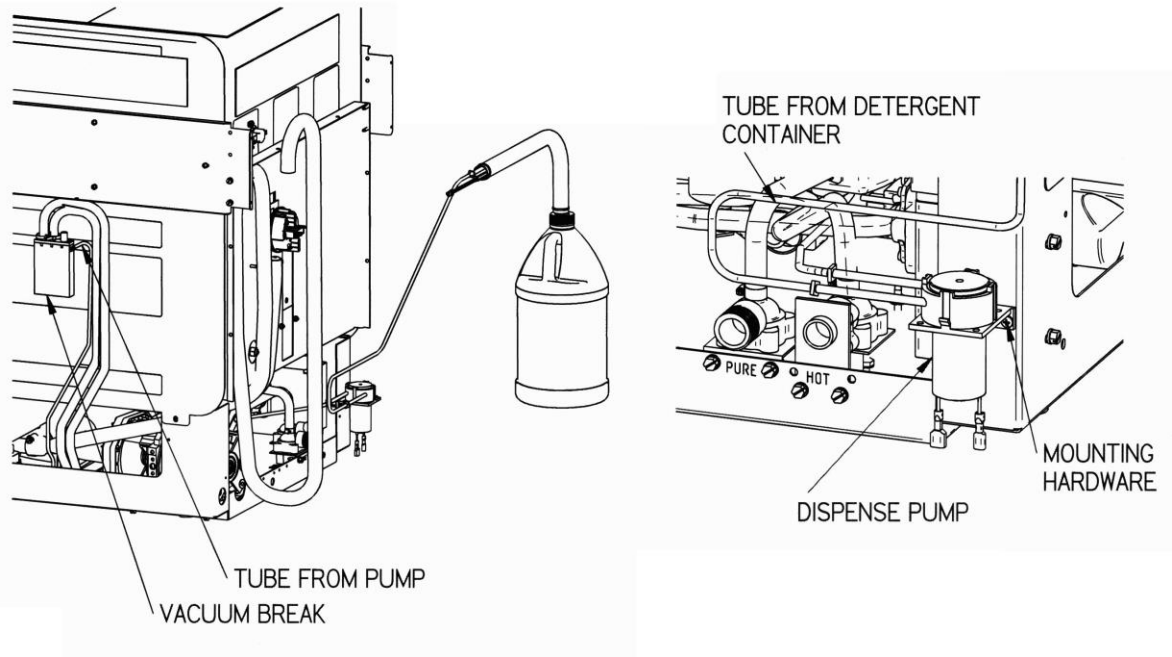

Enable the liquid detergent dispenser operation:

1. Enter the washer set up screen on the display by holding the ▼ button on the control panel and closing the door and sliding the door latch to the right.
2. Press the ▼ button until the arrow on the left points to LIQ DETERGENT OPT.
3. Press the ► or ◀ button to activate this accessory.
4. Press RUN to save all settings.

Using the liquid detergent dispenser:

1. Remove the cap from the container and remove the tube and level switch assembly.
2. Fill the container with detergent or use a new bottle of Labconco detergent and replace the tube and switch assembly and the cap.
3. There are two methods which can be followed for filling the system with detergent.
 - a. Run a wash cycle with no glassware in the washer. Set the detergent dispense rate to 30 ml.
 - b. Run a diagnostics test. When the display window shows DETERGENT PUMP, allow the pump to run for 30 seconds.
4. Program the quantity of detergent that will be dispensed by entering the programming screen as described in *Chapter 4: Using Your Washer*.

CHAPTER 7

TROUBLESHOOTING

Refer to the following table if your Glassware Washer fails to operate properly. If the suggested corrective actions do not solve your problem, contact Labconco Product Service for additional assistance.

PROBLEM	CAUSE	CORRECTIVE ACTION
Detergent cup fails to open	Malfunction of cup	Replace cup.
	Malfunction of relay	Check electrical continuity or replace PCB.
	Glassware interfering with cup door	Move glassware.
Noises during operation	Glassware rattling	Load glassware properly. Do not allow glassware to touch.
	Door panel vibrating	Tighten panel screws.
	Wash arms hitting	Check glassware loading.
	Water inlet line makes occasional hammering sound	Check with plumber.
	Purified water pump is activated	No corrective action needed. This is normal for about 5 minutes while pure water enters the washer.
Door drops too far (below door stop)	Bent door hinge	Replace door hinge.

PROBLEM	CAUSE	CORRECTIVE ACTION
Poor drying	Dry temperature too low	Program warmer dry temperature.
	Flask, beaker, or labware with concave bottoms not loaded correctly	Tilt these articles when loading so that water drains off.
	Recondensation	If clean labware is left in the washer, recondensation may occur. Open latch after completion of cycle to allow moisture-laden air to escape.
	Heater(s) disconnected or malfunctioned	Reconnect or replace heater.
	Blower disconnected or malfunctioned	Reconnect or replace blower.
	Dry time too short	Program longer time.
	Temperature sensor out of calibration	Verify displayed temperature by attaching a thermocouple to the temperature sensor. Route leads outside of the washer. Close and latch the door while holding the ◀ button. Call Labconco Product Services if the displayed temperature differs from the test temperature by more than $\pm 4^{\circ}\text{C}$.
Poor washing results	Water is not hot enough	Check Wash 2 water temperature. Must be at least 120°F (49°C). Recommended temperature is 150°F (66°C).
	Improper loading	Check washer loading instructions in <i>Chapter 4</i> in this manual.
	Detergent too old or amount wrong	Replace detergent or change quantity used.
	Detergent caked in cup	Clean cup. Replace with fresh detergent. Check water inlet temperature. Must be at least 120°F (49°C).
	Insufficient wash time	Increase wash cycle time.
	Insufficient water	Check to be sure the water shut-off valve is fully open. Check to be sure the water pressure is between 20 and 120 psi (138-827 kPa) at a flow rate of 1.25 (4.7 Liters/min) gallons per minute. Check water level switch.
Not draining properly	Clogged filter	Clean sump filter.
	Drain line clogged or kinked	Disconnect drain line and clean or remove kink.

PROBLEM	CAUSE	CORRECTIVE ACTION
Purified water does not fill	Crimp in supply hose	Refer to installation instructions for proper purified water piping installation.
	Motor wires disconnected	Reconnect wires.
Tank and inner door have surface rust	Collects normally	Clean with stainless steel cleaner and soft cloth.
	Glassware is contaminated with mineral acids.	Pre-rinse glassware. Clean with stainless steel cleaner and soft cloth.
Washer does not run	No power to washer	Check fuse or circuit breaker, or door switch.
	Door latch is open	Latch washer door by pushing door in.
Washer door opens and closes badly	Cabinet opening is not square	Correct opening with leveling feet.
	Door hitting counter-top mounting screws	Adjust mounting screws.
Washer leaks	Washer is not level	Adjust leveling feet.
	Door not sealing	Adjust door latch.
	Tank gasket loose	Check gasket and correct.
	Loose connection at hose clamps	Tighten hose clamp.
	Loose connection at fill valve	Check fill valve and correct.
	Improper detergent	Use non-foaming detergent. Use only proper amount of detergent.
	Obstruction in drain line	Remove obstruction.
	Washer overfilling	Check operation of fill switch.
Washer leaks around door seal	Improper installation	Check cabinet opening to see if it is aligned properly with the door. Washer must be level. Adjust feet to level unit.
	Unit not level	Adjust feet to level unit.
	Door opened during operation	Allow 4-5 seconds before opening door after unlatching.

PROBLEM	CAUSE	CORRECTIVE ACTION
Washer will not drain	Clogged drain	Clean out drain.
	Blockage of air gap	Clean the air gap by lifting the cover, unscrewing the cap, and removing any accumulated material. See <i>Chapter 5</i> .
	Kink in drain hose	Check for a kink in the drain hose.
	Filter blocked	Check filter in washer and clean as needed.
	Drain valve or pump not operating	Check operation.
Washer will not fill	Fill valve clogged	Clean fill valve.
	Water supply turned off	Turn on water.
	Defective fill switch	Check operation.
Washer overfills	Defective fill switch	Check operation.
Selection buttons on control panel inoperable or controls malfunction	Microprocessor memory error	Perform "Factory Reset." Open latch on door. Press ▼ button and simultaneously close door latch. Release ▼ button and display will show the set up screen. Press ▼ until FACTORY RESET is highlighted. Press ► or ◀ until "Yes" is displayed. Press RUN.
	Key pad defective	Replace key pad.
Drain Fail Alarm	Drain Valve inoperable	Listen for click when washer should drain.
		Check for mechanical restriction of actuator arm on top of valve.
		Check for electrical power to valve.
	Drain Pump inoperable	Check for damage to valve coil.
		Check if pump fan turns when washer should drain.
		Check for mechanical restriction of fan.
Drain hose not routed properly	Check for electrical power to pump.	
	Hose from drain pump must slope upward and have no low spots or horizontal runs under washer tank. Make sure hose is attached to the back of the washer and has a high loop.	

PROBLEM	CAUSE	CORRECTIVE ACTION
	Drain hose not routed properly (cont.)	Hose must be attached to building plumbing pipe ¾ inch ID or larger. Hose from washer must not be attached to another hose. Check for kinks in hose. Drain hose must not be elevated more than 30 inches.
	Pump lost its prime	Remove ALL water from inside drain hose. Pump will prime when water drains from washer.
	Building plumbing defective	Check for blocked air gap. Check for clogged drain.
	Filter screen clogged	Clean screen in bottom of washer.
	Defective fill level switch	Contact Labconco Product Service.
	Defective controller	Check output from PCB to drain valve and pump. Replace PCB. Contact Labconco Product Service.
Water Low Alarm	Improper water supply	Make sure water is turned on. Tap water pressure must be at least 20 psi (138 kPa) and flow must be at least 1.25 gallons (4.7 liters)/minute. DI water supply must have flow of at least 0.9 gallons (3.4 liter)/minute.
	Improper water supply (cont.)	At least 3.4 gallons (13 liters) must be available for each DI rinse.
	Defective fill valves	Clean screens inside the inlet fittings of the water valves. Check voltage to valves. Replace valve if it does not operate.
	Restricted flow	Check for kinks in water hoses in base of washer to water inlet fitting on side of tank.
	Defective DI water pump	Check voltage at pump. Listen for pump operation. Replace if necessary.

PROBLEM	CAUSE	CORRECTIVE ACTION
	Defective hose to fill switch	Check for splits. Check for loose clamps.
	Defective fill level switch	Recalibrate switch. Contact Labconco Product Service. Replace switch.
	Defective controller	Check output from PCB to both valves and DI pump. Replace PCB. Contact Labconco Product Service.
	Holes in filter screen too small	Contact Labconco Product Service.
	Defective grommet where hose connects to fill level switch	Replace grommet.
Low Temp Alarm	Heater inoperative	Check electrical connections. Check voltage to heater. Check resistance of heater. If open circuit, replace heater.
	Defective controller	Check output from PCB to heater. Replace PCB. Contact Labconco Product Service.
	Defective temperature probe	Check electrical connections. Contact Labconco Product Service. Replace if necessary.
	Defective high temperature cut out switch	Check resistance of safety cut out switch. If open circuit at room temperature, replace switch.

APPENDIX A

GLASSWARE WASHER ACCESSORIES

FlaskScrubber Accessories

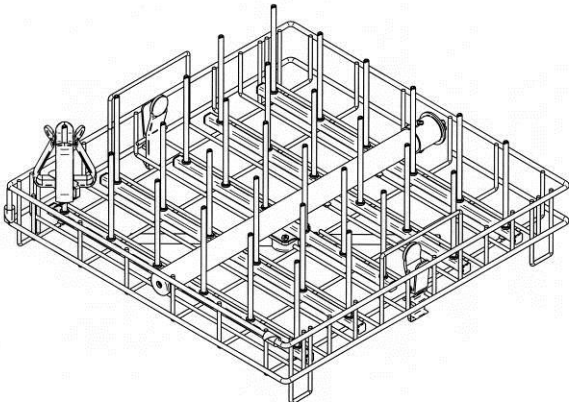
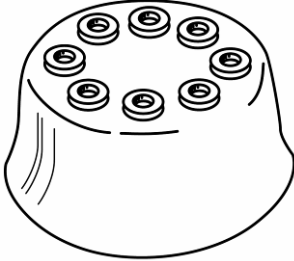
PART #	DESCRIPTION	
4595600	Upper Spindle Rack – Stainless Steel. Contains one upper spindle rack with 30 spindles, 30 glassware clips, 15 plastic glassware holders and 2 slides.	
4595800	Same as above except without slides.	
4494200	8-Place Pipet Washer – Stainless Steel. Holds 1 ml to 10 ml pipets.	

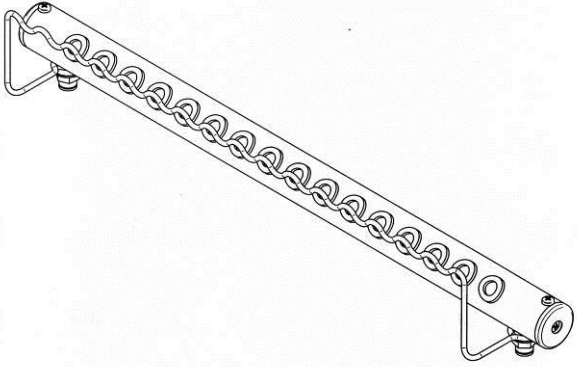
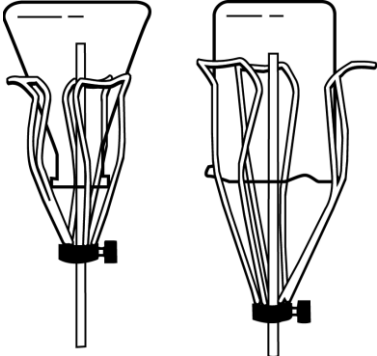
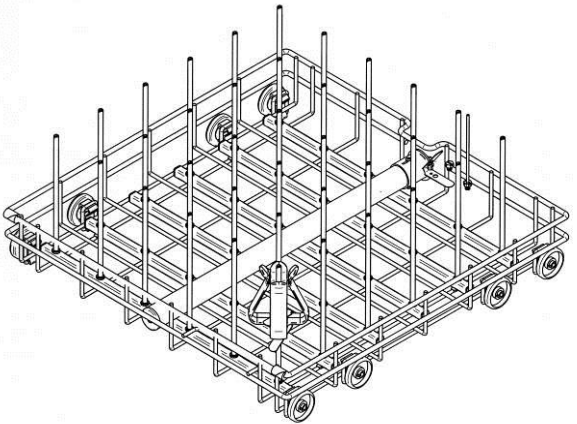
PART #	DESCRIPTION	
4595200	<p>16-Place Pipet Washer – Stainless Steel. Holds 1 ml to 50 ml pipets.</p>	
<p>4424600</p> <p>4424800</p>	<p>Glassware Holder – Small. Grips wide-mouth glassware over spindles. Vinyl coated stainless steel wires.</p> <p>Glassware Holder – Large. Grips wide-mouth glassware over spindles. Vinyl coated stainless steel wires.</p>	
4596000	<p>Small Spindles with Clips. Replaces larger spindles when washing small glassware. 10 spindles, 10 clips, 36 plugs.</p>	
4595700	<p>Lower Spindle Rack – Stainless Steel. Contains 36 spindles, 18 plastic glassware holders and 36 glassware clips. Included with FlaskScrubbers.</p>	

FlaskScrubber or SteamScrubber Accessories

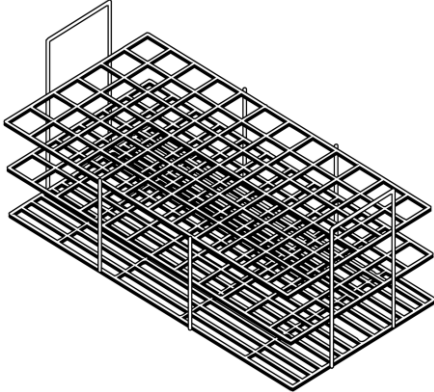
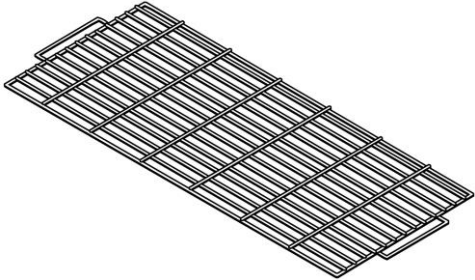
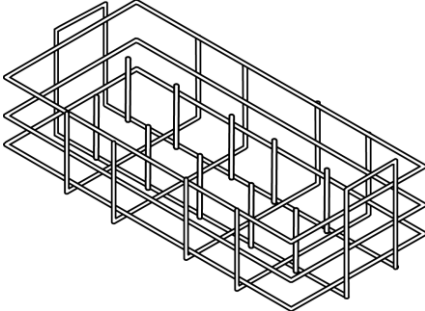
PART #	DESCRIPTION	
4402001	<p>Culture Tube/Test Tube Insert – Stainless Steel. Insert for 15 mm to 18 mm tubes.</p>	
4402101	<p>Culture Tube/Test Tube Insert – Stainless Steel. Insert for 20 mm to 25 mm tubes.</p>	
4401301	<p>Culture tube/Test Tube Insert – Stainless Steel. Insert for 10 mm to 12 mm tubes. Includes retainer top 4401401.</p>	
4401401	<p>Retainer Top for Culture Tube Insert – Stainless Steel. For use with all culture tube inserts to keep lightweight tubes in place under water pressure.</p>	
4401501	<p>10-Pin Insert – Stainless Steel. For use with beakers, Erlenmeyer flasks, and other wide-mouth glassware.</p>	

Appendix A: Glassware Washer Accessories

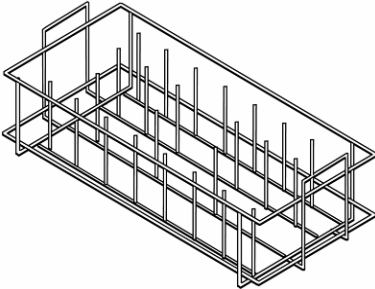
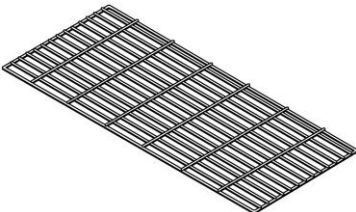
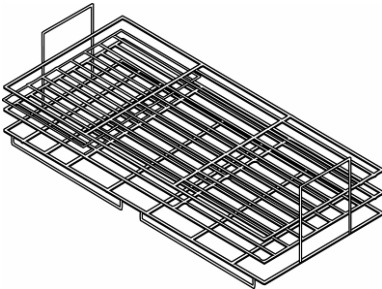
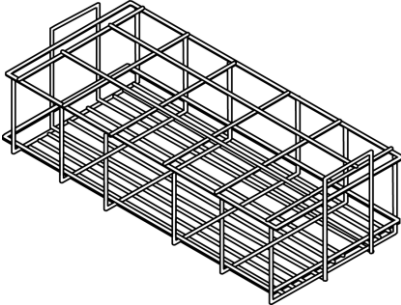
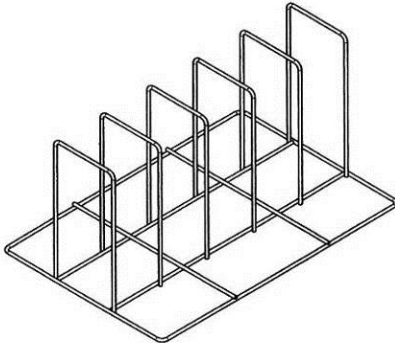
PART #	DESCRIPTION	
4401801	<p>32-Pin Insert – Stainless Steel. For use with beakers, Erlenmeyer flasks, and other wide-mouth glassware.</p>	
4401901	<p>Retainer Top – Stainless Steel. To keep lightweight flasks in place under water pressure. For use with 4401801 or 4401501.</p>	
4589701	<p>Petri Dish Insert – Stainless Steel. For plates, petri dishes, and watch glasses.</p>	
4589201	<p>BOD Rack/Beaker/ Erlenmeyer Flask Insert – Stainless Steel. Rack secures glassware used in oxygen-demand determination, beakers, and Erlenmeyer flasks.</p>	
4598401	<p>Tray Holder. For trays up to 19 x 19 x 2.5 deep (48 x 48 x 6 cm deep)</p>	

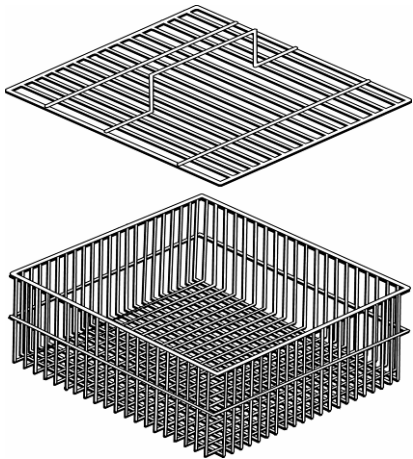
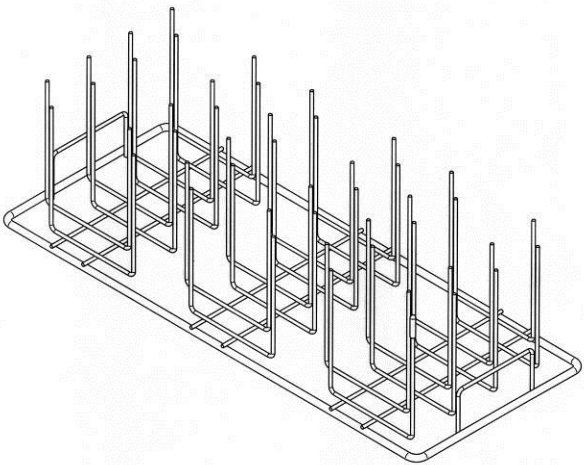
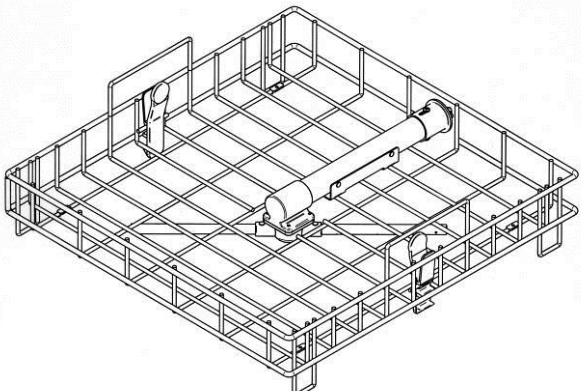
PART #	DESCRIPTION	
4402201	<p>Utensil Basket – Stainless Steel. For miscellaneous labware such as stoppers, spatulas, small beakers, etc. Furnished with drop-in cover (part number 4493801).</p>	 <p>The diagram shows two views of a stainless steel utensil basket. The top view is a flat, rectangular wire mesh cover. The bottom view is a rectangular wire mesh basket with a flat base and vertical sides, designed to hold various laboratory tools.</p>
4591601	<p>48-Pin Insert – Stainless Steel. For use with beakers, Erlenmeyer flasks, and wide-mouth glassware. For placement in bottom or upper rack.</p>	 <p>The diagram shows a rectangular stainless steel insert with 48 vertical pins of varying heights. The pins are arranged in a grid pattern, designed to hold glassware like beakers and flasks upright for cleaning.</p>
4587000 4595900	<p>Top Rack – Stainless Steel. Included with SteamScrubbers.</p> <p>Top Rack – Stainless Steel. Includes 2 slides for installation in FlaskSrubber.</p>	 <p>The diagram shows a rectangular stainless steel top rack. It features a grid of horizontal and vertical bars. Two long, cylindrical slides are shown inserted into the grid, used for mounting the rack into a larger washer frame.</p>

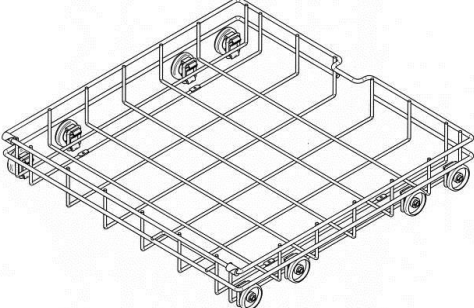
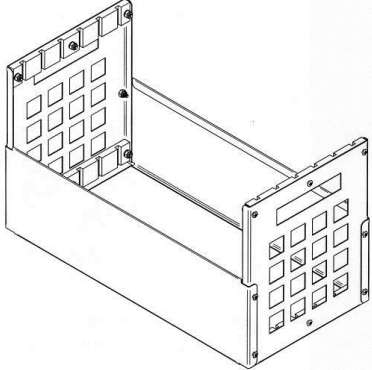
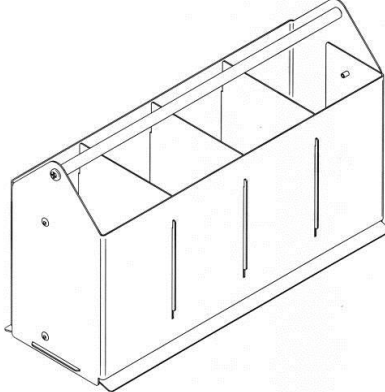
PART #	DESCRIPTION	
4588500	<p>Bottom Rack – Stainless Steel. Included with SteamScrubber.</p>	
4591500	<p>DNA Sequencing Plate Insert. For electrophoresis plates 10.0 x 16.6 inches (25.4 x 42.1 cm). Holds 6 plates.</p>	
4542500	<p>Utensil Holder. For spatulas, spoons, scoops & miscellaneous utensils.</p>	

Appendix A: Glassware Washer Accessories

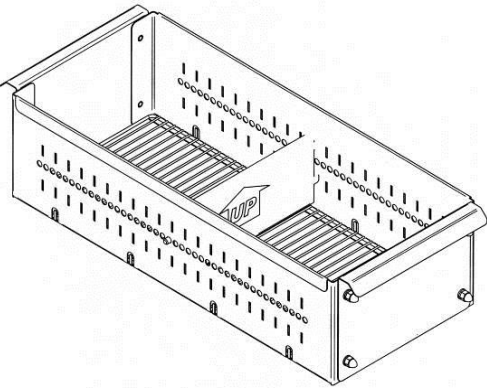
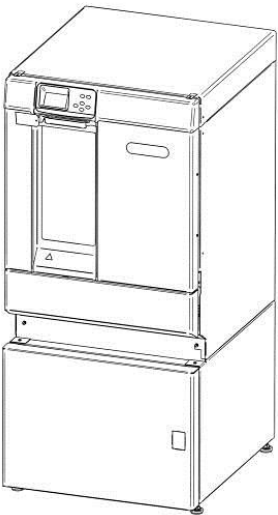
PART #	DESCRIPTION	
4542100	Bulk Tube Insert. For vertically positioning test tubes.	
4595400	Stand. For use with Freestanding models. Raises washer approximately 17 inches (43 cm). Front opens to provide storage underneath washer. Shown with glassware washer installed.	
4591900 (115V) 4591901 (230V)	Cool Drain Water Drain Kit. Provides cool water to the drain plumbing. Connects to a cold water source.	
4587500	Liquid Detergent Dispense Kit. Permits liquid detergent to be dispensed into the glassware washer directly from a 1 gallon container.	
4596100 (115V) 4596101 (230V)	Mobile Conversion Kit. Permits a Freestanding Glassware Washer to be converted to a Mobile model. Includes casters, electrical cord and plug, and plumbing to connect to a sink faucet.	

Appendix A: Glassware Washer Accessories

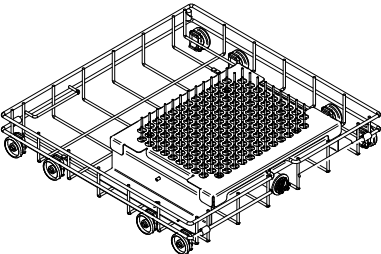
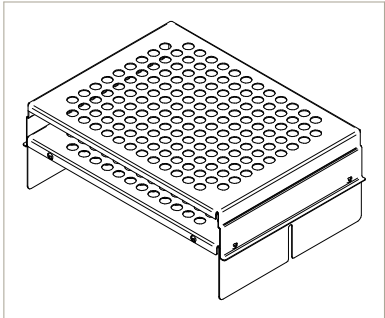
PART #	DESCRIPTION	
4592200	Connection Kit. DI Water inlet valve to plastic tubing.	
1233700	Power Boost Transformer. For 208V operation.	
4546000	Test Tube Spindle Rack. Lower rack with 150 spindles for washing test tubes 10mm to 25mm.	
4546100	10-13mm Test Tube Holder. Holds 150 tubes. Used with Test Tube Spindle Rack	
4546200	14-20mm Test Tube Holder. Holds 75 tubes. Used with Test Tube Spindle Rack	
4526300	10-13mm Test Tube Holder. Holds 75 tubes. Used with Test Tube Spindle Rack	

CONSUMABLES

PART #	DESCRIPTION
4422000	10-lb. (4.5 kg) LabSolutions Powder Detergent
4422100	27.5-lb. (12.5 kg) LabSolutions Powder Detergent
4522000	1 gallon (3.8 L) LabSolutions Liquid Detergent
4522200	1 liter (34 oz.) LabSolutions Neutralizing Acid Rinse

APPENDIX B

GLASSWARE WASHER DIMENSIONS

Freestanding Washer

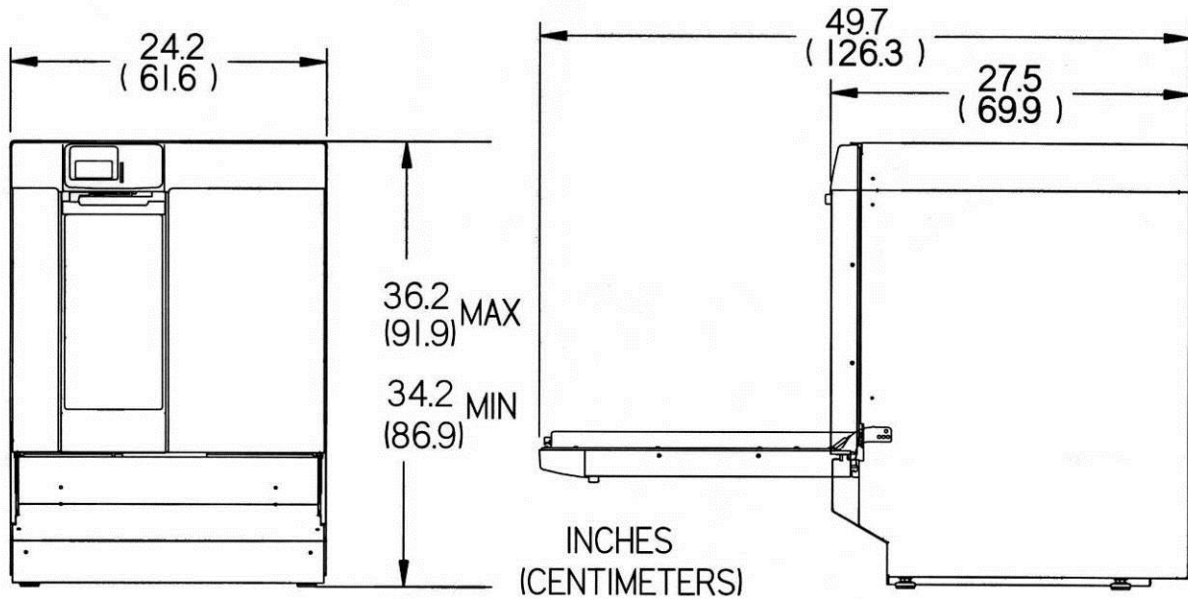

Undercounter Washer

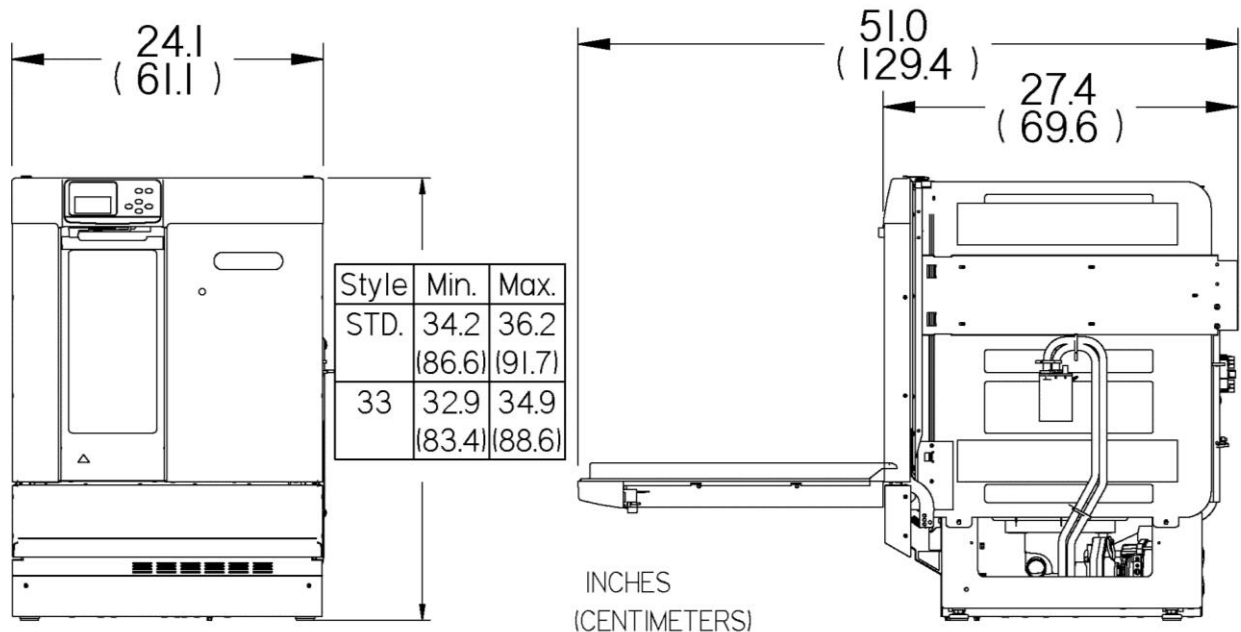

Interior - All SteamScrubbers

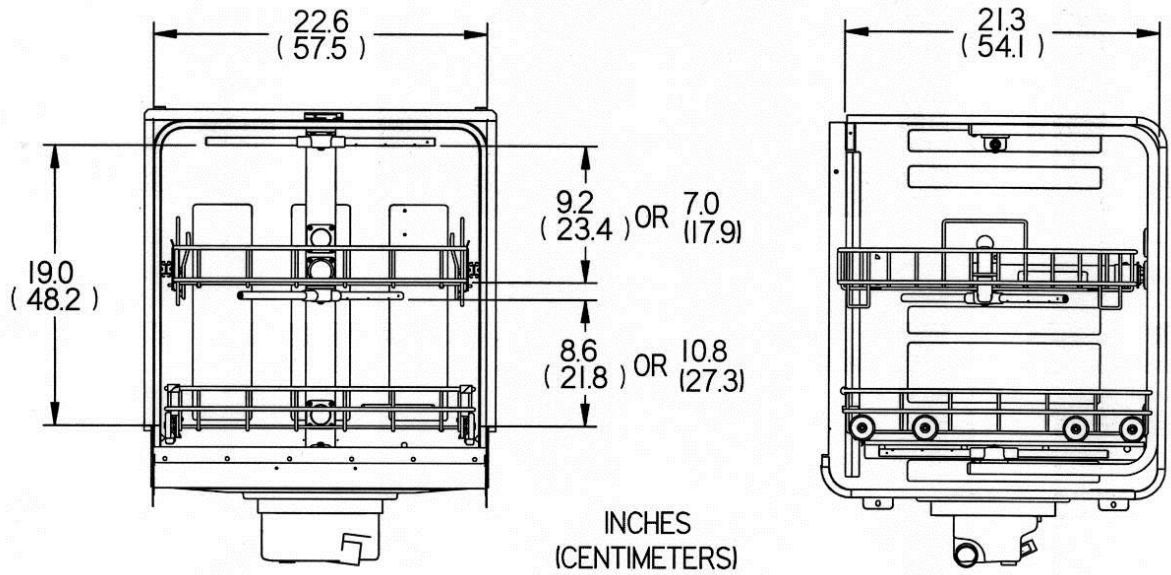

Interior - All FlaskScrubbers

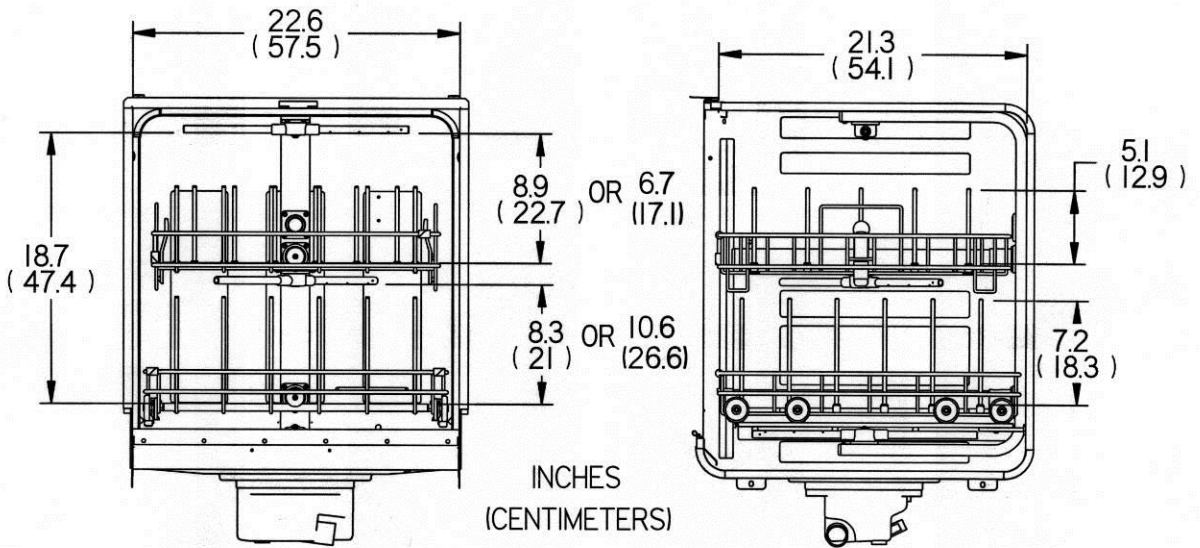

APPENDIX C

GLASSWARE WASHER

SPECIFICATIONS

This Appendix contains various specifications for the Glassware Washer, including program times and water consumption for both the 115V and 230V models.

Glassware Washer Specifications

- Minimum fill water temperature: 120°F (49°C) recommended
- Water consumption per fill: 3.4 gallons (13 liters)
- Minimum feed water pressure: 20 psi (138 kPa)
- Maximum feed water pressure: 120 psi (827 kPa)
- Minimum purified water feed pressure: 0 psi (0 kPa)
- Heat rejected from washer: less than 104 BTU/minute (115V models); less than 170 BTU/minute (230V models)
- Water heating rate: 1.6°F/minute (0.9°C/minute) 115V models operating on 115V; 2.2°F/minute (1.2°C/minute) 230V models operating on 208V

Electrical Specifications

- Operating voltage for 115V washers: 104/127V
- Operating voltage for 230V washers: 207/253V
- Maximum amperage for 115 volt washers: 16.0 amperes
- Maximum amperage for 230 volt washers: 11.0 amperes
- Frequency 115 volt washers: 60 Hz
- Frequency 230 volt washers: 50/60 Hz
- Phase: Single
- Sump element power: 1,200 watts (115V models); 2,000 watts (230V models)

Environmental Conditions

- Indoor use only.
- Maximum altitude: 6562 feet (2000 meters).
- Ambient temperature range: 41° to 104°F (5° to 40°C).
- Maximum relative humidity: 80% for temperatures up to 88°F (31°C), decreasing linearly to 50% relative humidity at 104°F (40°C).
- Main supply voltage fluctuations not to exceed $\pm 10\%$ of the nominal voltage.
- Transient overvoltages according to Installation Categories II (Overvoltage Categories per IEC 1010). Temporary voltage spikes on the AC input line that may be as high as 1500V for 115V models and 2500V for 230V models are allowed.
- Used in an environment of Pollution degrees 2 (i.e., where normally only non-conductive atmospheres are present). Occasionally, however, a temporary conductivity caused by condensation must be expected, in accordance with IEC 664.

Program Times & Water Consumption (115V Models)

Factory Program Descriptions and Possible User Modifications- 115V Models

	Units	Rinse Only		Plastic		Glass		Glass Plus		Science	
		Factory	User set	Factory	User set	Factory	User set	Factory	User set	Factory	User set
Delayed Start	(hours)	0	1 to 8	0	0 to 8	0	0 to 8	0	0 to 8	0	0 to 8
Wash 1 Time	(minutes)			0	None	5	None	5	None	5	None
Steam				No	None	No	Yes / No	Yes	Yes / No	No	Yes / No
Wash 2 Time	(minutes)			10	1 to 40	10	1 to 40	10	1 to 40	20	1 to 40
Wash 2 Temp	(°F) (°C)			122 50	100 to 140 38-60	140 60	100 to 180 38-82	140 60	100 to 180 38-82	158 70	100 to 180 38-82
Number of Rinses		1	0 to 6	2	0 to 6	3	0 to 6	3	0 to 6	4	0 to 6
No of Pure Rinses		0	0 to 6	0	0 to 6	0	0 to 6	0	0 to 6	0	0 to 6
Rinse Time	(minutes)	4	None	4	None	4	None	4	None	4	None
Final Rinse Temp	(°F) (°C)	100 38	100 to 140 38 to 60	122 50	100 to 140 38 to 60	140 60	100 to 180 38 to 82	140 60	100 to 180 38 to 82	140 60	100 to 180 38 to 82
Dry Time	(minutes)	0	0 or 15 to 250	15	0 or 15 to 250	30	0 or 15 to 250	30	0 or 15 to 250	40	0 or 15 to 250
Dry Temp	(°F) (°C)	100 38	100 to 140 38 to 60	122 50	100 to 140 38 to 60	140 60	100 to 158 38 to 70	140 60	100 to 158 38 to 70	140 60	100 to 158 38 to 70
Total Water Consumption	(gallons) (liters)	3.4 12.9	3.4 to 20.4 12.9 to 77.2	13.6 51.5	6.8 to 27.2 25.7 to 103.0	17.0 64.4	6.8 to 27.2 25.7 to 103.0	17.0 64.4	6.8 to 27.2 25.7 to 103.0	20.4 77.2	6.8 to 27.2 25.7 to 103.0
Total Wash Time (Excluding delays for heating water and dry time)	(min)	10		51		86		96		116	

Note
Times shown are for tap water rinses. Pure rinses add 1.5 minutes per rinse.
Additional time is required to allow inlet water to heat up to the set temperature.
Steam adds 10 minutes to the total program time.

Factory Program Descriptions and Possible User Modifications- 115V Models

	Units	Science Plus		Dry Only		User 1		User 2	
		Factory	User set	Factory	User set	Factory	User set	Factory	User set
Delayed Start	(hours)	0	0 to 8	0	0 to 8	0	0 to 8	0	0 to 8
Wash 1 Time	(minutes)	5	None	5	None	5	None	5	0 to 10
Steam		Yes	Yes / No	No	Yes / No	No	Yes / No	No	Yes / No
Wash 2 Time	(minutes)	20	1 to 40	10	1 to 40	10	1 to 40	10	1 to 40
Wash 2 Temp	(°F) (°C)	158 70	100 to 180 38-82	140 60	100 to 180 38-82	140 60	100 to 180 38-82	140 82	100 to 180 38-82
Number of Rinses		4	0 to 6	2	0 to 6	2	0 to 6	2	0 to 6
No of Pure Rinses		0	0 to 6	0	0 to 6	0	0 to 6	0	0 to 6
Rinse Time	(minutes)	4	None	4	None	4	None	4	1 to 30
Final Rinse Temp	(°F) (°C)	140 60	100 to 180 38 to 82	140 60	100 to 180 38 to 82	140 60	100 to 180 38 to 82	140 60	100 to 180 38 to 82
Dry Time	(minutes)	40	0 or 15 to 250	60	0 or 15 to 250	15	0 or 15 to 250	15	0 or 15 to 250
Dry Temp	(°F) (°C)	140 60	100 to 158 38 to 70	140 60	100 to 158 38 to 70	140 60	100 to 158 38 to 70	140 60	100 to 158 38 to 70
Total Water Consumption	(gallons) (liters)	20.4 77.2	6.8 to 27.2 25.7 to 103.0	0 0	0 0	13.6 51.5	6.8 to 27.2 25.7 to 103.0	13.6 51.5	6.8 to 27.2 25.7 to 103.0
Total Wash Time (Excluding delays for heating water and dry time)	(min)	126		60		62		62	

Program Times & Water Consumption (230V Models)

Factory Program Descriptions and Possible User Modifications- 230V Models

	Units	Rinse Only		Plastic		Glass		Glass Plus		Science		Science Plus	
		Factory	User set	Factory	User set	Factory	User set	Factory	User set	Factory	User set	Factory	User set
Delayed Start	(hours)	0	0 to 8	0	0 to 8	0	0 to 8	0	0 to 8	0	0 to 8	0	0 to 8
Wash 1 Time	(minutes)	5	None	5	None	5	None	5	None	5	None	5	None
Steam		No	None	No	Yes/No	Yes	Yes/No	No	Yes/No	Yes	Yes/No	Yes	Yes/No
Wash 2 Time	(minutes)	10	1 to 40	10	1 to 40	10	1 to 40	10	1 to 40	20	1 to 40	20	1 to 40
Wash 2 Temperature	(°F) (°C)	122 50	100 to 140 38 to 60	140 60	100 to 199 38 to 93	140 60	100 to 199 38 to 93	140 60	100 to 199 38 to 93	158 70	100 to 199 38 to 93	158 70	100 to 199 38 to 93
Number of Rinses		1	0 to 6	2	0 to 6	3	0 to 6	3	0 to 6	4	0 to 6	4	0 to 6
No of Pure Rinses		0	0 to 6	0	0 to 6	0	0 to 6	0	0 to 6	0	0 to 6	0	0 to 6
Rinse Time	(minutes)	4	None	4	None	4	None	4	None	4	None	4	None
Final Rinse Temp	(°F) (°C)	100 38	100 to 140 38 to 60	122 50	100 to 140 38 to 60	140 60	100 to 199 38 to 93	140 60	100 to 199 38 to 93	158 70	100 to 199 38 to 93	158 70	100 to 199 38 to 93
Dry Time	(minutes)	0	0 or 15 to 250	15	0 or 15 to 250	30	0 or 15 to 250	30	0 or 15 to 250	40	0 or 15 to 250	40	0 or 15 to 250
Dry Temperature	(°F) (°C)	100 38	100 to 140 38 to 60	122 50	100 to 140 38 to 60	140 60	100 to 158 38 to 70	140 60	100 to 158 38 to 70	140 60	100 to 158 38 to 70	140 60	100 to 158 38 to 70
Total Water Consumption	(gallons) (liters)	3.4 12.9	3.4 to 20.4 12.9 to 77.2	13.6 51.5	6.8 to 27.2 25.7 to 103.0	17.0 64.4	6.8 to 27.2 25.7 to 103.0	17.0 64.4	6.8 to 27.2 25.7 to 103.0	20.4 77.2	6.8 to 27.2 25.7 to 103.0	20.4 77.2	6.8 to 27.2 25.7 to 103.0
Total Wash Time (Excluding delays for heating water and dry time)	(min)	10	51	86	96	116	126						

Note
Times shown are for tap water rinses. Pure rinses add 1.5 minutes per rinse. Additional time is required to allow inlet water to heat up to the set temperature. Steam adds 10 minutes to the total program time.

Factory Program Descriptions and Possible User Modifications- 230V Models

	Units	<u>Intense</u>		<u>Intense Plus</u>		<u>Extreme</u>		<u>Dry Only</u>		<u>User 1</u>		<u>User 2</u>	
		Factory	User set	Factory	User set	Factory	User set	Factory	User set	Factory	User set	Factory	User set
Delayed Start	(hours)	0	0 to 8	0	0 to 8	0	0 to 8	0	0 to 8	0	0 to 8	0	0 to 8
Wash 1 Time	(minutes)	10	None	10	None	10	None	5	None	5	None	5	0 to 10
Steam		No	Yes/No	Yes	Yes/No	Yes	Yes/No	No	Yes/No	No	Yes/No	No	Yes/No
Wash 2 Time	(minutes)	30	1 to 40	30	1 to 40	40	1 to 40	10	1 to 40	10	1 to 40	10	1 to 40
Wash 2 Temperature	(°F)	180	100 to 199	180	100 to 199	199	100 to 199	140	100 to 199	140	100 to 199	180	100 to 199
	(°C)	82	38 to 93	82	38 to 93	93	38 to 93	60	38 to 93	60	38 to 93	82	38 to 93
Number of Rinses		5	0 to 6	5	0 to 6	6	0 to 6	2	0 to 6	2	0 to 6	2	0 to 6
No of Pure Rinses		0	0 to 6	0	0 to 6	0	0 to 6	0	0 to 6	0	0 to 6	0	0 to 6
Rinse Time	(minutes)	4	None	4	None	4	None	4	None	4	None	4	1 to 30
Final Rinse Temp	(°F)	180	100 to 199	180	100 to 199	199	100 to 199	140	100 to 199	140	100 to 199	180	100 to 199
	(°C)	82	38 to 93	82	38 to 93	93	38 to 93	60	38 to 93	60	38 to 93	82	38 to 93
Dry Time	(minutes)	50	0 or 15 to 250	50	0 or 15 to 250	60	0 or 15 to 250	60	0 or 15 to 250	15	0 or 15 to 250	15	0 or 15 to 250
Dry Temperature	(°F)	140	100 to 158	140	100 to 158	140	100 to 158	140	100 to 158	140	100 to 158	140	100 to 158
	(°C)	60	38 to 70	60	38 to 70	60	38 to 70	60	38 to 70	60	38 to 70	60	38 to 70
Total Water Consumption	(gallons)	23.8	6.8 to 27.2	23.8	6.8 to 27.2	27.2	6.8 to 27.2	0	0	13.6	6.8 to 27.2	13.6	6.8 to 27.2
	(liters)	90.1	25.7 to 103.0	90.1	25.7 to 103.0	103.0	25.7 to 103.0	0	0	51.5	25.7 to 103.0	51.5	25.7 to 103.0
Total Wash Time (Excluding delays for heating water and dry time)	(min)	150		160		190		60		62		62	