

20000005206

RV10 bd_072017

IKA®

IKA® RV 10 basic IKA® RV 10 digital



www.imlab.eu

info@imlab.be - Tél. : +32 (0)16 73 55 72

imLab

www.imlab.eu

info@imlab.fr - Tél. : +33 (0)3 20 55 19 11

Imlab sprl - Oude Vijvers, 1
3370 Boutersem - Belgique

Imlab sarl - Centre d'Affaires de l'Horlogerie
48 rue des Canoniers - 59000 Lille - France

Contents

	Page
Declaration of conformity	3
Explication of warning symbols	21
Warranty	21
Safety instructions	22
Correct use	23
Unpacking	24
Useful information	24
Setting up	25
Drive RV 10 basic/ digital	
Heating bath	
Glassware	
Hose system	
Interfaces and outputs	29
Commissioning	30
Maintenance and cleaning	31
Accessories	32
Error codes	34
Technical data	35
Solvent table (excerpt)	35

Explication of warning symbols



General hazard



Danger of being burnt!

Warranty

In accordance with **IKA**[®] warranty conditions, the warranty period is 24 months. For claims under the warranty please contact your local dealer. You may also send the machine direct to our factory, enclosing the delivery invoice and giving reasons for the claim. You will be liable for freight costs.

The warranty does not cover worn out parts, nor does it apply to faults resulting from improper use, insufficient care or maintenance not carried out in accordance with the instructions in this operating manual.

Safety instructions

For your protection



Read the operating instructions in full before starting up and follow the safety instructions.

- Keep the operating instructions in a place where they can be accessed by everyone.
- Ensure that only trained staff work with the appliance.
- Follow the safety instructions, guidelines, occupational health and safety and accident prevention regulations. **When working under a vacuum in particular!**
- Wear your personal protective equipment in accordance with the hazard category of the medium to be processed. Otherwise there is a risk of:
 - splashing liquids,
 - body parts, hair, clothing and jewellery getting caught,
 - injury as a result of glass breakage.
- **Caution!** Inhalation of or contact with media such as poisonous liquids, gases, spray mist, vapours, dusts or biological and microbiological materials can be hazardous to user.
- Set up the device in a spacious area on an even, stable, clean, non-slip, dry and fireproof surface.
- Ensure that there is sufficient space above the device as the glass assembly may exceed the height of the device.
- Prior to each use, always check the device, accessories and especially the glass parts for damage. Do not use damaged components.
- Ensure that the glass assembly is tension-free! Danger of cracking as a result of:
 - stress due to incorrect assembly,
 - external mechanical hazards,
 - local temperature peaks.
- Ensure that the stand does not start to move due to vibrations respectively unbalance.
- Beware of hazards due to:
 - flammable materials,
 - combustible media with a low boiling temperature.



• **Caution!** Only process and heat up media that has a flash point higher than the adjusted safe temperature limit of the heating bath that has been set.

The safe temperature limit of the heating bath must always be set to at least 25 °C lower than the fire point of the media used.

- Do **not** operate the appliance in explosive atmospheres, with hazardous substances or under water.
 - Only process media that will not react dangerously to the extra energy produced through processing. This also applies to any extra energy produced in other ways, e.g. through light irradiation.
 - Tasks with the device must only be performed when operation is monitored.
 - Operation with excess pressure is not permitted (for cooling water pressure see "Technical Data")
 - Do not cover the ventilation slots of the device in order to ensure adequate cooling of the drive.
 - There may be electrostatic discharges between the medium and the drive which could pose a direct danger.
 - The appliance is not suitable for manual operation.
 - Safe operation is only guaranteed with the accessories described in the "Accessories" chapter.
 - Refer to the operating instructions for the HB 10 heating bath.
 - Refer to the operating instructions for the accessories, e.g. vacuum pump.
 - Position the positive pressure outlet of the vacuum pump under a fume hood.
- Use the HB 10.2 cover or the HB 10.1 spray guard.
 - Only use the device under an all side-closed exhaust, or a comparable protective device.
 - Adapt the quantity and the type of distilland to the size of the distillation equipment. The cooler must work properly. Monitor the coolant flow rate at the cooler outlet.
 - The glass equipment must always be ventilated when working under normal pressure (e.g. open outlet at cooler) in order to prevent a pressure build-up.
 - Please note that dangerous concentrations of gases, vapours or particulate matter can escape through the outlet at the cooler. Take appropriate action to avoid this risk, for example, downstream cold traps, gas wash bottles or an effective extraction system.
 - Evacuated glass vessels must not be heated on one side; the evaporating flask must rotate during the heating phase.
 - The glassware is designed for operation under a vacuum of up to 1 mbar. The equipment must be evacuated prior to heating (see chapter „Commissioning“). The equipment must only be aired again after cooling. When carrying out vacuum distillation, uncondensed vapours must be condensed out or safely dissipated. If there is a risk that the distillation residue could disintegrate in the presence of oxygen, only inert gas must be admitted for stress relief
 - **Caution!** Avoid peroxide formation. Organic peroxides can accumulate in distillation and exhaust residues and explode while decomposing! Keep liquids that tend to form organic peroxides away from light, in particular from UV rays and check them prior to distillation and exhaust for the presence of peroxides. Any existing peroxides must be eliminated. Many organic compounds are prone to the formation of peroxides e.g. dekalin, diethyl ether, dioxane, tetrahydrofuran, as well as unsaturated hydrocarbons, such as tetralin, diene, cumene and aldehydes, ketones and solutions of these substances.
 - **Danger of burning!** The heating bath, tempering medium, evaporator piston and glass assembly can become hot during operation and remain so for a long time afterwards! Let the components cool off before continuing work with the device.
 - **ATTENTION!** Avoid delayed boiling! Never heat the evaporating flask in the heating bath without switching on the rotary drive! Sudden foaming or exhaust gases indicate that flask content is beginning to decompose. Switch off heating immediately. Use the lifting mechanism to lift the evaporator piston out of the heating bath. Evacuate the danger zone and warn those in the surrounding area!
 - **Caution!** Never operate the device when the evaporator piston is rotating and the lift is raised. Start at low speed and lower the evaporating flask into the heating bath, increase to desired speed. Otherwise hot tempering medium may be sprayed out!
 - Set the speed of the drive so no tempering medium is sprayed out as a result of the evaporator piston rotating in the heating bath. If necessary reduce the speed.
 - Do not touch rotating parts during operation.
 - Imbalance may result in uncontrolled resonance behaviour of the device or assembly. Glass apparatus may be damaged or destroyed. In the event of unbalance or unusual noises, switch off the appliance immediately or reduce the speed.
 - A vacuum may form inside the glassware in case of power outage.
 - The appliance does not start up again automatically following a cut in the power supply.
 - The device is only disconnected from the power supply network if the device power switch is off or the plug is pulled out. If the device power switch is off or the plug is pulled out.
 - The socket for the mains cord must be easily accessible.

Safety lift

When the device is switched off or the power supply disconnected, the internal safety lift removes the evaporating flask from the heating bath.

When the safety lift is powered off, it is designed for a maximum total weight (glassware and solvent) of 3.1 kg.

Sample calculation of total weight with vertical glassware and a 1 litre flask:

Condenser + receiving flask + evaporating flask + consumables =
1200 g + 400 g + 280 g + 100 g = 1980 g

Maximum solvent load = 3100 g – 1980 g = 1120 g

Due to the design, the safety lift cannot be guaranteed for higher loads!

When using other types of condensers such as dry ice or intensive condensers as well as when using return distillation distributors with slip-on condensers, it may be necessary to reduce the load by the added weight of the glass apparatus.

Thus, prior to distillation, check whether the lift goes up without power when laden with the glassware and distillation material.

The safety lift must be checked daily prior to operation. Use the motor to move the lift to the lowest position and press the "Power" key on the

front plate or the main switch on the back right side of the device using the maximum total weight of 3.1 kg.

➔ The evaporating flask is lifted out of the heating bath.

When using for the first time or after a long period of inactivity, proceed as follows: use the motor to move the lift several times to the top and bottom positions by pressing the lift function keys prior to interrupting the power supply.

Note: Switching off and disconnecting the power supply shows a delay compared to switching off using the "Power" switch on the front panel.

If the safety lift is not working, please contact the **IKA**® Service department.

For the evaporating equipment (evaporating flask plus contents), the maximum permissible weight is 3.0 kg! With larger loads there is the risk of broken glass on the steam pipe!

Ensure that the safety lift has been powered down.

When working with large loads, always use low speeds. Unbalanced loads can result in a broken steam pipe!

For protection of the equipment

- The voltage stated on the type plate must correspond to the mains voltage.
- Socket must be earthed (protective ground contact).
- The appliance may only be opened by experts.

- Removable parts must be refitted to the appliance to prevent the infiltration of foreign objects, liquids etc..
- Protect the appliance and accessories from bumps and impacts.

Correct use

• Use

Together with the accessories recommended by **IKA**®, the device is suitable for:

- quick and gentle distillation of liquids
- evaporation of solutions and suspensions
- crystallisation, synthesis or cleaning of fine chemicals
- drying of powder and granulate material
- recycling of solvents

Mode of operation: Tabletop device

• Range of use

- Laboratories
- Pharmacies
- Schools
- Universities

The safety of the user cannot be guaranteed if the appliance is operated with accessories that are not supplied or recommended by the manufacturer or if the appliance is operated improperly contrary to the manufacturer's specifications or if the appliance or the printed circuit board are modified by third parties.

Unpacking

- **Unpacking**

- Please unpack the device carefully
- In the case of any damage a fact report must be sent immediately (post, rail or forwarder)

- **Delivery scope**

see table

	Drive RV 10 basic	Drive RV 10 digital	Heating bath HB 10	Vertical glassware RV 10.1	Vertical glassware RV 10.10 coated	Diagonal Glassware RV 10.2	Diagonal Glassware RV 10.20 coated	Woulff bottle	Bracket	Cooler locking device, compl.	Ring spanner	Operating instructions
RV 10 basic V	x		x	x				x	x	x	x	x
RV 10 basic VC	x		x		x			x	x	x	x	x
RV 10 basic D	x		x			x		x	x	x	x	x
RV 10 basic DC	x		x				x	x	x	x	x	x
RV 10 digital V		x	x	x				x	x	x	x	x
RV 10 digital VC		x	x		x			x	x	x	x	x
RV 10 digital D		x	x			x		x	x	x	x	x
RV 10 digital DC		x	x				x	x	x	x	x	x

Useful information

Distillation is a thermal separating process for liquid compounds based on substance-specific, pressure-dependent boiling points through evaporation and subsequent condensation.

The boiling point temperature decreases with decreasing external pressure which means that work is usually done under reduced pressure. In this way the heating bath can be maintained at a constant temperature (e.g. 60 °C). Using the vacuum, the boiling point is set with a steam temperature of approx. 40 °C. The cooling water for the condensation cooler should not be warmer than 20 °C (60-40-20 rule).

A chemical resistant membrane pump with a vacuum controller should be used to create the vacuum. The pump is protected from solvent residue by the addition of a Woulff bottle and/or a vacuum separator.

Working with a jet pump to create a vacuum can only be recommended to a limited extent as the solvents may contaminate the environment when using these systems.

Speed, temperature, piston size and system pressure all affect the evaporator air capacity.

The optimum capacity of the flow-through condenser is approx. 60%.

This corresponds to condensation on approx. 2/3 of the cooling coil. With larger capacities there is the risk that the uncondensed solvent vapour will be extracted.

The device is equipped with a piston-operated safety mechanism. The glass apparatus may contain a vacuum following interruption to the power supply; vent the system before switching back on. If the power cuts out, the evaporator piston is automatically lifted out of the heating bath by an integrated gas spring.

CAUTION! The safety lift must be checked daily prior to operation. For more information see the section entitled "Safety Instructions - Safety Lift"!

Setting up

Drive RV 10 basic/digital

Caution! Loosen transportation lock (Fig. 4a)

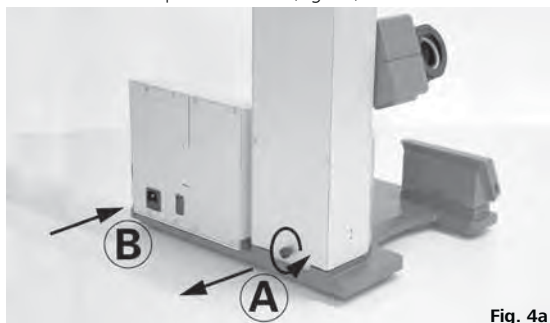

Fig. 4a

- ☞ Hold the lift with your hand and remove the thumb screw on the back of the appliance (A).
- ☞ Once the transportation lock has been removed, the lift moves slowly to its upper end position. The distance is approx. 140 mm.
- ☞ Connect the device to the power supply (B) using the supplied power cord (B).

Adjustable base (Fig. 4b)

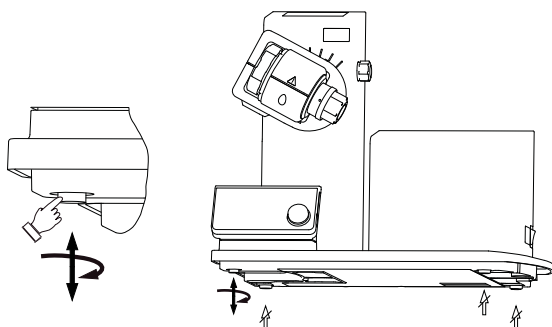

Fig. 4b

Mounting the Woufff bottle (Fig. 5)

- ☞ Fit the hose connecting piece (C) on the left side of the lift.
- ☞ Mount the holder (D) onto the hose connecting piece (C).

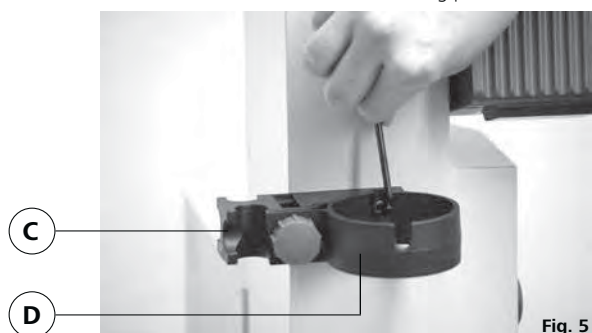

Fig. 5

- ☞ Insert the bottle and attach the supplied hose connectors to the bottle (Fig. 6).



Fig. 6

- ☞ Remove the clamping device for the angle setting of the rotation drive on the right side of the lift by rotating the knurled screw counter clockwise (by lightly pressing and turning at the same time, the knurled screw comes out farther).
- ☞ Set the drive at an angle of approx. 30° (Fig. 7).

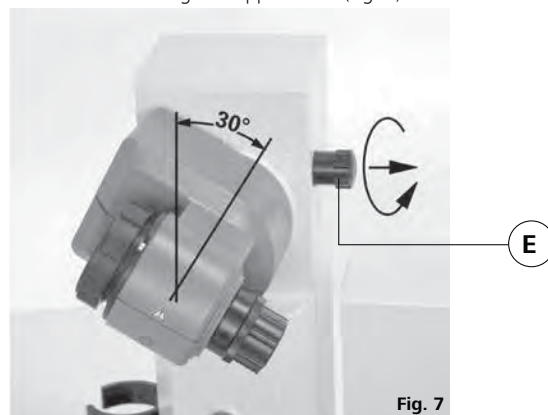

Fig. 7

- ☞ Then secure the rotation drive from being accidentally turned by tightening the knurled screw in a clockwise direction.

Heating bath HB 10

Caution! Refer to the chapter entitled "Commissioning" in the heating bath instruction manual!

- ☞ Place the heating bath on the stand of the rotation drive and push it into the left position (Fig. 8).



Fig. 8

Note: Data is exchanged between the drive unit and the heating bath by means of an infrared link (F). Please note that reliable communication is only guaranteed when the infrared beam has clear line-of-sight to the detector.

Glassware

- ☞ Open the locking device of the steam pipe by turning it 60° counter clockwise (D), (fig. 9).

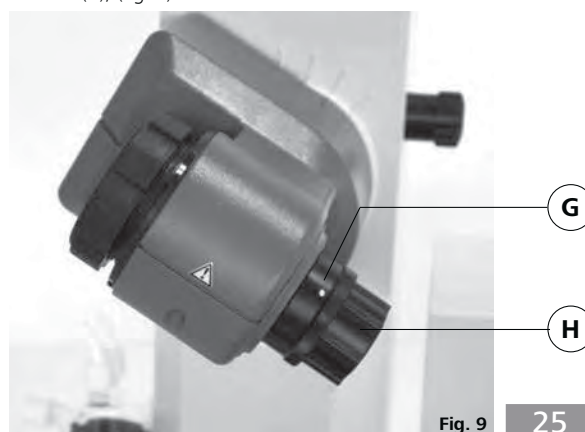

Fig. 9

- ☞ Feed the steam pipe in until it stops.
- ☞ Then lock the locking device by turning it clockwise by 60° (Fig. 10).

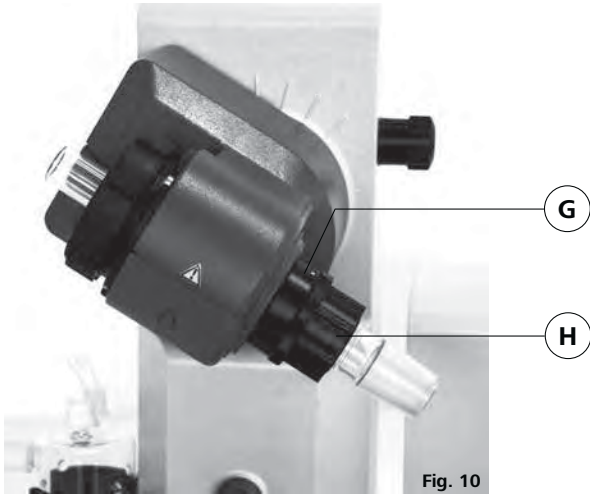

Fig. 10

- ☞ Check the axial locking device on the steam pipe.

Push-off mechanism

The plastic screw nut (H) helps loosen tight-fitting piston ground-in connections (Fig. 10).

- ☞ Hold the locking device (G) and loosen the plastic screw nut (H).
- ☞ To do so, hold the tight-fitting evaporator piston and turn the plastic screw nut (H) until the evaporator piston neck.

Note: Prior to commissioning, hand-tighten the plastic screw nut (H) left-aligned. This will hold the steam pipe locking device (G) firmly in place.

Fitting the condenser seal

- ☞ Place the RV 10.8001 condenser seal in the condenser receptacle and fit the glassware to the device according to the assembly instructions (Fig. 11 a,b, c and d).



Fig. 11a



Fig. 11b

First use - Fitting the seal RV 10.8001

- ☞ Insert vapour tube (1).
- ☞ Insert seal RV 10.8001 (2).
- ☞ Slide the union nut (3b) over the flange on the condenser (3a).
- ☞ Also slide the annular spring (3c) over the flange on the condenser (3a).
- ☞ Position the condenser (3a) on top of the seal (2).
- ☞ Tighten the cap nut hand-screwed (3b).

Note: Follow the mounting instructions for the glassware

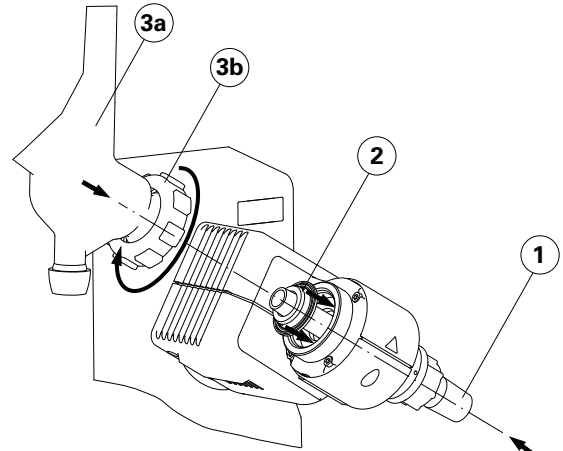

Fig. 11c

Assembling the vertical glassware cooler locking device

- ☞ Assemble the condenser locking device according to the diagram (fig. 12).
- ☞ Mount the plate (I) using the thumb screw (J).
- ☞ Put the support rod (L) on the plate (I) and attach it with the screw nut (K).
- ☞ Attach the rubber protector (M).
- ☞ Fasten the Velcro® band (N) to the support rod (L).
- ☞ Secure the vertical glassware with the Velcro® band (N).

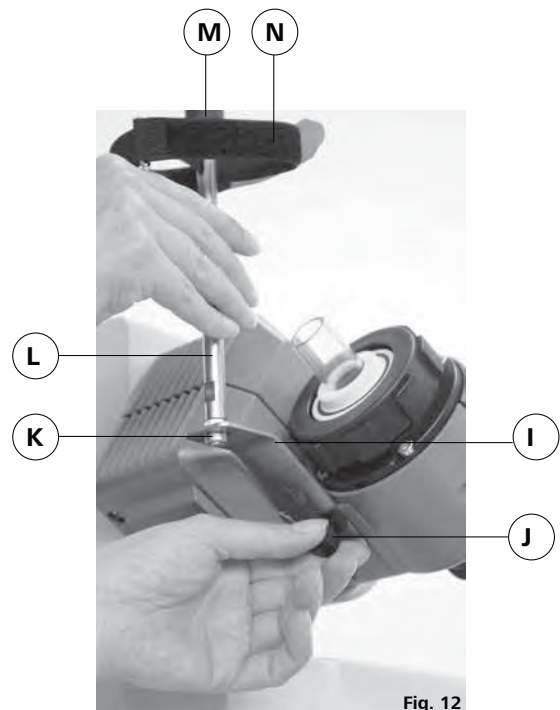
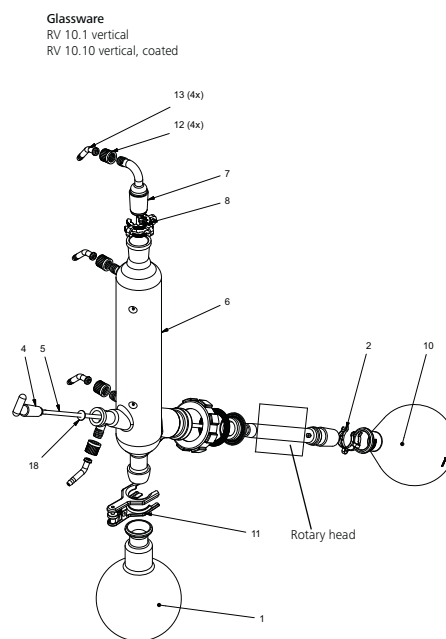
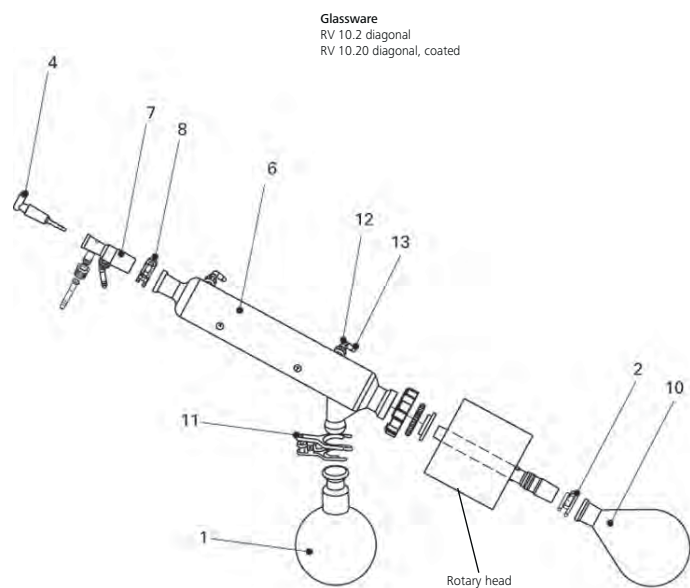

Fig. 12

Mounting the glassware



Item	Designation	Quantity diagonal glassware	Quantity vertical Glassware
1	Receiving flask	1	1
2	Clamp NS 29, stainless steel	1	1
4	Stopcock	1	1
5	Tube	-	1
6	Condenser	1 Diagonal condenser	1 Vertical condenser
7	Connection	1 Introduction sleeve	1 Vacuum connection
8	Clamp NS 29, plastic	1	1
10	Evaporator piston 1000 ml	1	1
11	Ball joint clamp RV 05.10	1	1
12	Screw joint cap	4	4
13	Hose connection	4	4
18	Washer	-	1

Mounting the washer

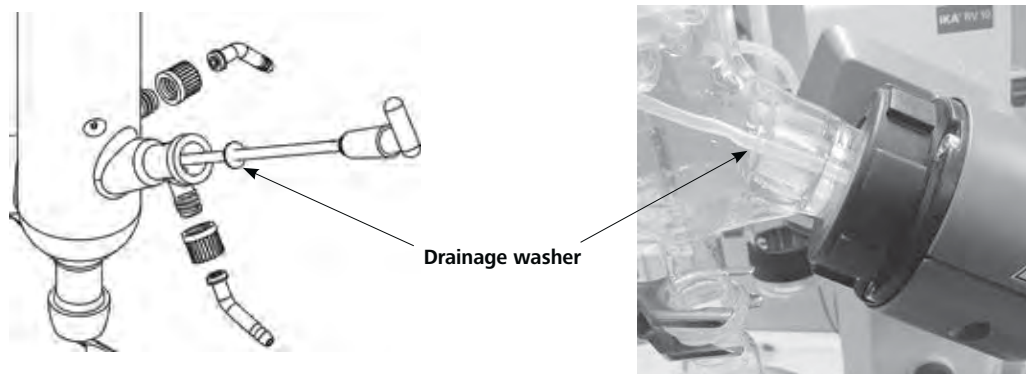

Note: Pay attention to the correct position of the washer.

Removing the condenser

- ☞ Use the ring spanner provided to loosen union nuts that are tightly fitted.
- ☞ Loosen the union nut by turning anticlockwise.
- ☞ Remove the Velcro®.



Description of special condensers

- **RV 10.3 Vertical-intensive condenser with manifold**
This vertical-intensive condenser features a double jacket design for particularly efficient condensation.
Also available with coating (RV 10.30)
- **RV 10.4 Dry ice condenser**
Dry ice condenser for distilling low-boiling solvents.
Cooling by dry ice, no cooling water required. Maximum condensation thanks to low temperatures.
Also available with coating (RV 10.40)
(Cannot be used in automatic mode for the RV10 control)
- **RV 10.5 Vertical-condenser with manifold and cut-off valve for reflux distillation**
Also available with coating (RV 10.50)
- **RV 10.6 Vertical-intensive condenser with manifold and cut-off valve for reflux distillation**
This vertical-intensive action condenser features a double jacket design for particularly efficient reflux distillation.
Also available with coating (RV 10.60)

Hose system

- ☞ Connect the water hoses to the condenser according to the counter-flow principle (Fig. 14).
- ☞ Install the vacuum connections to the condenser, Woulff bottle, vacuum controller with valve and vacuum pump.
- ☞ Always connect the vacuum hose to the condenser at the high-test point to minimise solvent losses during suctioning.
- ☞ Use typical laboratory vacuum hoses with an inside diameter of 8 mm and a wall thickness of 5 mm (see "Accessories").

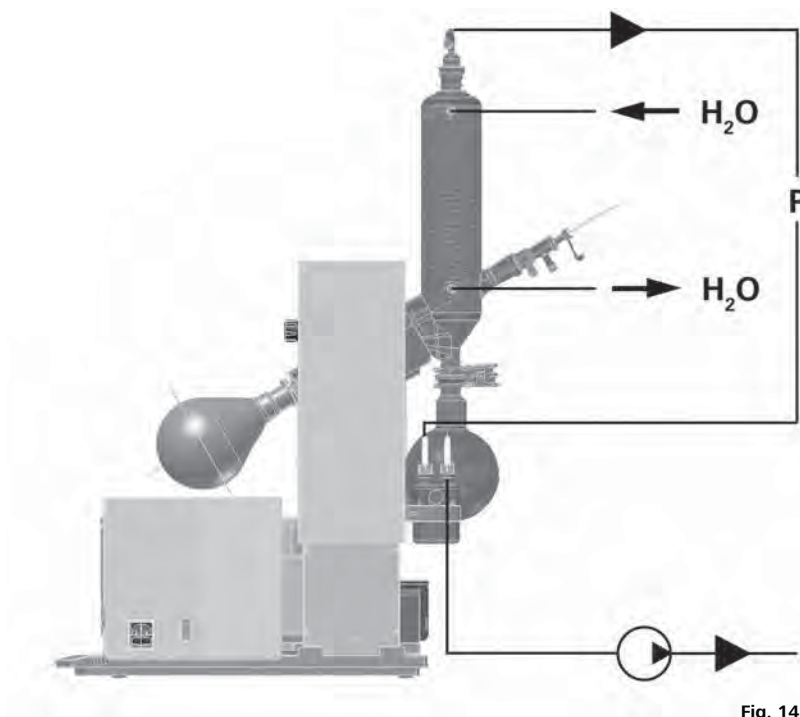

Interfaces and outputs

Data transfer

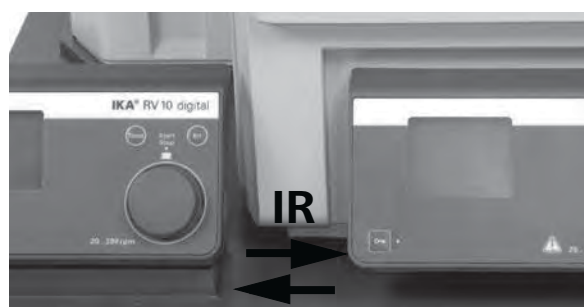

Fig. 15

HB 10

The heating bath transfers data via IR interfaces. These are located on the left display side of the heating bath or on the right side of the drive unit. Do not place any objects between the two operating units as otherwise the data transfer may be interrupted (Fig. 15)!

RV10 digital

The RS 232 interface at the back of the device is fitted with a 9-pole SUB-D jack and can be connected to a PC. The pins have serial signals. Using the laboratory device software "labworldsoft®", the device can be operated in "Remote" mode.

Note: Please note the system requirements as well as the operating instructions and help section included with the software.

Serial interface RS 232 (V24)

Configuration

- The functions of the interface lines between the device and the automation system are a selection from the signals specified in the EIA standard RS232 C, as per DIN 66 020 Part 1.
- For the electrical characteristics of the interface and the allocation of signal status, standard RS 232 C applies in accordance with DIN 66 259 part 1.
- Transmission procedure: asynchronous character transmission in start-stop mode.
- Type of transmission: full duplex.
- Character format: character representation in accordance with data format in DIN 66 022 for start-stop mode. 1 start bit; 7 character bits; 1 parity bit (even); 1 stop bit.
- Transmission speed: 9600 bit/s.
- Data flow control: none
- Access procedure: data transfer from the device to the computer takes place only at the computer's request.

Command syntax and format

The following applies to the command set:

- Commands are generally sent from the computer (Master) to the device (Slave).
- The stirrer machine sends only at the computer's request. Even fault indications cannot be sent spontaneously from the stirrer machine to the computer (automation system).
- Commands are transmitted in capital letters.
- Commands and parameters including successive parameters are separated by at least one space (Code: hex 0x20).

PC 1.1 Cable (Fig. 16)

This cable is required to connect the 9-pin connector to a PC.

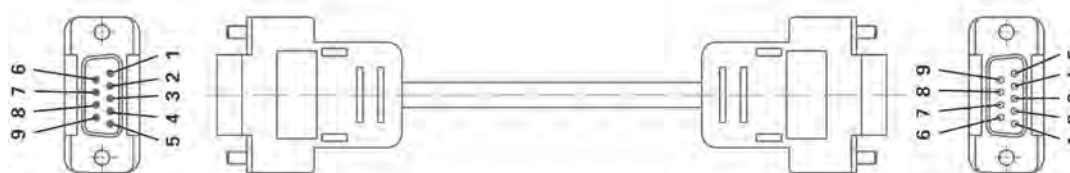

Fig. 16

- Each individual command (incl. parameters and data) and each response are terminated with Blank CR Blank LF (Code: hex 0x20 hex 0x0d hex 0x20 hex 0x0A) and have a maximum length of 80 characters.
- The decimal separator in a number is a dot (Code: hex 0x2E).

The above details correspond as far as possible to the recommendations of the NAMUR working party (NAMUR recommendations for the design of electrical plug connections for analogue and digital signal transmission on individual items of laboratory control equipment, rev. 1.1).

The NAMUR commands and the additional specific IKA® commands serve only as low level commands for communication between the rotary evaporator and the PC. With a suitable terminal or communications programme these commands can be transmitted directly to the rotary evaporator. The IKA® software package, labworldsoft®, provides a convenient tool for controlling rotary evaporator and collecting data under MS Windows, and includes graphical entry features, for motor speed ramps for example.

The following table summarises the (NAMUR) commands understood by the IKA® control equipment.

Abbreviations used:

X,y	=	Numbering parameter (integer)
m	=	Variable value, integer
n	=	Variable value, floating-point number
X	=	4 Speed
X	=	60 Interval time (1-60 seconds, 1 <= m <= 60)
X	=	61 Timer (1-199 minutes, 1 <= m <= 199)
X	=	62 Direction of lift (m=2-> lift up , m=1-> lift down)

NAMUR Commands	Function
IN_NAME	Request designation
IN_PV_X X = 4	Read actual value
IN_SOFTWARE	Request software Id-number, date and version
IN_SP_X X = 4	Read target value input
OUT_SP_X m X = 1,60,61,62	Set target value to m
RESET	Switch to normal operation
START_X X = 4,60,61,62	Switch on appliance (remote) function
STATUS	Status output 0:Manual operation without interruption 1:Automatic operation Start (without interruption) ERROR z (z error number see table)
STOP_X X = 1,60, 61, 62	Switch off appliance function. The variable set with OUT_SP_X remains

Commissioning

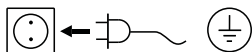

The unit is ready for service when the mains plug has been plugged in.

On/Off switch (Fig. 17)

- ☞ Switch on the device on the right side of the device.
- ☞ Device functions activated.



Fig. 17

Function keys (see page 4)

• "Power" key (1)

- ☞ Press the "Power" key once
- ☞ "Stand-by" mode
- ☞ Press the "Power" key again
- ☞ Device functions reactivated
- ☞ "Software version" display changes to "Parameter" display.

Note: The device must first be switched on at the on/off switch on the right side of the device.

Note: The device is not dead or deenergised until the on/off switch has been switched to off (right side of device)!

• Lift position key "▲" (2)

- ☞ When you press the "▲" key, the lift goes up.
- ☞ When you release the "▲" key, the lift stops and remains in that position.

• Lift position key "▼" (3)

- ☞ When you press the "▼" key, the lift goes down.
- ☞ When you release the "▼" key, the lift stops and remains in that position.

• Rotating knob (4)

Setting the speed

- ☞ Turn the rotating knob
- ☞ Setting the speed
- ☞ Speed setting accuracy: + 5 rpm,
- ☞ Speed range 20-270 rpm

Note: When you select the speed > 100 rpm, smooth start is automatically activated.

Start / Stop Rotation drive

- ☞ Press the rotating knob
- ☞ Rotation drive starts
- ☞ Press the rotating knob again
- ☞ Rotation drive stops

• Timer key (5)

- ☞ Press the "Timer" key.
- ☞ The timer block appears on the display, the "TIMER" indicator flashes.
- ☞ Set the target value "Timer" on the knob by turning (1 to 199 minutes).
- ☞ Save the "Timer" target value by pressing the "Timer" key again.
- ☞ Starting the "Timer" function:
 - Automatic when rotation drive is running
 - Start the rotation drive.

Note: Once the timer has run out, there is a beep, the rotation finishes and the lift goes up.

- ☞ The previously saved value appears on the display.
- ☞ Deactivate the timer by setting the target value to "0".

• Int key (6)

- ☞ Interval cycle for right-left running (change of direction) of the evaporator piston in seconds.
- ☞ Press the "Int" key.
- ☞ The interval block appears on the display, the "INT" indicator flashes.
- ☞ Set the target value "Int" on the knob by turning (1 to 60 minutes).
- ☞ Starting the "Int" function:
 - Automatic when rotation drive is running
 - Start the rotation drive

Note: In interval mode the maximum speed is limited to 200 rpm.

- ☞ Save the "Int" target value by pressing the "Int" key again.
- ☞ Deactivate the interval by setting the target value to "0".

Display (see page 4)

• Display "REMOTE" (10)

(only RV 10 digital)

Remote control via PC in connection with software "labworldsoft®" is active.

• Display "888 rpm" (20)

Current target and actual speed indicator in revolutions per minute [rpm]. When the device is switched on the most recently selected target value "speed" appears.

• Display "O" (30)

Rotation drive active.

• Display "TIMER" (40)

Time lapse control active.

Indication of remaining distillation time in minutes [min].

Note: With the software "labworldsoft®", RV 10 digital can also switch off the heating bath once the timer has run out.

• Display "INT" (50)

Interval mode activated.

• Display "E01" (20)

--- not pictured ---

Error codes, see chapter entitled "Error Codes".

Setting the lower end stop

Caution! Depending on the size of the piston, the setting angle of the rotation drive and the position of the heating bath and lift, the evaporator piston can be in contact with the bottom of the heating bath.

Caution - glass may break!

Limit the lower lift position with the variable end stop.

- ☞ Press the "▼" key until the lift reaches the desired position.

Note: The evaporator piston should be 2/3 immersed in the heating bath.

- ☞ To adjust the stop element (Q), press the centre button (R) on the front of the lift (Fig. 18).
- ☞ Move the stop (Q) to the desired position (Fig. 19)
- ☞ Press the "▲" key until the lift has reached the upper end stop.

Note: The path is limited from 0 – 6 cm.

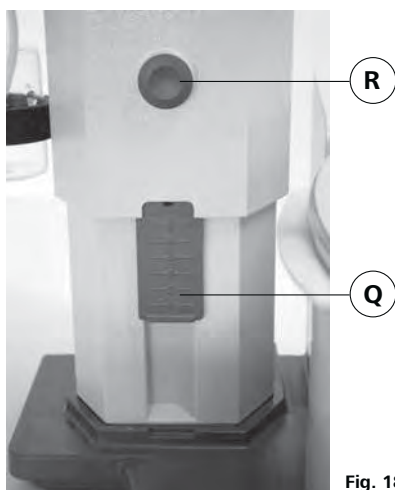

Fig. 18



Fig. 19

Check that the limit stop is functioning properly:

- ☞ Lower the lift by holding down the “▼” key.
- ☞ The drive stops automatically when the preset desired lower end position has been reached.
- ☞ Move the drive back to the upper position.

To activate the safety lift following a long period of inactivity, use the motor to move the lift to the top or bottom position several times prior to starting distillation. (See the section entitled Safety Instructions - Safety Lift!)

Filling the evaporator piston

Prior to filling the evaporator piston, a vacuum controller is used to regulate the glass apparatus to the target pressure.

- ☞ Now fill the evaporator piston using the backfeed line.
- ☞ Due to the vacuum present, the solvent is suctioned into the evaporator piston. This enables you to keep solvent loss due to suctioning to a minimum.

- ☞ You can also fill the evaporator piston manually prior to creating the vacuum. The evaporator piston should not be filled more than half its volume.

Note: **Caution!** The maximum allowed load (evaporator piston and contents) is 3 kg.



Fig. 20

Setting up the heating bath

Refer also to the operating instructions for the heating bath IKA® HB 10!

- ☞ Move the lift to the bottom position and check the position of the heating bath in relation to the evaporator piston. When using larger evaporator pistons (2 or 3 litres) or depending on the angle of the rotation drive, you can move the heating bath 50 mm to the right.
- ☞ Fill the heating bath with the tempering medium until the evaporator piston is surrounded by tempering medium to 2/3 of its volume.
- ☞ Switch on the rotation drive and slowly increase the speed

Note: Avoid creating waves.

- ☞ Switch on the heating bath using the main on/off switch.

Note: Avoid stress on the glass due to different evaporator piston and heating bath temperatures when lowering the evaporator piston into the heating bath!

Note: If non-original accessories are used that are not supplied by IKA®, then it is possible that the 50 mm travel range provided by the heating bath will not be sufficient. This applies in particular when using 3 L evaporator flasks with foam brake.

Use the IKA® RV 10.3000 mounting plate to extend the heating bath travel range by 150 mm.

Maintenance and cleaning

The device is maintenance-free. It is subject only to the natural wear and tear of components and their statistical failure rate.

The seal on the glass condenser should be checked at regular intervals and replaced if necessary.

☞ For cleaning disconnect the main plug.

To clean the device use only water with a detergent that contains tensides, or use isopropylalcohol for stubborn soiling.

Safety lift

The safety lift must be checked daily prior to operation! After a long period of inactivity (approx. four weeks), use the motor to move the lift to the top or bottom position several times prior to starting distillation. (See the section entitled Safety Instructions - Safety Lift!) If the safety lift is not working, please contact the IKA® Service department.

Spare parts order

When ordering spare parts, please give:

- Machine type
- Manufacturing number, see type plate
- Item and designation of the spare part, see www.ika.com, spare parts diagram and spare parts list.



Repair

Please only send devices in for repair that have been cleaned and are free of materials which might present health hazards.

For this, use the "certificate of compliance" form which you can obtain from **IKA®** or can download a version for printing from the **IKA®** website at www.ika.com.

If your appliance requires repair, return it in its original packaging. Storage packaging is not sufficient when sending the device - also use appropriate transport packaging.

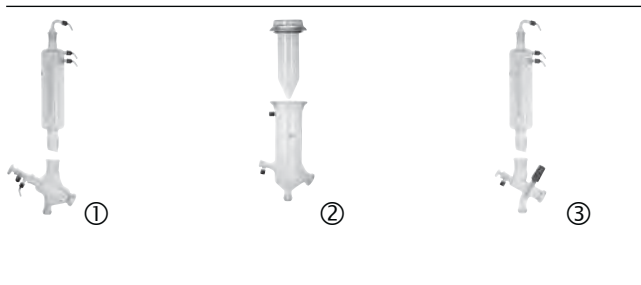
Accessories

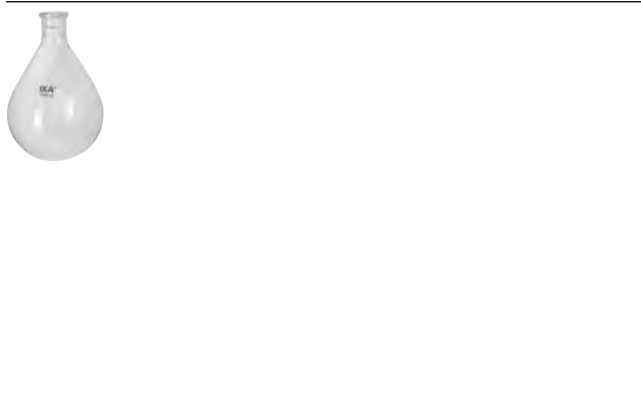
 <p>① ②</p>	<p>RV 10.1 NS 29/32 Vertical glassware (1) RV 10.10 NS 29/32 Vertical glassware, coated (1) RV 10.2 NS 29/32 Diagonal glassware (2) RV 10.20 NS 29/32 Diagonal glassware, coated (2)</p> <p>RV 10.700 NS 29/42 Vertical glassware (1) RV 10.710 NS 29/42 Vertical glassware, coated (1) RV 10.800 NS 29/42 Diagonal glassware (2) RV 10.810 NS 29/42 Diagonal glassware, coated (2)</p> <p>RV 10.900 NS 24/40 Vertical glassware (1) RV 10.910 NS 24/40 Vertical glassware, coated (1) RV 10.1000 NS 24/40 Diagonal glassware (2) RV 10.1010 NS 24/40 Diagonal glassware, coated (2)</p>
 <p>① ② ③</p>	<p>RV 10.3 Vertical-intensive condenser with manifold(1) RV 10.30 Vertical-intensive condenser with manifold, coated (1) RV 10.4 Dry ice condenser (2) RV 10.40 Dry ice condenser, coated (2) RV 10.5 Vertical-condenser with manifold and cut-off valve (no picture) RV 10.50 Vertical-condenser with manifold and cut-off valve, coated (no picture) RV 10.6 Vertical-intensive condenser with manifold and cut-off valve for reflux distillation (3) RV 10.60 Vertical-intensive condenser with manifold and cut-off valve for reflux distillation (3)</p>
 <p>① ②</p>	<p>HB 10.1 Protection shield (Heating bath HB 10) (1) HB 10.2 Protection cover (Heating bath HB 10) (2)</p>
	<p>RV 10.70 NS 29/32 Steam pipe RV 10.71 NS 24/29 Steam pipe RV 10.72 NS 29/42 Steam pipe RV 10.73 NS 24/40 Steam pipe</p> <p>RV 10.74 NS 29/32 Steam pipe, short, for reflux distillation RV 10.75 NS 24/29 Steam pipe, short, for reflux distillation RV 10.76 NS 29/42 Steam pipe, short, for reflux distillation RV 10.77 NS 24/40 Steam pipe, short, for reflux distillation</p>
	<p>RV 10.80 NS 29/32 Evaporator piston 50 ml RV 10.81 NS 29/32 Evaporator piston 100 ml RV 10.82 NS 29/32 Evaporator piston 250 ml RV 10.83 NS 29/32 Evaporator piston 500 ml RV 10.84 NS 29/32 Evaporator piston 1000 ml RV 10.85 NS 29/32 Evaporator piston 2000 ml RV 10.86 NS 29/32 Evaporator piston 3000 ml</p> <p>RV 10.90 NS 24/32 Evaporator piston 50 ml RV 10.91 NS 24/32 Evaporator piston 100 ml RV 10.92 NS 24/32 Evaporator piston 250 ml RV 10.93 NS 24/32 Evaporator piston 500 ml RV 10.94 NS 24/32 Evaporator piston 1000 ml RV 10.95 NS 24/32 Evaporator piston 2000 ml RV 10.96 NS 24/32 Evaporator piston 3000 ml RV 10.97 NS 24/40 Evaporator piston 1000 ml</p>

RV 10.2001	NS 29/42 Evaporator piston	50 ml
RV 10.2002	NS 29/42 Evaporator piston	100 ml
RV 10.2003	NS 29/42 Evaporator piston	250 ml
RV 10.2004	NS 29/42 Evaporator piston	500 ml
RV 10.87	NS 29/42 Evaporator piston	1000 ml
RV 10.2005	NS 29/42 Evaporator piston	2000 ml
RV 10.2006	NS 29/42 Evaporator piston	3000 ml
RV 10.2007	NS 24/40 Evaporator piston	50 ml
RV 10.2008	NS 24/40 Evaporator piston	100 ml
RV 10.2009	NS 24/40 Evaporator piston	250 ml
RV 10.2010	NS 24/40 Evaporator piston	500 ml
RV 10.2011	NS 24/40 Evaporator piston	1000 ml
RV 10.2012	NS 24/40 Evaporator piston	2000 ml
RV 10.2013	NS 24/40 Evaporator piston	3000 ml



RV 10.100	KS 35/20 Receiving flask	100 ml
RV 10.101	KS 35/20 Receiving flask	250 ml
RV 10.102	KS 35/20 Receiving flask	500 ml
RV 10.103	KS 35/20 Receiving flask	1000 ml
RV 10.104	KS 35/20 Receiving flask	2000 ml
RV 10.105	KS 35/20 Receiving flask	3000 ml
RV 10.200	KS 35/20 Receiving flask, coated	100 ml
RV 10.201	KS 35/20 Receiving flask, coated	250 ml
RV 10.202	KS 35/20 Receiving flask, coated	500 ml
RV 10.203	KS 35/20 Receiving flask, coated	1000 ml
RV 10.204	KS 35/20 Receiving flask, coated	2000 ml
RV 10.205	KS 35/20 Receiving flask, coated	3000 ml



RV 10.300	NS 29/32 Powder piston	500 ml
RV 10.301	NS 29/32 Powder piston	1000 ml
RV 10.302	NS 29/32 Powder piston	2000 ml
RV 10.303	NS 24/29 Powder piston	500 ml
RV 10.304	NS 24/29 Powder piston	1000 ml
RV 10.305	NS 24/29 Powder piston	2000 ml
RV 10.2014	NS 29/32 Powder piston	500 ml
RV 10.2015	NS 29/32 Powder piston	1000 ml
RV 10.2016	NS 29/32 Powder piston	2000 ml
RV 10.217	NS 24/40 Powder piston	500 ml
RV 10.218	NS 24/40 Powder piston	1000 ml
RV 10.219	NS 24/40 Powder piston	2000 ml



RV 10.400	NS 29/32 Evaporator cylinder	500 ml
RV 10.401	NS 29/32 Evaporator cylinder	1500 ml
RV 10.402	NS 24/29 Evaporator cylinder	500 ml
RV 10.403	NS 24/29 Evaporator cylinder	1500 ml
RV 10.2020	NS 29/42 Evaporator cylinder	500 ml
RV 10.2021	NS 29/42 Evaporator cylinder	1500 ml
RV 10.2022	NS 24/40 Evaporator cylinder	500 ml
RV 10.2023	NS 24/40 Evaporator cylinder	1500 ml



RV 10.500	NS 29/32 Foam brake	
RV 10.501	NS 24/29 Foam brake	
RV 10.2024	NS 29/42 Foam brake	
RV 10.2025	NS 24/40 Foam brake	



RV 10.600	NS 29/32 Distillation spider with	6 sleeves
RV 10.601	NS 29/32 Distillation spider with	12 sleeves
RV 10.602	NS 29/32 Distillation spider with	20 sleeves
RV 10.603	NS 24/29 Distillation spider with	6 sleeves
RV 10.604	NS 24/29 Distillation spider with	12 sleeves
RV 10.605	NS 24/29 Distillation spider with	20 sleeves
RV 10.2026	NS 29/42 Distillation spider with	6 sleeves
RV 10.2027	NS 29/42 Distillation spider with	12 sleeves
RV 10.2028	NS 29/42 Distillation spider with	20 sleeves

RV 10.2029 NS 24/40 Distillation spider with 6 sleeves
 RV 10.2030 NS 24/40 Distillation spider with 12 sleeves
 RV 10.2031 NS 24/40 Distillation spider with 20 sleeves

RV 10.610 Distilling sleeve 20 ml



RV 10.606 NS 29/32 Distillation spider with 5 flasks 50 ml
 RV 10.607 NS 29/32 Distillation spider with 5 flasks 100 ml

RV 10.608 NS 24/29 Distillation spider with 5 flasks 50 ml
 RV 10.609 NS 24/29 Distillation spider with 5 flasks 100 ml

RV 10.2032 NS 29/42 Distillation spider with 5 flasks 50 ml
 RV 10.2033 NS 29/42 Distillation spider with 5 flasks 100 ml

RV 10.2034 NS 24/40 Distillation spider with 5 flasks 50 ml
 RV 10.2035 NS 24/40 Distillation spider with 5 flasks 100 ml



RV 10.3000 Extension plate



RV 10.8001 Seal, PTFE compound

PC 1.1 Cable
 labworldsoft®

Error codes

Any malfunctions during operation will be identified by an error message on the display (only RV 10 digital).

Once a serious error message has been displayed, the lift moves to the top end position and the device can no longer be operated. The lift can be operated again.

Proceed as follows in such cases:

- ☞ Switch off device using the main switch
- ☞ Carry out corrective measures
- ☞ Restart device

Error code	Effect	Cause	Correction
E01	No or too little rotation	Cable break Load too large Motor blocked	Reduce the volume in the evaporator piston
E02	No communication with the heating bath	Interface hidden or dirty	Check / clean the interface

If the actions described fail to resolve the fault or another error code is displayed then take one of the following steps:

- contact the IKA® service department,
- send the device for repair, including a short description of the fault.

Technical Data

		<i>only RV 10 basic</i>	<i>only RV 10 digital</i>
Operating voltage range	Vac		100 - 230 + 10%
Rated voltage	Vac		100 - 230
Frequency	Hz		50 / 60
Power input without heating bath	W		75
Power input in operation "Stand by"	W		3,3
Speed	rpm		20-280
Speed display			digital
Dimensions of visible display area (W x H)	mm		48 x 35
Display			7 segment display
Multiple languages			-
Right and left movement/ interval operation			yes
Smooth start			yes
Lift			automatically
Lifting speed	mm/s		50
Stroke	mm		140
Setting of lower end stop			60 mm, contactless
Head angle adjustable			0° - 45°
Timer	min		1-199
Interval	sec		1-60
Integrated vacuum controller			-
Interface		-	
Ramp programming		-	
Distillation processes programmable		-	
Remote control		-	
Cooling surface (Standard condenser RV 10.1,10.10,10.2,10.20)	cm ²		1200
Fuse			2xT1, 6A 250V 5x20
Perm. On-time	%		100
Perm. ambient temperature	°C		5-40
Perm. humidity rel.	%		80
Protection acc. to DIN EN 60529			IP 20
Protection class			I
Overvoltage category			II
Contamination level			2
Weight (no glassware; no heating bath)	kg	16,8	
Dimensions (W x D x H)	mm		500 x 410 x 430
Operation at a terrestrial altitude	m		max. 2000 above sea level
			RS 232 with accessory labworldsoft® with accessory labworldsoft® with accessory labworldsoft®
			17,5

Subject to technical changes!

Solvent table (excerpt)

Solvent	Formula	Pressure for boiling point 40 °C in mbar	Solvent	Formula	Pressure for boiling point 40 °C in mbar
Acetic acid	C ₂ H ₄ O ₂	44	Ethylacetate	C ₄ H ₈ O ₂	240
Acetone	C ₃ H ₆ O	556	Ethylmethylketone	C ₄ H ₈ O	243
Acetonitrile	C ₂ H ₃ N	226	Heptane	C ₇ H ₁₆	120
N-Amyl alcohol,	C ₅ H ₁₂ O	11	Hexane	C ₆ H ₁₄	335
n-Pentanol			Isopropyl alcohol	C ₃ H ₈ O	137
n-Butanol	C ₄ H ₁₀ O	25	Isoamyl alcohol,	C ₅ H ₁₂ O	14
tert. Butanol,	C ₄ H ₁₀ O	130	3-Methyl-1-Butanol		
2-Methyl-2-Propanol			Methanol	CH ₄ O	337
Butylacetate	C ₆ H ₁₂ O ₂	39	Pentane	C ₅ H ₁₂	atm.press.
Chlorobenzene	C ₆ H ₅ Cl	36	n-Propyl alcohol	C ₃ H ₈ O	67
Chloroform	C ₁ Cl ₃	474	Pentachloroethane	C ₂ HCl ₅	13
Cyclohexane	C ₆ H ₁₂	235	1,1,2,2-Tetrachloroethane	C ₂ H ₂ Cl ₄	35
Dichloromethane,	CH ₂ Cl ₂	atm.press.	1,1,1-Trichloroethane	C ₂ H ₃ Cl ₃	300
Methylenechloride			Tetrachloroethylene	C ₂ Cl ₄	53
Diethylether	C ₄ H ₁₀ O	atm.press.	Tetrachloromethane	CCl ₄	271
1,2,-Dichloroethylene (trans)	C ₂ H ₂ Cl ₂	751	Tetrahydrofurane (THF)	C ₄ H ₈ O	357
Diisopropylether	C ₆ H ₁₄ O	375	Toluene	C ₇ H ₈	77
Dioxane	C ₄ H ₈ O ₂	107	Trichloroethylene	C ₂ HCl ₃	183
Dimethylformamide (DMF)	C ₃ H ₇ NO	11	Water	H ₂ O	72
Ethanol	C ₂ H ₆ O	175	Xylene	C ₈ H ₁₀	25