

Autosampler A-905

User Manual

Important user information

All users must read this entire manual to fully understand the safe use of Autosampler A-905.

WARNING!



The WARNING! sign highlights instructions that must be followed to avoid personal injury. Do not proceed until all stated conditions are clearly understood and met.

Caution!

The Caution! sign highlights instructions that must be followed to avoid damage to the product or other equipment. Do not proceed until all stated conditions are clearly understood and met.

Note

The Note sign is used to indicate information important for trouble-free and optimal use of the product.

CE certification

This product meets all requirements in applicable CE-directives. A copy of the corresponding Declaration of Conformity is available on request.

The CE symbol and corresponding declaration of conformity, is valid for the kit and instrument when:

- used as a stand-alone unit, or
- connected to other CE-marked Amersham Biosciences instruments, or
- connected to other products recommended or described in this manual, and
- used in the same state as it was delivered from Amersham Biosciences except for alterations described in this manual.

WARNING!

This is a Class A product. In a domestic environment this product might cause radio interference in which case the user might be required to take adequate measures.

Terms and Conditions of Sale

Unless otherwise agreed in writing, all goods and services are sold subject to the terms and conditions of sale of the company within the Amersham Biosciences group which supplies them. A copy of these terms and conditions is available on request.

Should you have any comments on this product, we will be pleased to receive them at:

Amersham Biosciences AB

SE-751 84 Uppsala
Sweden

Trademarks

Drop Design, Ettan, UNICORN and ÄKTA are trademarks of Amersham Biosciences Limited.

Amersham and Amersham Biosciences are trademarks of Amersham plc.

Office Addresses

Amersham Biosciences AB

SE-751 84 Uppsala
Sweden

Amersham Biosciences UK Limited

Amersham Place
Little Chalfont
Buckinghamshire
England HP7 9NA

Amersham Biosciences Corp.

800 Centennial Avenue
P.O. Box 1327
Piscataway, N.J. 08855
USA

Amersham Biosciences Europe GmbH

Munzinger Strasse 9
D-79111 Freiburg
Germany

Amersham Biosciences KK

Sanken Building
3-25-1 Hyakunincho, Shinjuku-ku
Tokyo 169-0073
Japan

www.amershambiosciences.com

© Copyright Amersham Biosciences AB 2003

– All rights reserved

Contents

1 Introduction

1.1 General	7
1.2 Safety	8
1.3 Safety symbols on Autosampler A-905	8

2 Installation

2.1 Unpacking	9
2.2 Locating the A-905	10
2.3 Power connections	11
2.4 UniNet connections	11
2.5 Selecting A-905 in UNICORN	11
2.6 Fluid connections	12
2.7 Preparation of microplates and vials	17

3 Operation

3.1 General	21
3.2 Sample injection techniques	21
3.3 Manual instructions and parameters	24

4 Maintenance

4.1 Injection valve	29
4.2 Needle and tubing	33
4.3 Syringe, sample loop and buffer tubing combinations	34
4.4 Replacing the sample needle	38
4.5 Syringe	39

5 Troubleshooting

5.1 Faults and actions	40
------------------------------	----

6 Reference information

6.1 Description	42
6.2 Technical specifications	51
6.3 Accessories and consumables	53

About this manual

This manual comprises two parts; a practical part (sections 1–5) and a reference part (section 6).

Sections 1–5 contain the necessary information for operating the instrument.

1 Introduction

1.1 General

This manual describes Autosampler A-905 for ÄKTA™ and Autosampler A-905 for Ettan™. They are automated sampling injectors for use in ÄKTA and Ettan liquid chromatography systems.

The autosampler features:

- Sample injection volumes as follows:
 - 1 µl to 1 ml (Autosampler A-905 for ÄKTA).
 - 0.1 µl to 1 ml (Autosampler A-905 for Ettan).
- Three different methods for injection.
- Biocompatibility.
- Different sizes of sample vials.
- Cooling of the sample vials.

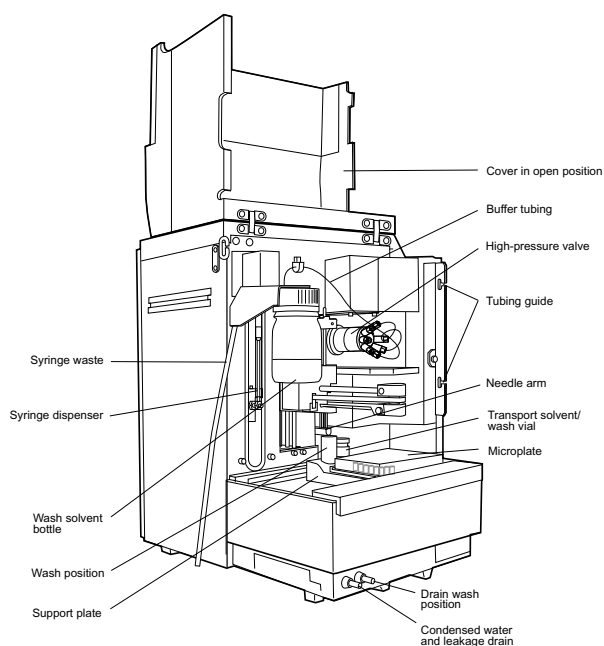

Fig. 1-1. Autosampler A-905

1.2 Safety

- The instrument is designed for indoor use only.
- Do not use in a dusty atmosphere or close to spraying water.
- Do not block the air inlet and outlet of the unit.



WARNING! Always disconnect the power supply before attempting to replace any item on the instrument.



WARNING! Do not operate the Autosampler A-905 with the front cover open.



WARNING! The instrument must not be opened by the user. It contains high voltage circuits that can deliver a lethal electric shock.



WARNING! For continued protection against risk of fire, replace only with fuses of specified type and rating. See technical specifications for fuse data.

1.3 Safety symbols on Autosampler A-905

Autosampler A-905 contains the following safety symbol:



This sticker denotes the proximity of the sharp needle and the moving needle arm of the Autosampler A-905, which, if not handled with care, could result in injury or damage or destruction of these parts.

2 Installation

2.1 Unpacking

Unpack the instrument and check the items against the supplied packing list. Inspect the items for obvious damage that may have occurred during transportation.

Keep all packing materials if onward transport of the instrument is expected.

CAUTION! Do NOT lift the instrument by the front cover!

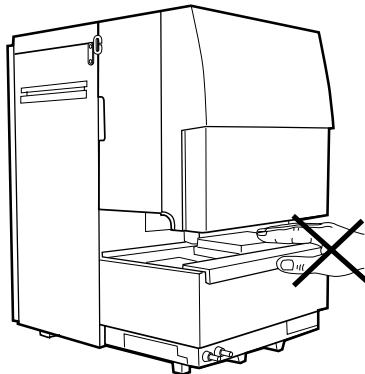

Lift the A-905 with both hands under the instrument or with one hand under the front and the other hand grasping the rear top.

2.2 Locating the A-905

The A-905 needs approximately 28 cm of bench space and a mains connection of 220-240 V or 100-120 V, 50/60 Hz, preferably taken from the system base platform.

Make sure that none of the ventilation holes are blocked. Blockage of the ventilation holes can cause malfunctioning of the A-905 Autosampler or even damage the electronics.

Do not install the A-905 in areas subject to excessive dust, direct sunlight or shocks, and do not place it near a source of heat.

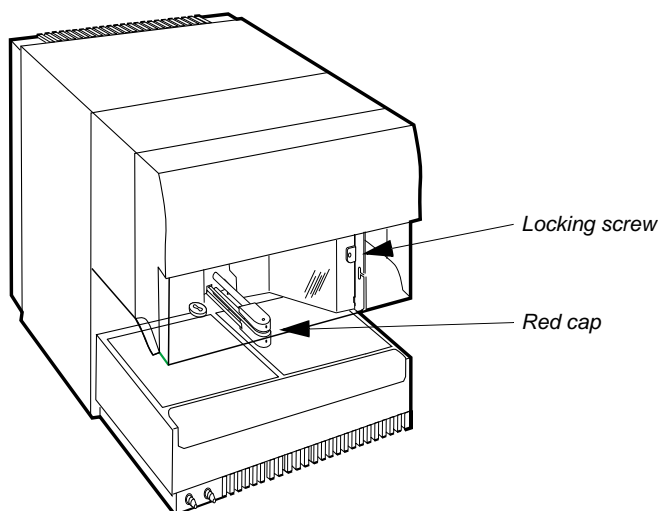

A-905 has two transportation safety devices which must be removed.

- Remove the locking screw holding the front cover. It is located at the right side of the front cover. Save the locking screws.
- A red plastic cap is attached over the needle washing mechanism below the front cover. Remove the plastic cap and save it.

2.3 Power connections

Before connecting the mains cord to your separation unit, check that the voltage setting of the A-905 matches the local mains supply voltage and main fuses. Use only a supply appliance with protective grounding.

If the indicated voltage is not correct, select the proper voltage by removing, inverting, and then re-inserting the voltage selector-cartridge. Check that the right fuses are installed. If not replace them with the fuses stated below:

- For 110-120 V~, use two 5 AT-fuses (slow).
- For 220-240 V~, use two 2.5 AT-fuses (slow).



WARNING! For continued protection against risk of fire, replace only with fuses of specified type and rating. See Technical specifications for fuse data.

When the voltage selection and fuses are correct for your power source, plug in the power cord in a free outlet in the base platform of your separation unit.

2.4 UniNet connections

Autosampler A-905 is controlled from the computer using UniNet cables. The cables are connected to the UniNet-1 ports at the rear of A-905. The cable routing depends on the liquid chromatography system that is used. See the system documentation for detailed instructions on how to connect A-905 to your system.

2.5 Selecting A-905 in UNICORN

After installing the hardware, Autosampler A-905 must be selected in UNICORN™ to make the instructions available.

- 1 Switch on A-905, the system, and the computer. Start UNICORN.
 - 2 In UNICORN Main Menu, select **Administration: System Setup**.
 - 3 Select system and then click **Edit**. Check that the correct strategy is shown in the **Strategy** field.
 - 4 Click **Component**.
 - 5 Select **AutoSampler A-905 (Autosampler in Ettan microLC)** from the list. Click **OK** twice and **Close** to complete the selection of A-905.
-

2.6 Fluid connections

Autosampler A-905 for ÄKTA and Autosampler A-905 for Ettan are factory-installed with different dimensions on some of the fluid handling parts (see Table 2-1).

<i>Fluid handling part</i>	<i>Autosampler A-905 for ÄKTA</i>	<i>Autosampler A-905 for Ettan</i>
Syringe	1 ml	100 µl
Sample needle	15 µl	5 µl
Buffer tubing	2 ml	500 µl
Sample loop	1 ml	20 µl

Table 2-1. Factory-installed fluid handling parts, ÄKTA vs. Ettan

Table 2-2 and Table 2-3 lists the dimensions of all factory-installed tubing in the two autosamplers. A schematic presentation of all parts that have contact with fluid is shown in Figure 2-1.

For optimal performance of the A-905, a correct combination of syringe, loop and buffer tubing should be installed.

To get access to the fluid parts, open the front cover of the A-905.

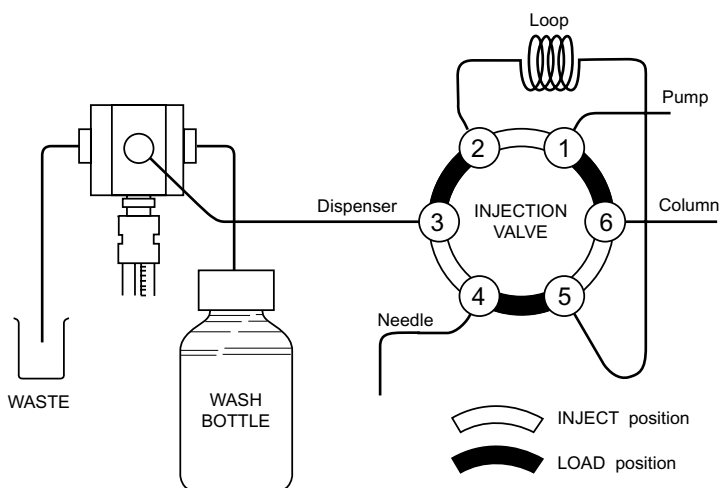

Fig. 2-1. Parts in the flow path

<i>Tubing</i>	<i>Material</i>	<i>Dimensions</i>
Sample needle tubing (Volume: 15 µl)	PEEK	135 mm × o.d. 0.5 mm × i.d. 0.25 mm
Buffer tubing from high pressure valve to syringe valve (Volume: 2 ml)	Teflon	2500 mm × o.d. 1/16" × i.d. 1.0 mm
Tubing, syringe valve to wash solvent bottle	Tefzel	300 mm × o.d. 1/16" × i.d. 1.0 mm
Tubing, syringe valve to waste solvent bottle	Tefzel	400 mm × o.d. 1/16" × i.d. 1.0 mm
1 ml PEEK loop	PEEK	o.d. 1/16" × i.d. 0.5 mm
Tubing, general waste	Silicone	2 x 1.2 m, o.d. 10 mm × i.d. 7 mm

Table 2-2. Factory-installed tubing in Autosampler A-905 for ÄKTA

<i>Tubing</i>	<i>Material</i>	<i>Dimensions</i>
Sample needle capillary (Volume: 5 µl)	Silicate glass	135 mm × i.d. 0.10 mm
Buffer tubing from high pressure valve to syringe valve (Volume: 500 µl)	Teflon	640 mm × o.d. 1/16" × i.d. 1.0 mm
Tubing, syringe valve to wash solvent bottle	Tefzel	300 mm × o.d. 1/16" × i.d. 1.0 mm
Tubing, syringe valve to waste solvent bottle	Tefzel	400 mm × o.d. 1/16" × i.d. 1.0 mm
20 µl PEEK loop	PEEK	o.d. 1/16" × i.d. 0.5 mm
Tubing, general waste	Silicone	2 x 1.2 m, o.d. 10 mm × i.d. 7 mm

Table 2-3. Factory-installed tubing in Autosampler A-905 for Ettan

2.6.1 System connections

To ensure reproducible injections, make the connections to your chromatography system according to the installation instructions, given in the system documentation. Route the tubings through the tubing guide on the right-hand side.

The A-905 has been flushed with 20% isopropanol. Make sure that the mobile phase of your liquid chromatography system is miscible with isopropanol. If not, start with an intermediate solvent as mobile phase (disconnect the column).

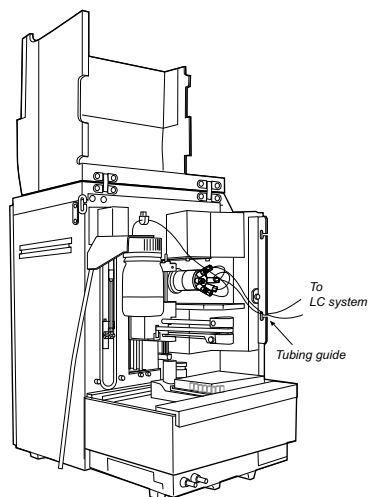

2.6.2 Waste tubing

General waste

Connect the supplied drain tubing to the right-hand drain hose connector of the A-905 and put the other end in a bottle placed on the floor. This drain removes all the liquid dispensed into the wash position.

Note: *Sample that is not injected is also removed through this tubing.*

Syringe waste

Place the syringe waste tubing in a small bottle below the A-905. If injection volumes no larger than the volume of the buffer tubing are programmed, the syringe waste will only be wash solvent.

Leakage drain

All leakage solvents are drained through the left-hand hose connector.

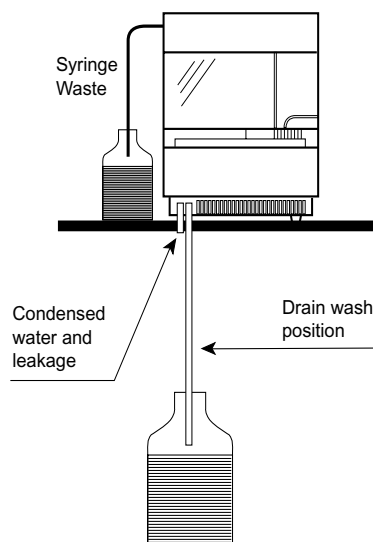

CAUTION! Make sure that the drain and waste tubings are not twisted and obstructing the flow path.

2.6.3 Wash solvent

The A-905 has a built-in wash solvent reservoir of 250 ml (ÄKTA) or 100 ml (Ettan).

To position the wash solvent bottle:

- 1 Fill the wash solvent bottle with 20% ethanol.
- 2 Screw the bottle in the wash solvent holder and place the holder on the A-905.
- 3 Put the wash solvent tubing in the wash solvent bottle.
- 4 Fill the tubing using the `AutosamplerControl_905:SyringeEnd_9051` and `SyringeHome_905` commands in `Manual:Flowpath`.

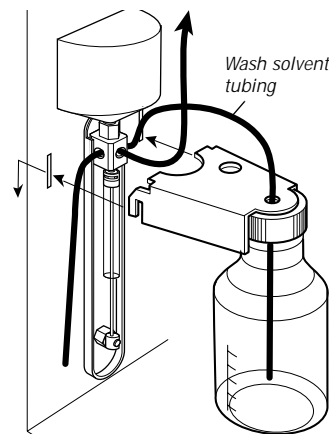

`SyringeEnd_905` aspirates a syringe volume of wash solvent from the wash solvent bottle and fills the wash solvent tubing.

`SyringeHome_905` dispenses the syringe contents to the syringe waste. Repeat this action until the wash solvent tubing and the syringe are completely filled.

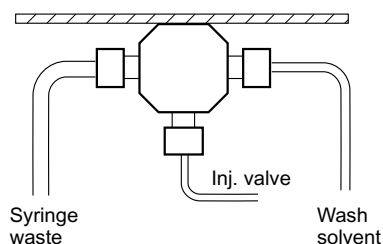

- 5 If there is still air in the syringe, repeat step 4 while gently tapping on the syringe as wash solvent is dispensed to waste. If the air in the syringe persists, see section 4.5 *Syringe*.

¹ The instruction name does not contain “_905” in Autosampler for Ettan.

-
- 6 After the wash solvent tubing and the syringe are filled, use the `AutosamplerControl_905:InitialWash_9051` command in `Manual:Flowpath` to perform a standard wash. All tubing connected to the syringe valve will be filled and flushed with wash solvent.

The wash solvent bottle is now ready for use.

If you have an application that requires more than 100 ml of wash solvent for a complete run, you can replace the wash solvent tubing by a longer tubing with one end flanged for the valve fitting and place a larger bottle outside the A-905. To fill this wash solvent tubing, repeat the previous fill procedure a few times.

¹ The instruction name does not contain “_905” in Autosampler for Ettan.

2.7 Preparation of microplates and vials

Autosampler A-905 is delivered with the following standard type microplates and transport vials:

- 96-well low microplate (1 pc).
- 96-well high microplate (1 pc).
- 384-well low microplate (1 pc).
- 48-vial adapter (1 pc).
- Transport solvent vials, 10 ml

See the table below and Figure 2-2 for detailed information on the plates. Each plate type also has its own logical plate definition in UNICORN.

<i>Plate definition in UNICORN</i>	<i>Plate type</i>	<i>Max. vial diameter</i>
96HIGH	96-well high	7 mm
96LOW	96-well low	7 mm
384LOW	384-well low	—
48VIALS	48-vial adapter	12 mm

2.7.1 Microplate and vial specifications

Dimension of the microplate base:	
Length	127.75 ± 0.25 mm
Width	85.5 ± 0.25 mm
Microplate height, including plate, vial and cap/sealing:	12.5–47.0 mm
Transport solvent vial:	
Width	Max. 22.8 mm
Height	Max. 47.0 mm

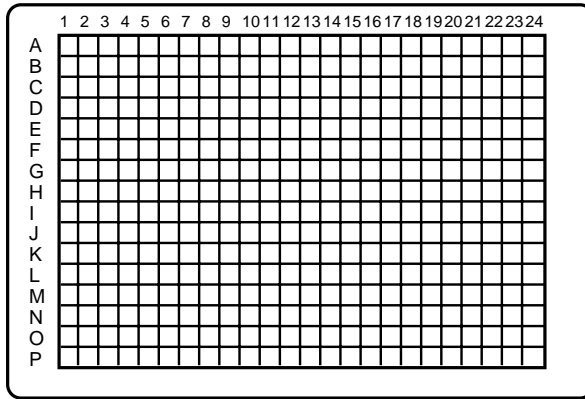

384-well microplate

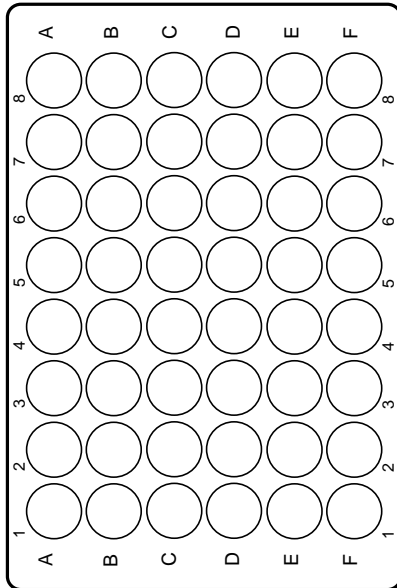

48-vial adapter

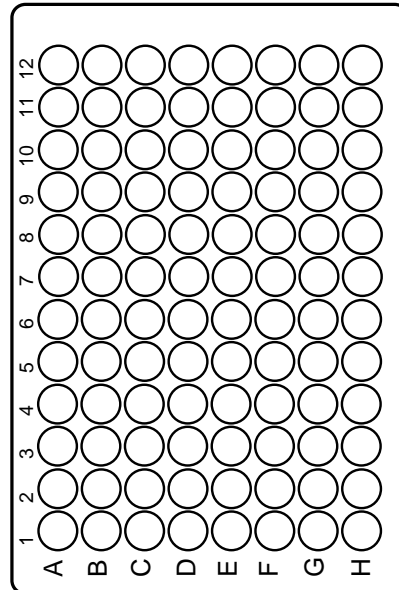
96-well microplate
(High and Low)**Fig. 2-2.** Microplate types for A-905

2.7.2 Recommended microplates and transport vials

The following 96-well microplates are recommended:

Greiner nos., low microplates: 655101, 651101, 650101
Greiner nos., high microplates: 780201
Nunc nos., low microplates: 143761, 168055, 156545, 163320

The following transport vials are recommended:

Chromacol no: 6 CV (6 ml), 10 CV (10 ml)

2.7.3 Filling and sealing wells and vials

The wells, the standard vials, as well as the conical vials, are filled by using a narrow-end pipette to allow air to escape when filling the vial.

CAUTION! Do not fill the wells or the vials to the edge! It will cause sample to enter the gap between the steel needle and the PEEK needle, risking extra cross-contamination of samples and fouling of the needle pair.

If vials are not used, rubber cap mats, self-adhesive aluminum foils and sealing films are available for sealing the wells.

CAUTION! Only use high microplates with the rubber cap mats. If using low microplates, the needle might bend when attempting to penetrate the cap mat.

It is important that the seal is airtight. This maintains a pressure on the vial that prevents air bubbles and stops evaporation of volatile samples.

Note: *Check the seal after crimping or applying the rubber cap mat. If a crimp cap can be turned easily, the seal is not airtight (re-adjust hand crimper). The seal must not be deformed after crimping, since this may also deform the needle.*

The transport solvent vials are sealed by using a standard crimp tool.

2.7.4 Initializing the microplate

The plate type used must be selected in UNICORN.

- 1 In System Control, select System:Settings...
- 2 Select **Specials** in the **Instructions** field, and then **AutosamplerParameters_905:PlateType**¹.

¹ The instruction name does not contain “_905” in Autosampler for Ettan.

3 Operation

3.1 General

Switch on/off A-905 with the mains switch on the rear panel.

A-905 is controlled from a PC running UNICORN version 4.12 or higher. It cannot be used as a stand-alone module. A-905 can be controlled, either automatically from a pre-made method, or manually via instructions.

A-905 can be used for automatic injection of sample solution down to 1 μl (Autosampler A-905 for ÄKTA) or 0.1 μl (Autosampler A-905 for Ettan). To achieve optimal performance, selection of sample loop volume, syringe size and speed, plus the washing method between injections must be considered.



WARNING! Never open the front cover when running A-905. Make sure that A-905 is in idle mode when opening the front cover.

3.2 Sample injection techniques

The sample injection techniques, which can be programmed in the method editor and then used in automatic runs, are as follows:

- **μl pick-up**
The sample is transported into the loop with transport liquid from another vial resulting in virtually no sample loss. μl pick-up results in zero sample loss.
- **Flushed loop**
The sample loop is completely (quantitatively) filled with sample resulting in extremely good reproducibility. The sample loss will be at least 1.6 ml (ÄKTA) or 70 μl (Ettan).
- **Partial loopfill**
The sample loop is partially filled with sample giving low sample loss and allowing programmable injection volumes. The sample loss will be at least 40 μl (ÄKTA) or 10 μl (Ettan).

The corresponding instructions are found by selecting **Manual:Flowpath** in the **System Control** module.

3.2.1 InjectionPickup_905

The InjectionPickup_905¹ instruction selects the µl pick-up injection mode for A-905.

The syringe dispenser aspirates transport liquid from the transport vial into the sample line. The A-905 injection valve is turned to LOAD position. The needle moves from the transport vial to a sample vial and aspirates the selected injection volume. The needle moves back to the transport vial and the sample is quantitatively transported into the sample loop with transport liquid.

Note: *During isocratic runs with RPC and micro-bore columns, we recommend using a transport liquid which has about 20% lower concentration than the B eluent. For example, if the eluent concentration is 60%B, use 48%B in the transport vial. Otherwise, the sample might be flushed straight through the column by the transport liquid without being trapped.*

After each injection, the needle is rinsed:

- If WashExt=NO is selected in the method, the needle is only washed internally.
- If WashExt=YES is selected in the method, the needle is also washed on the outside.

In both cases, the buffering tubing is also washed.

An air segment is not recommended for this injection mode (Air segment=NoAir) because the air segment at the front of the sample plug is injected.

¹ The instruction name does not contain “_905” in Autosampler for Ettan.

3.2.2 InjectionFlushed_905

The **InjectionFlushed_905**¹ instruction selects the flushed loop injection mode for A-905.

The syringe dispenser aspirates a flush volume of sample into the sample line. The A-905 injection valve is turned to LOAD position, and the sample loop is filled with 1.5–3 times the sample loop volume (depending on the loop volume). The injection volume equals the loop volume. When the sample loop size is changed, the loop volume setting must be changed in **System:Settings**.

After each injection, the needle is rinsed:

- If **WashExt=NO** is selected in the method, the needle is only washed internally.
- If **WashExt=YES** is selected in the method, the needle is also washed on the outside.

In both cases, the buffer tubing is also washed.

An air segment (**Air segment=Air**) is recommended to reduce the amount of the flush volume. The air segment is not injected.

3.2.3 InjectionPartial_905

The **InjectionPartial_905**¹ instruction selects the partial loopfill injection mode.

The syringe dispenser aspirates a flush volume of sample into the sample line. The A-905 injection valve is turned to LOAD position, and the sample loop is filled by transporting the selected injection volume into the sample loop, which is partially filled with sample.

After each injection, the needle is rinsed:

- If **WashExt=NO** is selected in the method, the needle is only washed internally.
- If **WashExt=YES** is selected in the method, the needle is also washed on the outside.

In both cases, the buffer tubing is also washed.

An air segment (**Air segment=Air**) is recommended to reduce the amount of the flush volume. The air segment is not injected.

¹ The instruction name does not contain “_905” in Autosampler for Ettan.

3.3 Manual instructions and parameters

3.3.1 AutosamplerControl_905

This instruction contains manual commands used for setting up and maintaining Autosampler A-905. The available commands are:

- InitialWash_905
- SyringeHome_905/SyringeEnd_905
- PlateHome_905/PlateExchange_905
- NeedleHome_905/NeedleFront_905

The commands are found by selecting **Manual:Flowpath** in the **System Control** module, and clicking **AutosamplerControl_905**¹.

InitialWash_905

The **InitialWash_905**¹ command performs a complete wash of the needle and the syringe.

The syringe is first washed using one syringe volume.

Then the needle is moved to its home position and washed internally.

Finally, the needle moves to its front position and is washed both internally and externally.

SyringeHome_905/SyringeEnd_905

The **SyringeHome_905**¹/**SyringeEnd_905**¹ commands are used when the syringe is replaced. They are also used for purging the syringe, i.e. to remove air.

SyringeHome_905 empties the syringe contents to the syringe waste container.

SyringeEnd_905 draws wash solvent into the syringe from the wash bottle.

Note: *When the action is completed, make sure the syringe is run to the Home position before leaving the manual function.*

¹ The instruction name does not contain “_905” in Autosampler for Ettan.

PlateHome_905/EPlateExchange_905

The PlateHome_905¹/PlateExchange_905¹ commands are used when the plate is replaced.

PlateHome_905 moves the plate to its normal position.

PlateExchange_905 moves the plate to the leftmost position.

NeedleHome_905/NeedleFront_905

The NeedleHome_905¹/NeedleFront_905¹ commands are used when the sample needle is replaced.

NeedleHome_905 moves the needle to its normal position.

NeedleFront_905 moves the needle to the front of A-905.

3.3.2 AutosamplerSyringeSpeed_905

The AutosamplerSyringeSpeed_905¹ instruction is used to pre-set the speed of the syringe. The syringe speed needs adjustment when changing syringe size, using highly viscous samples, or using volatile eluents.

Three different speed settings are available:

- Low
- Normal
- High

The actual speed is dependent on the speed setting and a scaling factor, and on the syringe volume. The scaling factor range of 0.1 – 1.0 is used to reduce the basic speed setting.

<i>Syringe volume</i>	<i>Viscosity</i>	<i>Speed setting</i>	<i>Scaling factor</i>
1000 µl	Normal	Low	0.7
250 µl	High (5 - 10 cP)	Low	0.2

Note: *If the sample is viscous, the flush volume can be enlarged and the syringe speed reduced to enhance performance.*

The instruction is found by selecting System:Settings in the System Control module, and then Specials:AutosamplerSyringeSpeed_905¹.

¹ The instruction name does not contain “_905” in Autosampler for Ettan.

3.3.3 AutosamplerParameters_905

This instruction contains hardware related parameters for A-905.

<i>Parameter</i>	<i>Value</i>	<i>Comment</i>
LoopVol	5-1000 µl 1 ml (ÄKTA) and 20 µl (Ettan) are default	Sample loop volume
SyringeVol	100, 250, 500 or 1000 µl 1 ml (ÄKTA) and 100 µl (Ettan) are default	Syringe volume
FlushVol	10-100 µl 40 µl (ÄKTA) and 10 µl (Ettan) are default	Flush volume. The amount of sample, or transport liquid, taken from a vial before the loop is filled with sample.
WashVolume	300-9999 l 1200 µl (ÄKTA) and 300 µl (Ettan) are default	Wash µvolume. Sets the volume for the external wash (WashExt) programmable in the different injection modes.
PlateType	96LOW (default), 96HIGH, 384LOW, 48VIALS	Microplate type.
HeadPress	No, Yes (No is default)	Head-space pressure. Applied via the outer air needle. Assures that no air or vapour bubbles are formed during sample aspiration.
NeedleVol	5, 15 µl 15 µl (ÄKTA) and 5 µl (Ettan) are default	Needle volume. Selects the volume of the needle used.
NeedleHgt	0-40 mm (5 mm is default)	Needle height. A relative measure used to adjust the distance between the tip of the needle and the bottom of the vial used.

Table 3-1. Hardware related parameters for Autosampler A-905

The parameters are found by selecting **System:Settings** in the **System Control** module, and then **Specials:AutosamplerParameters_905**¹.

¹ The instruction name does not contain “_905” in Autosampler for Ettan.

3.3.4 AutoSampler_Temperature_905

The `AutoSampler_Temperature_905`¹ instruction is used to enable the cooling function and to set the desired temperature.

The cooling function is enabled by selecting the **Enabled** check button.

The cooling capacity is maximum 12 °C below the ambient temperature (T) when $16\text{ °C} < T < 40\text{ °C}$.

The cooling starts immediately when clicking on **OK**.

***Note:** The cooling of the sample will be delayed compared to the temperature reading of the cooling block. Check the sample temperature with an external thermometer if necessary.*

The instruction is found by selecting **System:Settings** in the **System Control** module, and then **Specials:AutoSampler_Temperature_905**¹.

3.3.5 Alarm_AutoSampler_905

The `Alarm_AutoSampler_905`¹ instruction is used to set alarm temperatures when using the cooling function. When the alarm is triggered, the system is set to **Pause**.

The alarm function is enabled by selecting the **Enabled** check button.

The upper alarm level is set by the parameter **HighAlarm**, and the lower alarm level by **LowAlarm**.

The instruction is found by selecting **System:Settings** in the **System Control** module, and then **Alarms:Alarm_AutoSampler_905**¹.

3.3.6 Warning_AutoSampler_905

The `Warning_AutoSampler_905`¹ instruction is used to set warning temperatures when using the cooling function. When the warning is triggered, a message will be displayed but the system will not be set to **Pause**.

The warning function is enabled by selecting the **Enabled** check button.

The upper alarm level is set by the parameter **HighWarn**, and the lower alarm level by **LowWarn**.

The instruction is found by selecting **System:Settings** in the **System Control** module, and then **Alarms:Warning_AutoSampler_905**¹.

¹ The instruction name does not contain “_905” in Autosampler for Ettan.

3.3.7 QuantitationData_905

The `Quantitation_Data_9051` instruction is used to send parameters to the evaluation module when creating or updating the quantitation table.

Different levels of standards are used for creating and updating the quantitation table. `Sample` is used for quantification of the sample.

The instruction is found by selecting **View:Text Instructions** in the **Method Editor** module. Select **Flowpath** in the **Instructions** field.

4 Maintenance

4.1 Injection valve

4.1.1 Description

The injection valve is a two position, six-port valve. The figure shows the flow diagram of the valve.

The six small circles represent the ports in the rotor seal. Rotating the valve 60° switches the valve from one position to another.

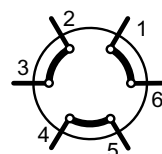

Shaft assembly rotated clockwise

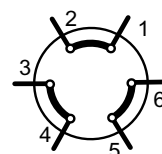

Shaft assembly rotated counterclockwise

4.1.2 Specifications

- Maximum temperature is +50 °C.
- The valve withstands 34.5 MPa (5000 psi).
- Wetted surfaces are made of PEEK, aluminum ceramic, and an inert polymer.



WARNING! Do not operate the A-905 with the front cover open.

CAUTION! Use only plastic ferrules in the PEEK stator ports. Metal ferrules can cause irreparable damage to the plastic stator.

4.1.3 Maintenance (Autosampler A-905 for ÄKTA)

With normal use, the valve will give many tens of thousands of cycles of trouble-free operation. The main cause of early failure, which is seen as a leak in the valve, is abrasive particles in the sample and/or mobile phase scratching the rotor seal.

The procedure for replacing the rotor seal, stator face assembly, and isolation seal is as follows. Refer to the figure and proceed:

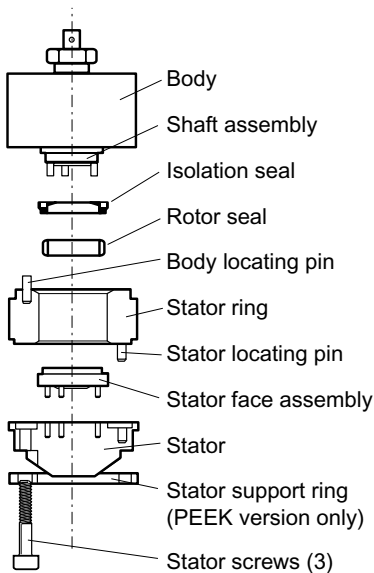

- 1 Remove the three stator screws with a 9/64" hex wrench.
- 2 Remove the stator, stator face assembly and stator ring from the valve body.
- 3 Pull the rotor seal off the pins.
- 4 Remove the isolation seal.
- 5 Mount the new isolation seal with the spring side facing away from the rotor seal.
- 6 Mount the new rotor seal. The three pins on the shaft assembly fit into the mating holes in the rotor seal only one way. Mount the seal with the grooves facing the stator.
- 7 Replace the stator ring so that the body locating pin in the stator ring enters the mating hole in the body.
- 8 Put the new stator face assembly on the stator. The three pins on the assembly fit the mating holes in the stator only one way.
- 9 Mount the stator and stator face assembly on the valve so the stator locating pin in the stator ring enters the mating hole in the stator.
- 10 Replace the three stator screws. Tighten each an equal amount until the screws are tight.

4.1.4 Maintenance (Autosampler A-905 for Ettan)

With normal use, the valve will give many tens of thousands of cycles of trouble-free operation. The main cause of early failure, which is seen as a leak in the valve, is abrasive particles in the sample and/or mobile phase scratching the rotor surface.

Perform the following steps to clean and/or replace the rotor. Refer to the figure and proceed.

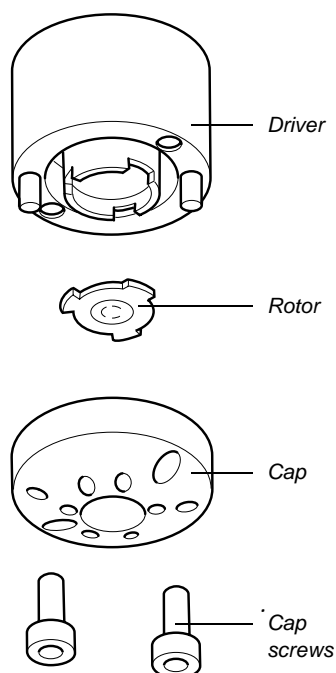

Disassembly

- 1 Use a 9/16" hex driver to remove the cap screws, which secure the cap on the valve.
- 2 To make sure that the sealing surface of the cap is not damaged, rest it on the outer face. Or, if the tubing is still connected, leave it suspended by the tubing.
- 3 Using your fingers or a small tool, gently pry the rotor off the driver.
- 4 Examine the rotor sealing surface for scratches. If there are obvious scratches, the rotor must be replaced. If no scratches are visible, clean all the parts thoroughly with an appropriate solvent. Take care not to scratch the surface. (The most common problem in liquid chromatography is the formation of buffer crystals, which are usually water-soluble.) It is not necessary to dry the rotor.

Reassembly

- 1 Replace the rotor in the driver, making sure that the rotor seal surface with its engraved flow passages is facing out. The pattern is asymmetrical to prevent improper placement.
- 2 Replace the cap. Insert the two cap screws and tighten them gently until both are snug. **Do not over-tighten them** – the screws simply hold the assembly together and do not affect sealing force. The sealing force is automatically set as the screws close the cap against the valve body.
- 3 Test the valve by pressurizing the system. If the valve does not hold pressure, the valve must be replaced.

4.1.5 Operating suggestions

CAUTION! Never operate the injection valve when it is dry. This will reduce the lifetime of the injection valve and probably cause malfunction.

CAUTION! Never leave the A-905 for more than one day with buffer solution in the tubings. Rinse the A-905 with distilled water prior to long stops, and fill the tubing with 20% ethanol.

Aqueous buffers or salt solutions

Prevent the formation of salt crystals in the valve by flushing out the flow passages and needle port with water after using salt solutions. Formation of salt crystals may otherwise damage the injection valve.

Calibrating sample loops

Sample loop sizes are designated by nominal values that can vary from the actual value by as much as 20%. This variation is due to the tolerance of the tubing i.d. Since standards and unknowns are usually analysed with the same loop, knowledge of absolute loop volume is rarely needed. If the actual loop volume must be known, calibrate it in place on the valve, so that the flow passages in the valve (one in the rotor, two in the stator) are also taken into account.

The following PEEK sample loops for the injection valve are available from the valve manufacturer (Rheodyne):

<i>Loop [μl]</i>	<i>Inner diameter</i>	<i>Outer diameter</i>	<i>Manufacturers catalog no.</i>
6	0.007"	1/16"	9055-020
10	0.010"	1/16"	9055-021
20	0.010"	1/16"	9055-022
50	0.020"	1/16"	9055-023
100	0.020"	1/16"	9055-024
200	0.020"	1/16"	9055-025
500	0.030"	1/16"	9055-026
1000	0.030"	1/16"	9055-027

4.2 Needle and tubing

The A-905 has separate needles for puncturing and sampling; the air needle, which punctures the septum of the vial and provides the headspace pressure in the vial, and the sample needle for transporting the sample from the vial into the loop of the valve.

The sample needle enters a vial as follows:

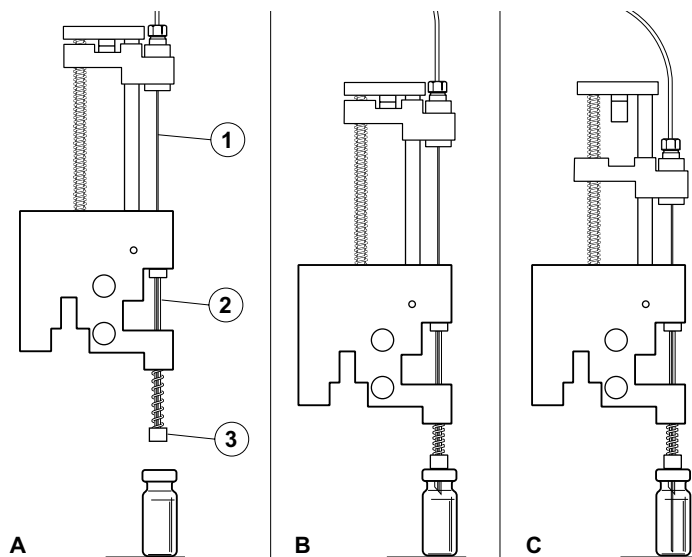

Fig. 4-1. Sample needle entering a vial

- A Initial position.
- B First the air/prepuncturing steel needle (Fig. A, 2) is lowered by moving the complete needle arm downwards. The vial sensor strip (Fig. A, 3) detects if there is a vial and at the same time measures the vial height. If no vial is detected, the needle arm is moved upwards and the A-905 will stop. When the A-905 detects a vial, the lowering speed of the arm is decreased to provide just enough force to puncture the septum of the vial. After forcing the air/prepuncturing needle into the vial, air is applied to the vial. An air outlet nut reduces the pressure in the vial to approximately 0.5 bar.
- C Finally the sample needle (Fig. A, 1) is lowered into the vial to the height programmed in **System:Settings**. Now the A-905 is ready for the first injection.

4.3 Syringe, sample loop and buffer tubing combinations

Four sizes of dispenser syringes are available: 100, 250, 500 and 1000 µl.

4.3.1 Injection volumes

Table 4-1 shows the injection volume ranges that are available for the the different injection modes.

<i>Injection mode</i>	<i>Autosampler A-905 for ÄKTA (1 ml syringe 1 ml sample loop)</i>	<i>Autosampler A-905 for Ettan (100 µl syringe 20 µl sample loop)</i>
Flushed loop	1000 µl	20 µl
Partial loopfill	1–500 µl	0.1–10 µl
µl pick-up	1–478 µl	0.1–2.5 µl

Table 4-1. Injection volume ranges

The maximum injection volumes are calculated as follows:

- Flushed loop: Max. injection volume = loop volume
- Partial loopfill: Max. injection volume = 50% of loop volume
- µl pick-up: Max. injection volume = (loop volume - (3 × needle volume)) / 2

4.3.2 Sample volumes

The sample volume requirements are calculated as follows:

- Partial loopfill¹: Injection volume + flush volume (using tapered or standard vial)
- µl pick-up¹: Injection volume (using tapered or standard vial)
- Flushed loop¹:
 - loop volume < 100 µl: Min. 3 × loop volume + flush volume
 - loop volume 100–499 µl: Min. 2 × loop volume + flush volume
 - loop volume 500–1000 µl: Min. 1.5 × loop volume + flush volume

¹ The first injection from a vial requires additional sample volume. A tapered vial needs 4 µl extra volume and a standard vial needs 300 µl. These volumes must be added to the sample volumes given above.

4.3.3 Flush volumes

The recommended minimum flush volumes are 30 μl (ÄKTA) and 10 μl (Ettan).

The default values for the flush volume are 40 μl (ÄKTA) and 10 μl (Ettan).

The recommended flush volume with an air segment is 35 μl .

Note: *When an air segment is selected from the InjectionPickup_905 instruction in Manual:Flowpath, 5 μl of air is injected together with the sample. Thus, the air segment option should NOT be selected when using micro-bore columns.*

4.3.4 Reproducibility and accuracy

Syringe size

If using a syringe that is larger than the recommended size, the accuracy will decrease.

Flushed loop

Flushed loop gives maximum reproducibility, but not maximum accuracy.

In Autosampler A-905 for ÄKTA, the minimum sample loss is > 1.5 ml (1.5 \times loop overflow + flush volume for needle).

In Autosampler A-905 for Ettan, the minimum sample loss is 70 μl (3 \times loop overflow + flush volume for needle).

Partial loopfill

Partial loopfill gives maximum accuracy and reproducibility better than 0.5% RSD for injection volumes > 5 μl .

In Autosampler A-905 for ÄKTA, the minimum sample loss is 30 μl .

In Autosampler A-905 for Ettan, the minimum sample loss is 70 μl (3 \times loop overflow + flush volume for needle).

The minimum sample loss (flush volume) is 30 μl (ÄKTA) or 10 μl (Ettan).

μl pick-up

μl pick-up offers zero sample loss and maximum accuracy (same as partial loop fill), but slightly less reproducibility. RSD is better than 1% for injection volumes > 5 μl .

4.3.5 Injection volumes smaller than 20 µl

Use a **100 µl syringe** and a **5 µl sample needle** to obtain maximum reproducibility and accuracy. Use a **20 µl sample loop** to avoid loss of accuracy due to expansion of the loop content when switching from inject to load position prior to sample loading. This is especially recommended when working with high pressures (15.0–25.0 MPa).

The maximum injection volumes will be:

Flushed loop:	20 µl	(sample loss remains 70 µl since loops > 10 µl need 3 × loop volumes + 10 µl flushed volume)
Partial loopfill:	10 µl	(50% of loop volume)
µl pick-up:	2.5 µl	

The minimum sample loss in partial loopfill mode is 10 µl (minimum flush volume) for the injection. For zero sample loss injections, use the µl pick-up injection mode.

Note: *If using a syringe that is larger than the recommended size, the accuracy will decrease.*

Note: *The maximum injection volume in µl pick-up injection mode is 2.5 µl when using a 20 µl sample loop. For larger injection volumes, use a 100 µl sample loop!*

Note: *When injecting small volumes in µl pick-up mode, always use syringe speed LOW.*

4.3.6 Injection volumes up to 200 µl

Use a **250 µl syringe**, a **15 µl needle**, and a **500 µl buffer tubing** together with a **200 µl sample loop**.

The maximum injection volumes will be:

Flushed loop:	200 µl	(sample loss remains 230 µl since loops > 100 µl need 2 × loop volumes + 30 µl flushed volume)
Partial loopfill:	100 µl	(50% of loop volume)
µl pick-up:	77 µl	

4.3.7 For volumes larger than 200 µl

Select the syringe size according to the recommendation below:

Syringe volume > 2 × injection volume.

Injection volumes larger than 500 µl are possible, but the sample might contaminate the syringe. Program sufficient wash after use!

Follow the recommendations in the table below for choosing the appropriate buffer tubing and sample loop:

<i>Syringe</i>	<i>Buffer tubing</i>	<i>Loop volume</i>
100 µl	500 µl buffer tubing	5–20 µl
250 µl	500 µl buffer tubing	20–200 µl
500 µl	2000 µl buffer tubing	200–500 µl
1000 µl	2000 µl buffer tubing	500–1000 µl

4.4 Replacing the sample needle

To replace the sample needle, proceed as follows:

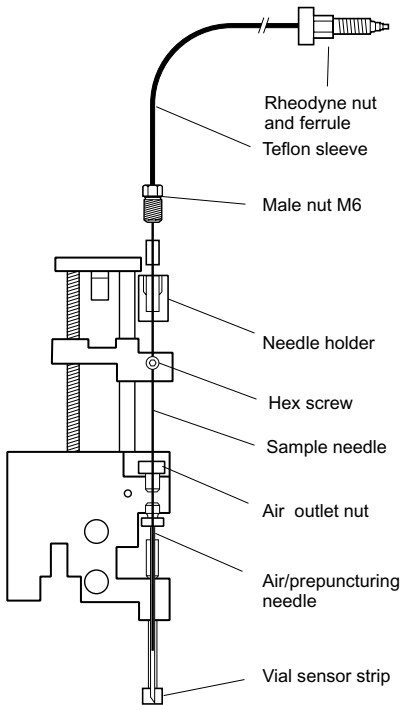

- 1 Use the `AutosamplerControl_905:NeedleFront_9051` command in `Manual:Flowpath` to move the needle to the front.
- 2 Loosen the needle connection nut (Male nut M6) that fixes the sample needle.

CAUTION! Do not loosen or otherwise unscrew the Hex screw!

- 3 Loosen the Rheodyne Rheflex nut that connects the tubing to the injection valve.
- 4 Remove the sample needle by pulling it out of its fitting.
- 5 Put in the new needle assembly.
- 6 Connect the loose end of needle connection tubing to port 4 of the injection valve (use a ferrule made of PEEK).

CAUTION! Do not tighten excessively—it might block the tubings.

- 7 Check the sample needle height, i.e. the distance between the needle tip and the black support plate. The default value for the needle height is 5 mm.

If it is possible to see the needle in the well or the vial, do an injection and check the needle height.

- 8 The needle height is adjusted in `System:Settings...:Specials:Needleheight_905` in UNICORN.
- 9 Wash to clean the new needle by issuing the `AutosamplerControl_905:InitialWash_9051` command in `Manual:Flowpath`.

¹ The instruction name does not contain “_905” in Autosampler for Ettan.

4.5 Syringe

Autosampler A-905 is factory-equipped with a 1 ml syringe (ÄKTA) or a 100 µl syringe (Ettan). 250 µl and 500 µl syringes can also be used.

To install another syringe, proceed as follows:

Note: Do not disconnect the power supply of the A-905. It is needed to move the syringe.

Note: After the syringe change, the syringe must be in HOME position.

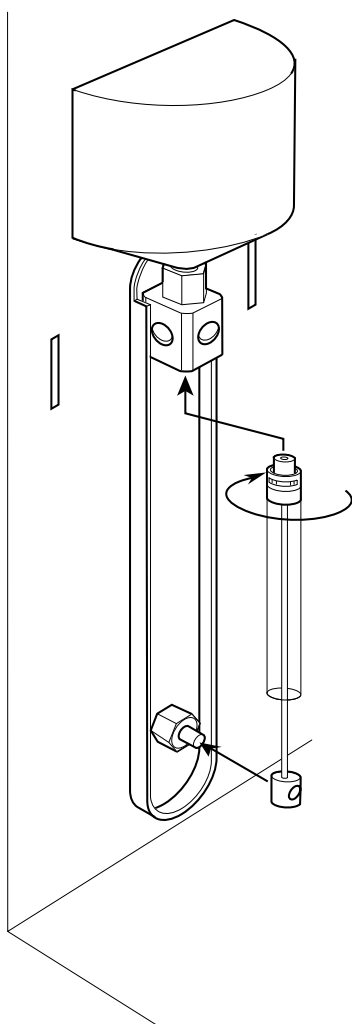

- 1 Move the syringe to the end position by issuing the `AutosamplerControl_905:SyringeEnd_9051` command in `Manual:Flowpath`.
- 2 Unscrew the syringe from the syringe valve. Make sure that the Luer connector in the valve remains in place.
- 3 Disconnect the plunger from the syringe drive.
- 4 Fill the new syringe with wash solvent. Remove the air bubbles from the syringe.
- 5 Connect the plunger of the filled syringe to the syringe drive and connect the syringe with the Luer connector at the syringe valve.
- 6 Screw the syringe firmly into the Luer connector.
- 7 Remove the air from the syringe by issuing the `AutosamplerControl_905:SyringeHome_9051` command `Manual:Flowpath`. The syringe will move to its HOME position and dispense its contents to the syringe waste.
- 8 If some air remains in the syringe, issue the `AutosamplerControl_905:SyringeEnd_9051` command in `Manual:Flowpath` again. The syringe is filled with wash solvent.
- 9 Issue the `AutosamplerControl_905:SyringeHome_9051` command in `Manual:Flowpath` to dispense the wash solvent to waste. If there is still air in the syringe, repeat the previous action and tap gently on the syringe as the wash solvent is dispensed to the syringe waste.

The A-905 is now ready for use.

¹ The instruction name does not contain “_905” in Autosampler for Ettan.

5 Troubleshooting



WARNING! Always disconnect the power supply before attempting to replace any item on the instrument.



WARNING! The instrument must not be opened by the user. It contains high voltage circuits that can deliver a lethal electric shock.

CAUTION! Only spare parts approved or supplied by Amersham Biosciences may be used for maintaining and servicing the instrument.

5.1 Faults and actions

Note: *The instruction names does not contain “_905” in Autosampler for Ettan.*

If the suggested actions do not correct the fault, call your local Amersham Biosciences representative.

Fault	Possible cause	Corrective action
Bad reproducibility	Injection valve switched dry	Replace rotor seal
	Syringe valve coupling leaking	Check and tighten coupling. Replace if necessary.
	Little or no peak	Syringe leaking problem. Replace syringe.
	Peaks of different height	Ferrule not tightened in injection valve. Tighten ferrule.
	Air in the syringe	Check and tighten coupling. Remove the air by issuing the AutosamplerControl_905: SyringeEnd_905 and AutosamplerControl_905: SyringeHome_905 commands in Manual:Flowpath . If there is still air in the syringe, remove it according to section 4.5.
Injection valve switches to slowly	Rotor worn	Replace rotor

Fault	Possible cause	Corrective action
Syringe action failed, motor generates noise	Syringe not tightened enough when replaced	Tighten syringe
Sample needle bent. No injection performed	Septa type wrong, septa deformed or needle depth set too low	Replace needle and readjust needle depth if necessary
Error message during initial wash	Syringe valve not properly switched	Check syringe installation. Refit if necessary.
Needle destroyed in injection using μ l vial segments	Segments badly oriented, or septa bent down	Replace needle
Ghost peaks at high pressure	Bad capillary connections	Replace connectors if necessary
A-905 does not execute commands	Syringe in END position	Order the syringe to HOME position using the AutosamplerControl_905: SyringeHome_905 command in Manual:Flowpath
No sample injected	Syringe in END position	Order the syringe to HOME position using the AutosamplerControl_905: SyringeHome_905 command in Manual:Flowpath .
	Wrong vial position programmed	Program correct position
	Wrong syringe or loop selected in UNICORN	Change the selection in UNICORN
Ghost or unexpected peaks	Washing not performed properly	If the wash bottle is empty, fill the bottle with washing liquid
		If washing liquid flows back in washing position, check that the waste bottle is not located below A-905
Bad separation of the peaks in the beginning of an isocratic run	Concentration of eluent B in the transport vial too high	Use a transport liquid with a concentration that is 20% lower than the concentration of the B eluent during the run. For example, if the eluent concentration is 60%B, use 48%B in the transport vial.

Table 5-1. Troubleshooting guide

6 Reference information

6.1 Description

6.1.1 General

A unique sequence of valve switching and syringe dispenser controlled sample withdrawal enables Autosampler A-905 to inject sample in a simple and reproducible manner. Sample volumes down to 1 μl (Autosampler A-905 for ÄKTA) or 0.1 μl (Autosampler A-905 for Ettan) can be injected .

Three different methods for injection can be selected:

- μl pick-up After aspiration from the vial, the sample volume is transported into the loop with transport liquid (mobile phase) from another vial resulting in no sample loss.
- Flushed loop The sample loop is completely (quantitatively) filled with sample resulting in extremely good reproducibility (better than 0.3%).
- Partial loopfill The sample loop is partially filled with sample giving low sample loss and allowing programmable injection volumes.

Autosampler A-905 uses a syringe to aspirate the sample from a vial into the sample loop. To prevent contamination of the syringe, A-905 is equipped with a buffer tubing between the syringe and the injection valve.

The wash solvent removes the sample from the buffer tubing and sample needle and also rinses both components.

Autosampler A-905 also provides active cooling of the sample vials. This is accomplished by a Peltier element located under the vial rack and a fan at the rear of the unit.

6.1.2 Autosampler A-905

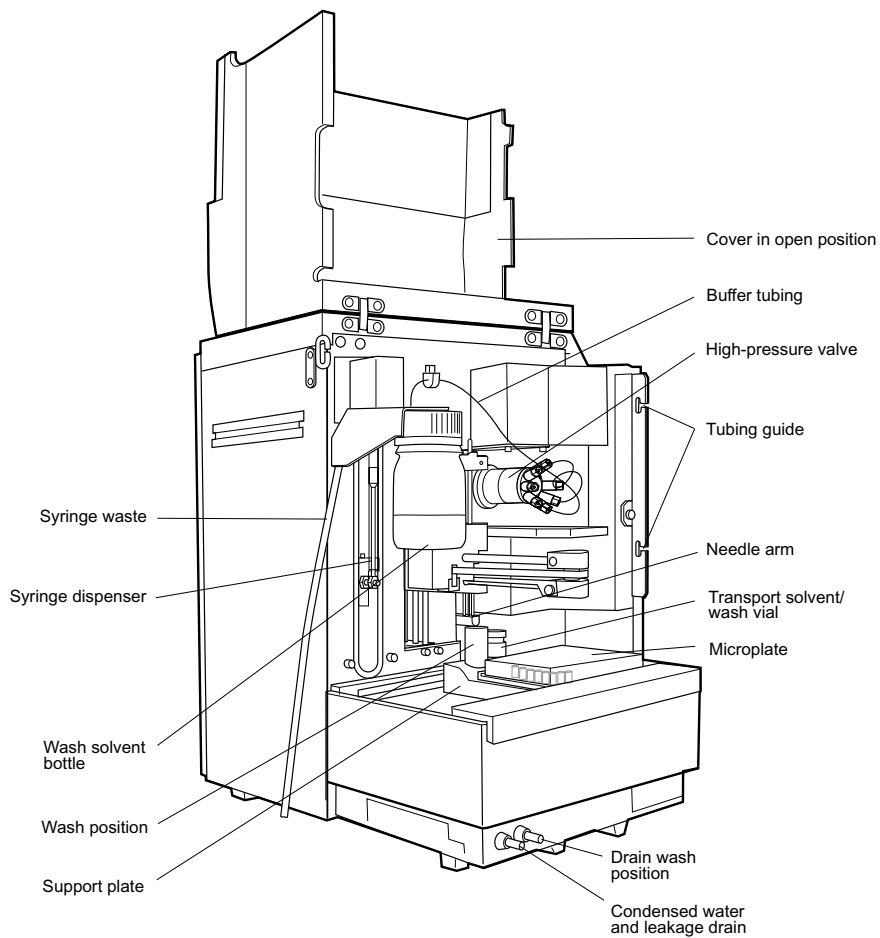

Fig. 6-1. Autosampler A-905

6.1.3 Rear view

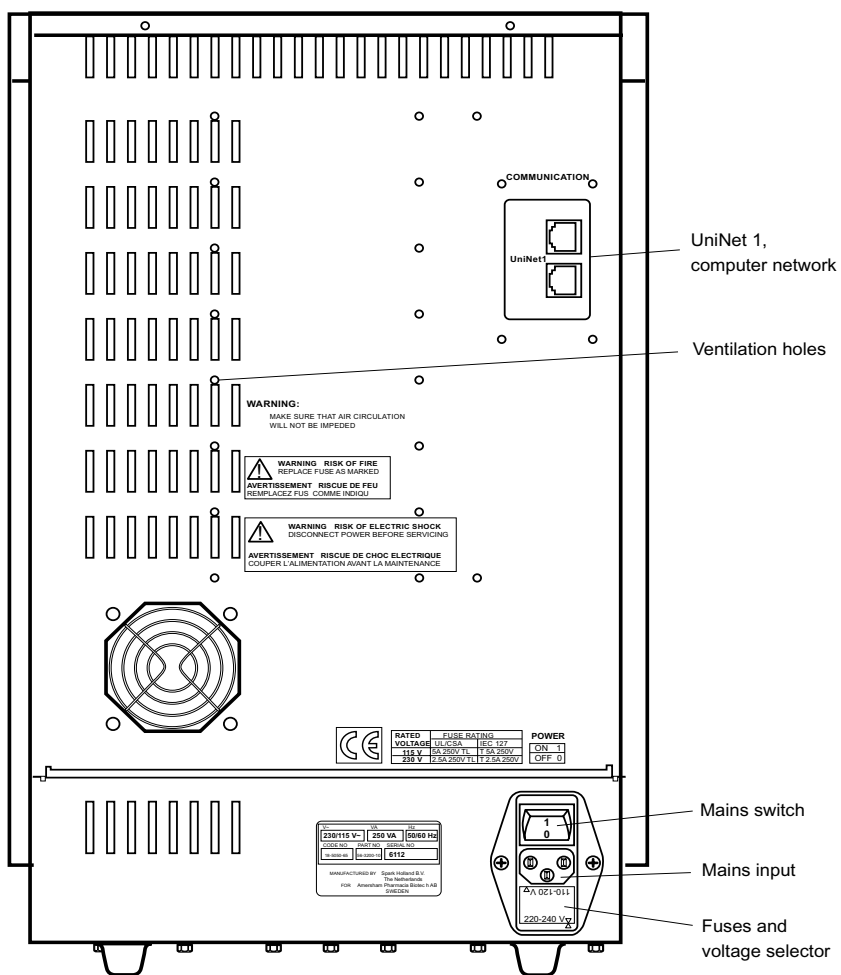
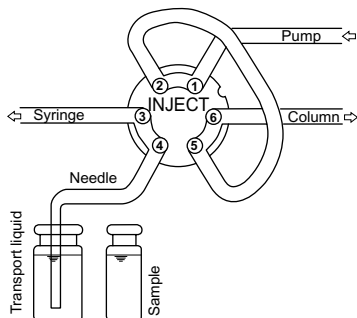

Fig. 6-2. Autosampler A-905, rear view

6.1.4 μl pick-up injections

The switching sequence for a μl pick-up injection is schematically shown in the following figures. The default position of the injection valve is always INJECT.



The injection valve is initially in the INJECT position. The sample needle has entered the vial of transport liquid (mobile phase used to avoid disturbing the chromatogram with an additional peak of the transport solvent).

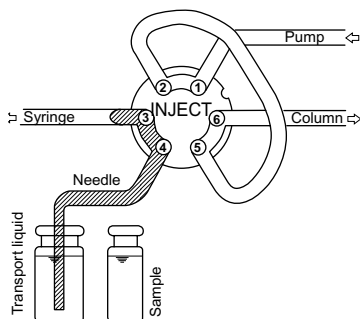

The syringe dispenser aspirates transport liquid from the transport vial to fill the sample line with transport liquid and remove wash solvents.

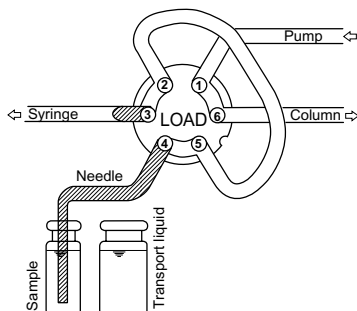

The needle moves from the transport vial to the sample vial. The injection valve switches to the LOAD position.

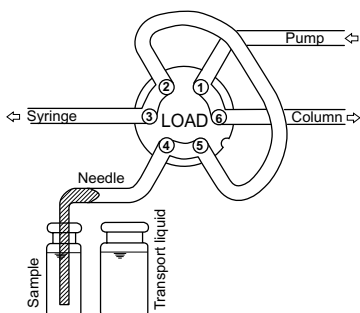

The programmed injection volume is aspirated from the sample vial.

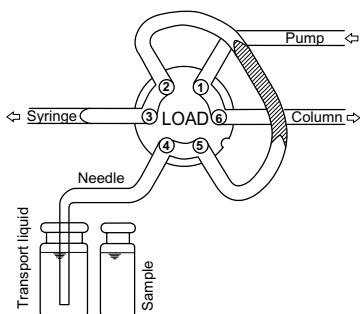

The sample needle moves back to the transport vial. The sample is quantitatively transported into the loop with transport liquid (mobile phase) from the transport vial.

The volume of transport liquid is 30 μl (Autosampler A-905 for ÄKTA) or 12 μl (Autosampler A-905 for Ettan).

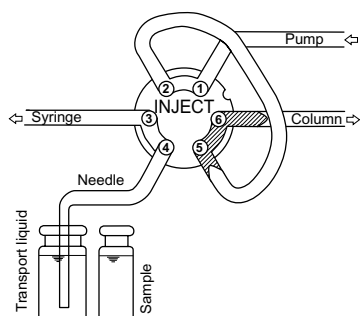

The injection valve switches to the INJECT position. The sample loop is now part of the system mobile phase flow path. Sample is transported to the column.

Air segment

Normally an air segment shall not be programmed for μl pick-up injections, since it then is injected with the sample into the system.

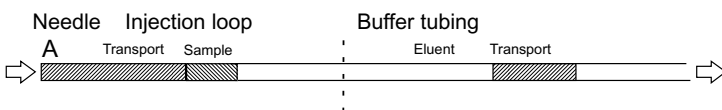

Note: When using micro-columns, an air segment should not be used.

6.1.5 Flushed loop injections

The switching sequence for a flushed loop injection is schematically shown in the following figures. The default position of the injection valve is always INJECT.

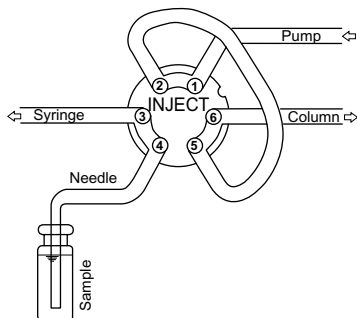

The injection valve is initially in the INJECT position. The sample needle and air needle have entered the vial. The head-space pressure, applied through the outer air needle, ensures that no air or vapour bubbles are formed during sample aspiration.

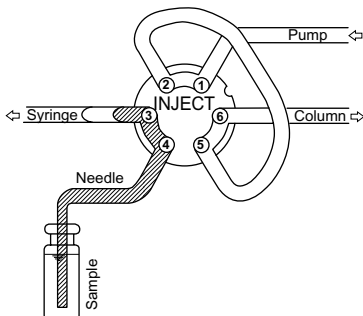

The syringe dispenser aspirates the “flush volume” from the sample vial to fill the sample lines with sample and remove wash solvent.

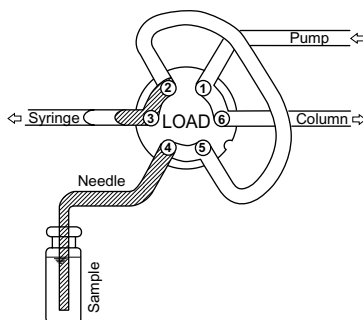

The injection valve switches to the LOAD position, placing a “sharp” sample front at the inlet of the sample loop.

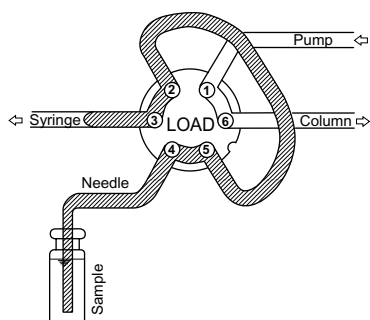

For flushed loop injections, the sample loop is quantitatively filled by transporting two or more times the loop volume through the loop, depending on the volume of the loop.

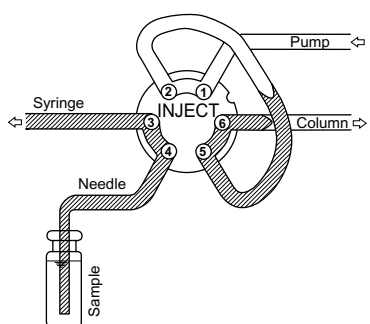

The injection valve switches to the INJECT position. The sample loop is now part of the system mobile phase flow path. Sample is transported to the column.

If one injection is to be made from each vial, a wash routine has to be performed after every injection.

Air segment

An air segment should be used to reduce the amount of flush volume. This air segment is at the front of the flush volume. It will not be injected and will therefore not influence the injection. The air segment is selected when the injection method is selected in **Manual:Flowpath**.

With a standard 15 µl needle, the flush volumes must be minimum 30 µl for injections with an air segment and 35 µl without. With a 5 µl needle the flush volume must be minimum 10 µl.

Note: *When using micro-columns, an air segment should not be used.*

If the samples are highly viscous, it might be necessary to use larger flush volumes and reduce the syringe speed to optimize performance.

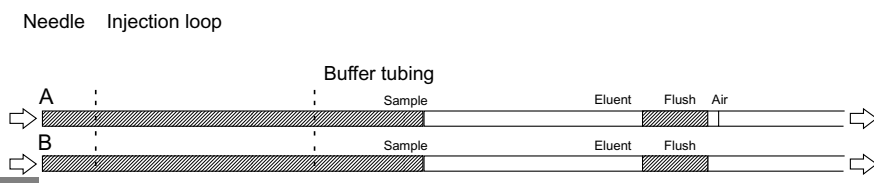

6.1.6 Partial loopfill injections

The switching sequence for a partial loopfill injection is schematically shown in the following figures. The default position of the injection valve is always INJECT.

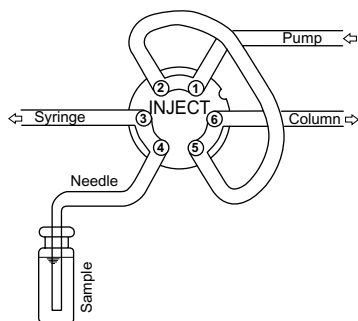

The injection valve is initially in the INJECT position. The sample needle and air needle have entered the vial. The head-space pressure, applied through the outer air needle, ensures that no air or vapour bubbles are formed during sample aspiration.

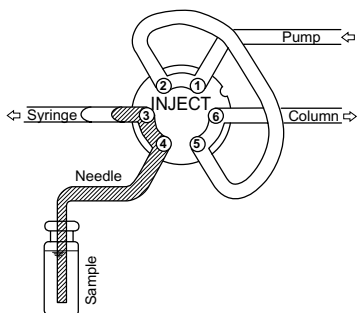

The syringe dispenser aspirates the "flush volume" from the sample vial to fill the sample lines with sample and remove wash solvent.

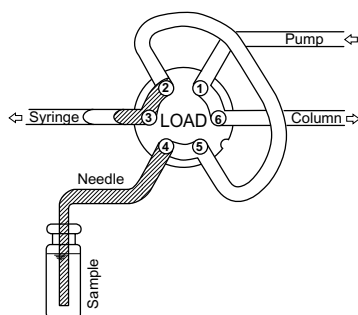

The injection valve switches to the LOAD position, placing a "sharp" sample front at the inlet of the sample loop.

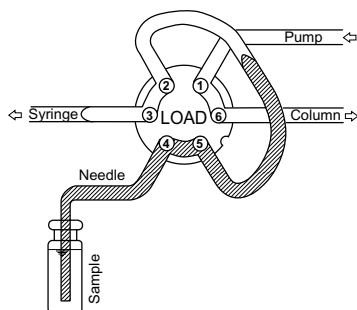

For partial loopfill injections, the sample loop is filled by transporting the programmed injection volume into the sample loop.

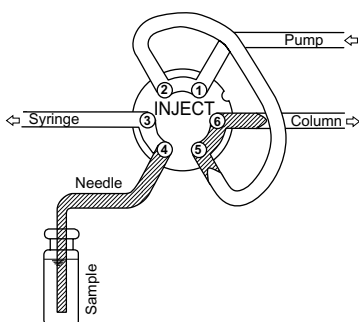

The injection valve switches to the INJECT position. The sample loop is now part of the system mobile phase flow path. Sample is transported to the column.

Air segment

An air segment should be used to reduce the amount of flush volume. This air segment is at the front of the flush volume and will not be injected. The air segment can be selected when the injection method is selected in **Manual:Flowpath**.

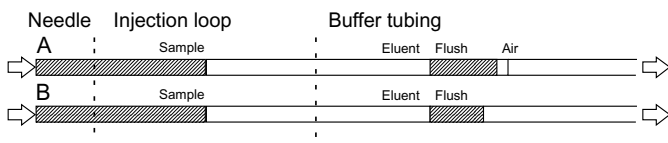

6.2 Technical specifications

Sampling

Sample capacity <i>96-well microplate (Low/High)</i> <i>384-well microplate</i> <i>48-vial adapter</i>	Direct filling or 96 micro vials Direct filling or 384 micro vials 48 vials
Maximum total plate height	47 mm (plate + vial + cap/sealing)
Minimum total plate height	12.5 mm (plate + vial + cap/sealing)
Vial dimensions (cap included)	Maximum vial height: 47 mm Minimum vial height: 12.5 mm
Loop volume	5–1000 μl
Dispenser syringe	100 μl ¹ , 250 μl , 500 μl , 1000 μl ²
Plate detection	Missing plate detection by vial sensor
Headspace pressure	Built-in compressor
Switching time injection valve	Electrically < 100 ms
Piercing precision needle	± 0.6 mm
Wash solvent	100 ml internal wash solvent bottle
Wetted parts	PEEK, PTFE, glass, Tefzel, aluminum ceramic and inert polymer

¹ Standard in Autosampler A-905 for Ettan.

² Standard in Autosampler A-905 for ÄKTA.

Analytical performances

Reproducibility	RSD \leq 0.3% for flushed loop injections RSD \leq 0.5% for partial loopfill injections, injection volumes > 5 μl (5 μl sample, 100 μl sample loop, \leq 2.5 MPa) RSD \leq 1.0% for μl pick-up injections, injection volumes > 5 μl
Memory effect	< 0.1% with programmable needle wash
Cooling capacity	Max. 12 °C below ambient temperature (T) for 16 °C < T < 40 °C

Physical data

Dimensions (W x D x H)	280 × 400 × 440 mm
Weight	26 kg

Electrical data

Power supply voltage	100–240 V~, 50–60 Hz
Power requirement	250 VA
Fuses For 100–120 VAC For 220–240 VAC	Two 5.0 AT-fuses (slow, "x", UL/CSA) Two 2.5 AT-fuses (slow, 5 × 20 mm, IEC 127)

Communication

Serial communication port	UniNet-1
---------------------------	----------

Environment

Working condition	+4 to +40 °C 20–95% relative humidity
Sound pressure level	< 70 dB (A)
Installation category	Category II, according to IEC 1010
Pollution degree	Degree 2, according to IEC 1010

6.3 Accessories and consumables

<i>Item</i>	<i>Quant./pack</i>	<i>Code no.</i>
Rheflex ferrule	10	18-1119-91
Rheflex nut	10	18-1119-92
Flange tube fitting 1/8"	5	18-1119-93
Flange tube fitting 1/16"	5	18-1119-94
Plunger replacement tip 100 µl	10	18-1119-96
Plunger replacement tip 250 µl	10	18-1119-98
Sample needle, PEEK, 15 µl	1	18-1119-99
Sample needle, fused silica, 5 µl	1	18-1158-68
Buffer tubing 500 µl	1	18-1120-32
Buffer tubing 2000 µl	1	18-1120-31
Syringe 100 µl	1	18-1120-34
Syringe 250 µl	1	18-1120-35
Syringe 500 µl	1	18-1120-36
Syringe 1000 µl	1	18-1120-37
Luer lock connection, female	1	18-1120-38
PEEK loop 20 µl	1	18-1160-49
PEEK loop 100 µl	1	18-1120-40
Valve, Valco micro C2-1346-SPHT (used in Autosampler A-905 for Ettan)	1	18-1157-51
Rotor seal, Valco	1	18-1157-52
Rotor, PEEK (for Rheodyne 9740 valve, used in Autosampler A-905 for ÄKTA)	1	18-1120-41
Syringe waste tubing	1	18-1120-44
Syringe tubing	1	18-1120-45
Wash vial	1	18-1120-46
Union nut air	1	18-1120-47
Stop plug, 1/16"	5	18-1112-52
Union Luer female/1/16" male	2	18-1112-51
Union 1/16" female/M6 male	6	18-1112-57
Union M6 female/1/16" male	8	18-1112-58

6

Reference information

<i>Item</i>	<i>Quant./pack</i>	<i>Code no.</i>
PEEK tubing, i.d. 0.15 mm, o.d. 1/16"	2 m	18-1156-59
PEEK tubing, i.d. 0.25 mm, o.d. 1/16"	2 m	18-1120-95
PEEK tubing, i.d. 0.50 mm, o.d. 1/16"	2 m	18-1113-68
Tefzel tubing, i.d. 0.25 mm, o.d. 1/16"	2 m	18-1121-36
Tefzel tubing, i.d. 0.50 mm, o.d. 1/16"	2 m	18-1120-96
Teflon tubing, i.d. 0.75 mm, o.d. 1/16"	2 m	18-1112-54
Capillary tubing kit, i.d. 75 µm, for Ettan microLC	4	18-1157-57
Tubing kit, fused silica, i.d. 0.10 mm, for Ettan LC	3	18-1147-13
Tubing kit, fused silica, i.d. 0.15 mm, for Ettan LC	3	18-1147-14
Fingertight connector, 1/16"	10	18-1112-55
Fingertight, narrow head connector, PEEK, for 1/16" o.d. tubing	10	18-1147-10
Sleeve, o.d. 1/16", PEEK, for o.d. 285 µm fused silica tubing	10	18-1156-63

For recommended microplates and transport vials, see section 2.7.2.

