



Isotemp

Forced Air Incubators
600 Series
Operation Manual and Parts List

LT2071X1 (7006842 Rev. 3)

© 2010 Fisher Scientific Inc.
All rights reserved
Printed in U.S.A.

Models covered in this manual		
Model number	Size	Voltage
11-690-637F (6842)	Medium	120V
11-690-638F (6844)	Medium	240V
11-690-650F (6846)	Large	120V
11-690-651F (6848)	Large	240V
11-690-625F (6859)	Small	120V
11-690-626F (6861)	Small	240V

MANUAL NUMBER LT2071X1 (7006842)

3	29775	4/2/13	Corrected model numbers on pgs 2-1 and 8-2	ccs
2	26697/SI-10360	11/23/10	Added Electrical Requirements note - includes 5 amp outlet - pg 2-1	ccs
1	SI-10360	6/29/10	Corrected model numbers above	ccs
0	--	4/27/10	Transfer to Marietta (was LT2071X1 3/9/09)	ccs
REV	ECR/ECN	DATE	DESCRIPTION	By



Important Read this instruction manual. Failure to read, understand and follow the instructions in this manual may result in damage to the unit, injury to operating personnel, and poor equipment performance. ▲

Caution All internal adjustments and maintenance must be performed by qualified service personnel. ▲

Material in this manual is for information purposes only. The contents and the product it describes are subject to change without notice. Fisher Scientific makes no representations or warranties with respect to this manual. In no event shall Fisher Scientific be held liable for any damages, direct or incidental, arising out of or related to the use of this manual.

©2010 Fisher Scientific. All rights reserved.



Important operating and/or maintenance instructions. Read the accompanying text carefully.



Potential electrical hazards. Only qualified persons should perform procedures associated with this symbol.



Equipment being maintained or serviced must be turned off and locked off to prevent possible injury.



Hot surface(s) present which may cause burns to unprotected skin, or to materials which may be damaged by elevated temperatures.



Marking of electrical and electronic equipment, which applies to electrical and electronic equipment falling under the Directive 2002/96/EC (WEEE) and the equipment that has been put on the market after 13 August 2005.



This product is required to comply with the European Union's Waste Electrical & Electronic Equipment (WEEE) Directive 2002/96/EC. It is marked with the WEEE symbol. Fisher Scientific has contracted with one or more recycling/disposal companies in each EU Member State European Country, and this product should be disposed of or recycled through them. Further information on Fisher Scientific's compliance with this directive, the recyclers in your country and information on Thermo products will be available at www.fishersci.com.

- ✓ Always use the proper protective equipment (clothing, gloves, goggles, etc.)
- ✓ Always dissipate extreme cold or heat and wear protective clothing.
- ✓ Always follow good hygiene practices.
- ✓ Each individual is responsible for his or her own safety.

Do You Need Information or Assistance on Fisher Scientific Equipment?

The Fisher Scientific Sales Group can provide information on pricing and give you quotations. We can take your order and provide delivery information on major equipment items or make arrangements to have your local sales representative contact you. Our products are listed on the internet and we can be contacted through our Internet home page.

1-800-766-7000
www.fishersci.com

Customer Service
To order online

Fisher Scientific Product Service Support can supply technical information about proper setup, operation or troubleshooting of your equipment. We can fill your needs for replacement parts or provide you with on-site service. We can also provide you with a quotation on our Extended Maintenance Program for our products.

Whatever products you need or use, we will be happy to discuss your applications. If you are experiencing technical problems, working together, we will help you locate the problem and, chances are, correct it yourself...over the telephone without a service call.

When more extensive service is necessary, we will assist you with direct factory trained technicians or a qualified service organization for on-the-spot repair. If your service need is covered by the Fisher Scientific Products warranty, we will arrange for the unit to be repaired at our expense and to your satisfaction.

Regardless of your needs, professional service technicians are available by telephone to assist you concerning our products Monday through Friday from 8:00 a.m. to 6:00 p.m. Eastern Time. Please call or fax us at:

1-800-766-7000
1-800-926-1166

Customer Service
Orders Fax

International customers, please contact your local Fisher Scientific distributor.

Table of Contents

Section 1	Introduction	1-1
Section 2	Specifications	2-1
Section 3	Installation	3-1
	Unpacking	3-1
	Convenience Outlet	3-2
	Power Switch	3-2
	Preparing the Incubator	3-2
Section 4	Controls	4-1
	Keypad	4-2
Section 5	Operation	5-1
	Alarm Limits	5-2
	Safety Precautions	5-2
	Display Offsets	5-3
Section 6	Service	6-1
	Cleaning	6-1
	Replacing the Door Gasket	6-2
	Replacing the Heater	6-3
	Accessing the Electronics	6-3
	Replacing the Circulating Fan Motor	6-4
	Replacing the Cooling Fan	6-4
	Replacing the Controller	6-6
	Replacing the Solid State Relay	6-6
	Replacing the Safety Relay	6-7
	Replacing the Control Thermocouple	6-7
	Adjusting Door Cam	6-9
	Replacing the Door Handle	6-9
	Replacing the Glass Door	6-9
Section 7	Troubleshooting	7-1
Section 8	Replacement Parts	8-1
Section 9	Schematic	9-1

Section 1 Introduction

Fisher Isotemp 600 Series Forced Air Incubators are available in three sizes: Small, Medium and Large. All incubators provide PID microprocessor control at operating temperatures ranging from 30 (86°F) to 75°C (167°F).

Note Ambient temperature must be at least 5°C below operating temperatures. ▲

In these units, air is uniformly circulated throughout the chamber by a fan located at the bottom of the unit. An intake port located under the incubator chamber allows fresh air to enter the unit. The fresh air is heated in a

plenum and then is circulated throughout the chamber.

Exhaust air exits through a port at the top of the chamber.

Temperature readouts and control parameters are shown in red LED's. Three additional LED's indicate when the heater power is being applied, an error condition is encountered, or the temperature is being set.

The Small incubator accommodates a maximum of three shelves. The Medium incubator holds six shelves, and the Large incubator holds 10 shelves.

Isotemp incubators incorporate a variety of safety features. A safety backup is built into the controller software. If the primary heater control fails, the backup will maintain control at 3°C above the set point. An alarm LED then indicates that the backup controller is operating the incubator. A circuit breaker protects the incubator from power surges.

Section 2 Specifications

Operating Range30° to 75°C

Note Operating temperature must be at least 5°C above ambient. ▲

Average Uniformity @ 37°C*±0.3°C

Resolution0.1°C

Control Sensitivity±0.1°C

Recovery Time @ 37°C (door opened 30 seconds)

Small incubator2.0 minutes

Medium incubator2.0 minutes

Large incubator3.0 minutes

**When tested per ASTM E-1292-94*

Operating Environment

Temperature Range10° to 35°C

Humidity Range (non-condensing) . . 0% to 90% RH

Electrical Requirements (includes 5 amp outlet)

Small incubators

11-690-625F120V, 60 Hz, 8.3A, 996W

11-690-626F240V, 50/60 Hz, 6.6A, 1560W

Medium incubators

11-690-637F120V, 60 Hz, 8.3A, 996W

11-690-638F240V, 50/60 Hz, 6.16A, 1560W

Large incubators

11-690-650F120V, 60 Hz, 8.9A, 1068W

11-690-651F240V, 50/60 Hz, 7.0A, 1680W

Chamber Volumes

Small incubators2.2 cu ft
Medium incubators3.4 cu ft
Large incubators4.5 cu ft

Chamber Dimensions (W x D x H)

Small incubators18 x 18 x 12.5 in
Medium incubators18 x 18 x 19 in
Large incubators18 x 18 x 25.5 in

Environmental Conditions

Indoor use only

Operating: 17°C to 27°C; 20% to 80% RH, non-condensing.

Installation Category II (overvoltage) in accordance with IEC 664.

Pollution Degree 2 in accordance with IEC 664.

Altitude Limit: 2,000 meters.

Storage: -25°C to 65°C, 10% to 85% relative humidity (RH)

Section 3 Installation

Choose a location for the incubator that will provide an area of approximately 30 inches by 30 inches. Allow at least 2" of open space on both sides and back of unit (six inches if combustible materials). The bench or table selected must be capable of supporting at least 120 lbs. for the Small incubators, 140 lbs. for the Medium incubators, or 160 lbs. for the Large incubators. Appropriate electrical power must be available. Locate the incubator within three feet of the power outlet so that no extension cord is required.

Note If the equipment is not used in the manner specified by the manufacturer, the protection provided by equipment may be impaired. ▲

Unpacking

Fisher Scientific Isotemp® Incubators are shipped in a single carton. After unpacking, locate each item shown in the list below. Report any missing items, by name and part number, to your Fisher Scientific distributor. In the event of shipping damage, retain the carton and packing material and file a claim with the final carrier.

Item

Shelves

Small and Medium - one provided

Large - two provided

Shelf Supports

Small and Medium - two provided

Large - four provided

Preparing the Incubator

To prepare the incubator for operation, perform the following procedures:

1. Install the shelf(s).
2. Make certain all packing material has been removed from incubator chamber.
3. Connect the line cord to an appropriate electrical outlet.
4. The incubator is now ready for operation. No preliminary adjustments are required. Depending on the customer application and customer laboratory procedures, an initial calibration may be done at this point.

Caution See data plate on incubator for voltage, current and line frequency specifications. Check that the power requirements of the incubator will not overload the circuit. ▲

Power Switch

The 600 Series incubators feature a front panel mounted power switch which is a combination power switch and circuit breaker, eliminating the need for separate fusing. The circuit breaker will interrupt power in the event of an incubator heater malfunction.

Press in the I (upper) half of the rocker-type power switch to turn the incubator on. Press in the 0 (lower) half to turn off incubator power.

To reset the breaker, first press the switch into the Off position, then return it to the On position.



Convenience Outlet

The 600 Series incubators feature a convenience electrical outlet located inside the incubator, at the lower right of the back panel. This outlet is rated at the same voltage as the incubator itself and is limited to a maximum current of 5A for all incubators. If the current limit is exceeded, the circuit breaker will trip. For safety, the integrity of the electrical ground should always be maintained.

Section 4 Controls

The following sections briefly describe the locations and functions of various display fields and keypad controls. More detailed descriptions are provided, when required, in the operation sections of this manual.

The 600 Series controller features two bright, one-half inch, 7-segment LED displays used in setting up the incubator program or reading incubator temperature. Two smaller LEDs indicate, respectively, an alarm condition or when power is being applied to the incubator heaters. Each display field is discussed separately below.

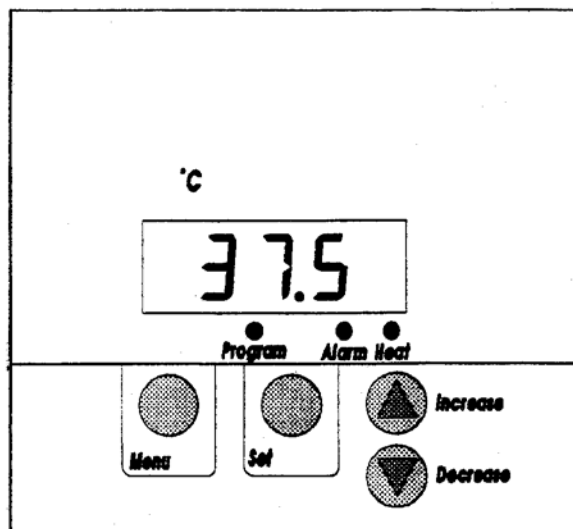

Figure 4-1. Display Fields

Temperature Display In the normal operating mode, shows the current incubator temperature. During programming, indicates the incubator set temperature target.

Heat Indicator Lights when power is being supplied to the incubator heater.

Alarm Indicator Lights if the actual incubator temperature exceeds the alarm temperature. The alarm temperature is factory-adjusted to be 3°C above the set temperature.

Program Indicator Lights when the control temperature is being set.

Keypad

The 600 Series incorporates a four-key, tactile keypad. The function of each key is discussed individually below. Refer to Figure 4-1 on the previous page.

Pressing the **MENU** Key will cause display to show CAL. Then pressing SET Key will display calibration.

Pressing **INCREASE** Key while holding down the SET Key increases the incubator set temperature, as indicated on the temperature display.

Pressing the **DECREASE** Key while holding down the SET Key decreases the incubator set temperature, as indicated on the temperature display.

Pressing the **SET** Key causes the display to show the set temperature. Used with INCREASE Key and DECREASE Key to change the set temperature. With MENU Key to access entry of a temperature display offset (calibration feature).

Section 5 Operation

In Control mode operation, the incubator maintains a set temperature until that set temperature is changed. The Actual and Set Displays will indicate current chamber temperature and the temperature set point, respectively. To set a temperature and initiate Control mode operation, perform the following

1. Place the power switch in the ON position. All 8s will flash as a test of the display.
2. Press and hold the SET Key.
3. Observe the set temperature in the Set Display window.
4. To decrease the set temperature, press the DECREASE Key while holding the SET Key.
5. To increase the set temperature, press the INCREASE Key while holding the SET Key.
6. When the desired set temperature is shown, release the INCREASE OR DECREASE Key. Finally, release the SET Key. The incubator automatically begins to control at the set temperature.

Note To rapidly increase or decrease the set temperature, press and hold the appropriate key. To slowly increment or decrement the set temperature 1° at a time, press and immediately release the key. ▲

Note Upon initial heat up to temperature, the over range alarm indicator light may illuminate briefly (several minutes) until the temperature stabilizes at the set point. The incubator temperature should be allowed to stabilize prior to loading samples. ▲

Safety Precautions

Before operating the incubator, always observe the following Safety Precautions:

This unit is not explosion proof. Do not use in the presence of flammable or combustible materials; fire or explosion may result. Unit contains components, which may ignite such materials.

Fumes and spillage from acidic solutions cause corrosion of the stainless steel chamber and other components. Care should be taken to maintain a neutral pH at all times.

The heater is in the bottom of the unit. Surface temperatures at the bottom cover may be higher than set point temperature.

For Example: A plastic container setting on the heater cover may become hot enough to melt/burn the container at settings below the melting point of plastic. Do not place items on the heater cover.

- Wear insulated gloves
- Use tongs
- Never stand in front of an open incubator
- Use safety goggles

Alarm Limits

The 600 Series controllers feature a deviation alarm which alerts the operator and interrupts heater power whenever the actual incubator temperature differs from the set temperature by more than 3°C. This set limit cannot be adjusted by the operator.

If the actual temperature exceeds the alarm limit, the alarm indicator LED will light and the Display will flash “EEE.”

The reference point for the alarm is the set temperature. Any change in the set temperature will cause a corresponding shift in the alarm temperature.

Example:

If the set temperature is 40°C, the alarm will trip at 43°C. If the set temperature is changed to 50°C, the alarm will follow the set temperature and trip at 53°C.

(continued)

Alarm Limits (continued)

Changing the set temperature to a value more than 3°C below the present incubator temperature, will trip the alarm. Power is removed from the heater when an alarm condition occurs.

As an example:

An experiment was being run at 50°C. The experiment finished and another researcher needed to run an experiment at 40°C. The researcher reset the set point to 40 and the unit went into alarm. The researcher, knowing this was a normal operation, allowed the unit to cool and stabilize at 40°C. Just below 43°, the unit alarm LED went off and the display resumed normal operation.

Display Offsets

The 600 Series controllers permit the operator to select a display offset temperature. With a display offset entered, the temperature displayed will be the actual incubator temperature (measured at the control thermocouple) plus or minus the display offset selected. Functionally, the offset feature permits the operator to measure and calibrate such that the display will indicate the temperature at a specific point or zone within the incubator.

To enter a display offset, perform the following steps:

1. Press the MENU Key, the display will indicate –.
2. To view the present offset value, press and hold the SET Key.
3. To change the display offset, press and hold the SET Key. Press the INCREASE Key or DECREASE Key until the display indicates the desired offset.
4. Release the SET Key.
5. Press MENU Key Once to return to normal temperature control.

Example:

The displayed temperature is the result of algebraically adding the actual temperature to the offset value. Thus, if an offset value of -3° is being used, a measured temperature of 50° will be displayed as 47°.

Section 6 Service

The following sections describe procedures for servicing the 600 Series incubators. The procedures, Replacing the Door Gasket, Replacing the Door handle, and Adjusting the Door Handle may be performed by most users. However, all other service procedures involve possible exposure to line voltage. Only qualified service personnel should undertake these procedures. The second section, Accessing the Electronics Compartment, describes procedures required for subsequent service sections and is referenced by these later sections when required.

Caution Service procedures involve exposure to line voltage and should be performed only by qualified service personnel. Disconnect incubator from power source before attempting repairs. ▲

Caution Only factory authorized components should be used for all repairs. Failure to use factory authorized replacement components will void warranty and could result in unit malfunction and or hazardous operating conditions. ▲

Caution Allow incubator to cool to ambient temperature before attempting repair. ▲

For assistance, call Technical Services.

Cleaning

1. Always unplug unit prior to cleaning
2. During cleaning, take precautions to prevent cleaning agents from contacting electrical components.
3. Use a mild, non-abrasive cleaner (i.e. damp cloth and mild soap) to clean all normally accessible surfaces.
4. Make sure unit is dry before re-connecting to power source.

Replacing the Door Gasket

Isotemp 600 Series incubators incorporate a durable, silicone door gasket to minimize heat loss. Should the gasket become defective or be damaged, it may be replaced by following the procedure below.

Note Study the method of door gasket attachment before starting disassembly. Understanding will avoid confusion later in this process. ▲

1. Set the power switch to off position and open chamber door.
2. Open door fully. Carefully remove and retain hardware from door hinges (case side). Lay door on a flat surface with the handle over the edge.
3. Note the joint position of the old gasket. This is where the new gasket installation will start.
4. Bend back the old door gasket and remove the Phillips head screws attaching the gasket.
5. Remove the old door gasket.
6. Loosely install two screws through the stainless steel liner and into the door wrap to align these pieces during the installation of the new gasket. Once one side of the new gasket is installed, these screws will need to be removed to install the new gasket.
7. Begin installing the replacement gasket at the joint position of the old gasket. Stretch the replacement gasket around the corners of the liner to avoid bunching up of the gasket material.
8. Install a Phillips head screw as the gasket rounds each corner to keep the gasket properly stretched. (The screw goes through the liner, pierces the gasket and threads into the door wrap.)
9. After all four corners are secured, install the remainder of the Phillips head screws. Make sure there is no gap at the gasket joint; stretch the gasket slightly, if necessary.
10. Reinstall the door onto the case with hinges.

Accessing the Electronics

To access the electronics compartment, proceed as follows:

1. Disconnect power cord from the electrical outlet. Carefully remove *and retain* hardware from door hinges (case side). Set door aside.
2. Slide the unit back until the front of the bezel (control panel) is at least 3 inches from edge of bench top.
3. Prop up the front of the incubator by placing a shim under each front foot. Use shims between 1½ and 2 inches in thickness.
4. Remove the screws securing bezel from bottom of the incubator.
5. Grasp bezel and pull top outward. Bezel will disengage from fascia. Lay bezel aside on bench top.

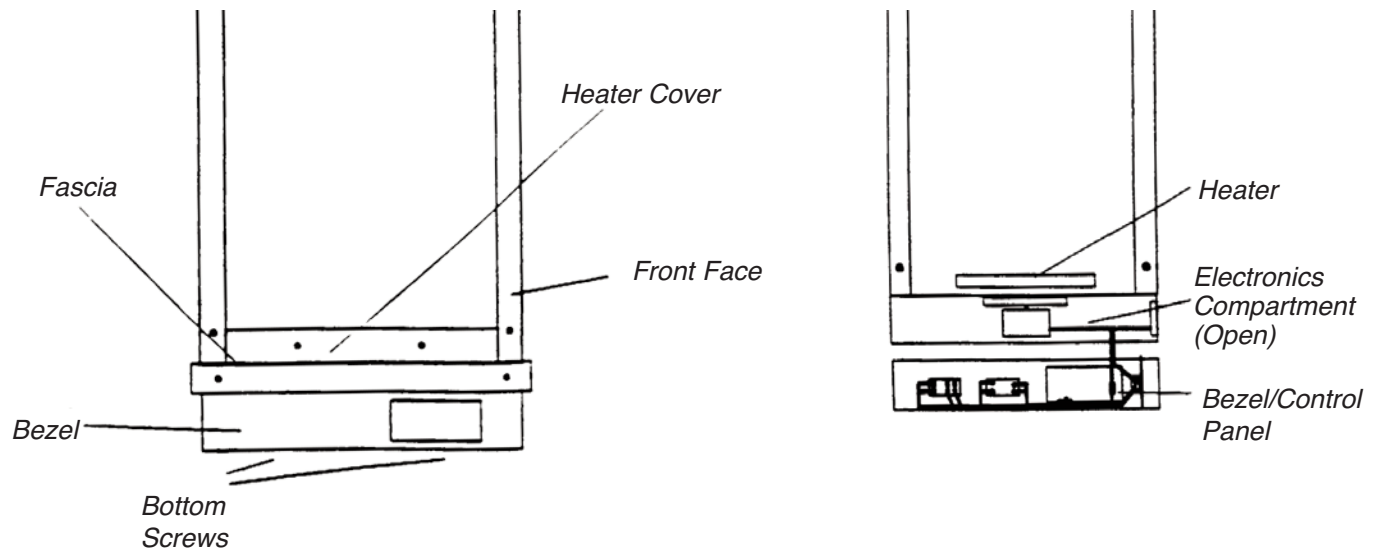

Figure 6-1. Locations

Replacing the Heater

To replace a defective heater, proceed as follows:

1. Disconnect power cord from the electrical outlet.
2. Remove the outer chamber door and glass door.
3. Remove the two screws that secure the plenum in place, then remove the plenum.
4. Remove the six screws that secure the heater cover. Remove the cover by lifting and sliding it forward. It may be necessary to use a flat-blade screwdriver to assist in lifting the cover upward. Set heater cover aside.

Note Carefully remove the temperature sensor from heater cover before removing the cover. ▲

Replacing the Heater (cont.)

5. Remove the nuts and shake-proof washers securing the heater leads, then pull the lead terminals off the heater studs.
6. Remove the two screws securing heater to cabinet. Slide heater forward to disengage back heater clips, lift back of heater up, then slide heater back and lift out.
7. Install replacement heater and reassemble unit by generally reversing the steps above.

Replacing the Cooling Fan

To replace a defective cooling fan, proceed as follows:

1. Disconnect power cord from the electrical outlet. Carefully remove *and retain* hardware from door hinges (case side). Set door aside.
2. Slide the unit back until the front of the bezel (control panel) is at least 3 inches from edge of bench top.
3. Prop up the front of the incubator by placing a shim under each front foot. Use shims between 1½ and 2 inches in thickness.
4. Remove the screws securing bezel from bottom of the incubator.
5. Grasp bezel and pull top outward. Bezel will disengage from fascia. Lay bezel aside on bench top.
6. Remove the two mounting screws holding the fan in place.
7. Remove the two fan power wires from push-on terminals located on fan housing.
8. Install replacement fan and reassemble oven by generally reversing the steps above.

Note When installing the replacement fan, make certain air flow arrow molded into fan housing points **out of the incubator chassis**. ▲

Replacing the Circulating Fan Motor

Caution Sheet metal in this area is sharp. Work carefully. ▲

To replace a defective circulating fan motor, proceed as follows:

1. Disconnect power cord from the electrical outlet. Carefully remove *and retain* hardware from door hinges (case side). Set door aside.
2. Slide the unit back until the front of the bezel (control panel) is at least 3 inches from edge of bench top.

Replacing Circulating Fan Motor (cont.)

3. Prop up the front of the incubator by placing a shim under each front foot. Use shims between 1½ and 2 inches in thickness.
4. Remove the screws securing bezel from bottom of the incubator.
5. Grasp bezel and pull top outward. Bezel will disengage from fascia. Lay bezel aside on bench top.
6. Remove the outer chamber door and glass door.
7. Remove the two screws that secure the plenum in place, then remove the plenum.
8. Remove the six screws that secure the heater cover. Remove the cover by lifting and sliding it forward. It may be necessary to use a flat-blade screwdriver to assist in lifting the cover upward. Set heater cover aside.

Note Carefully remove the temperature sensor from heater cover before removing the cover. ▲

9. Using an Allen wrench, loosen set-screw holding the fan wheel onto the motor shaft. Observe the shaft has a flat side to prevent the set-screw from turning on the shaft. Remove the gasket cover and gasket through which the motor shaft protrudes.
10. Locate the two electrical leads from the fan motor. Remove the leads from the push-on terminal strip located in the front of the oven bezel.
11. Lay the incubator on its back with the bottom facing forward.
12. Detach the controller housing (incubator bottom) by removing the eight screws which fasten it to the cabinet. Two screws are located on each side of the incubator and four on the bottom.
13. Locate the two access holes for the motor mounting nuts located in the floor, in front of and in back of the motor shaft.
14. Push an 11/32-in nut driver through the front access hole, gently pushing aside the insulation until the nut driver reaches the front motor mounting nut.
15. Remove front nut and washer, then repeat process using back access hole to remove back motor mounting nut and washer.
16. Remove the fan motor by sliding it out.
17. Install replacement fan motor by generally reversing the steps above.

Replacing the Controller

To replace a defective controller, proceed as follows:

1. Disconnect power cord from the electrical outlet. Carefully remove *and retain* hardware from door hinges (case side). Set door aside.
2. Slide the unit back until the front of the bezel (control panel) is at least 3 inches from edge of bench top.
3. Prop up the front of the incubator by placing a shim under each front foot. Use shims between 1½ and 2 inches in thickness.
4. Remove the screws securing bezel from bottom of the incubator.
5. Grasp bezel and pull top outward. Bezel will disengage from fascia. Lay bezel aside on bench top.
6. Locate terminal blocks on controller, remove all wires connected to controller. Note color and location of wires.
7. Remove four screws that hold controller to bezel, then remove old controller.
8. Install new replacement controller and reattach wires previously removed.
9. Check wiring connections against schematic, making sure that the line power wiring is attached to the proper terminal, i.e. 120V or 230V.
10. Check switch DS 1 setting: Switches A and B should be OFF.

Replacing the Solid State Relay

To replace a defective solid state relay, proceed as follows:

1. Disconnect power cord from the electrical outlet. Carefully remove *and retain* hardware from door hinges (case side). Set door aside.
2. Slide the unit back until the front of the bezel (control panel) is at least 3 inches from edge of bench top.
3. Prop up the front of the incubator by placing a shim under each front foot. Use shims between 1½ and 2 inches in thickness.
4. Remove the screws securing bezel from bottom of the incubator.
5. Grasp bezel and pull top outward. Bezel will disengage from fascia. Lay bezel aside on bench top.
6. Consult the schematic and locate the solid state relay (mounted on bezel).
7. Remove four lead wires from their screw-down terminals.

Replacing the Solid State Relay (cont.)

8. Remove two Phillips screws securing the solid state relay to the bezel.
9. Lift out the solid state relay. Put new solid state relay in place, making certain that the thin, conductive pad remains between the solid state relay and the bezel.
10. Generally reverse the steps above to reassemble incubator.

Replacing the Safety Relay

To replace a defective safety relay, proceed as follows:

1. Disconnect power cord from the electrical outlet. Carefully remove *and retain* hardware from door hinges (case side). Set door aside.
2. Slide the unit back until the front of the bezel (control panel) is at least 3 inches from edge of bench top.
3. Prop up the front of the incubator by placing a shim under each front foot. Use shims between 1½ and 2 inches in thickness.
4. Remove the screws securing bezel from bottom of the incubator.
5. Grasp bezel and pull top outward. Bezel will disengage from fascia. Lay bezel aside on bench top.
6. Consult the schematic and locate the safety relay (mounted on bezel).
7. Remove four lead wires from their push-on terminals.
8. Remove two Phillips screws which mount the safety relay to the bezel.
9. Lift out the safety relay.
10. Generally reverse the steps above to install the replacement safety relay and reassemble incubator.

Replacing the Control Thermocouple

To replace a defective control thermocouple, proceed as follows:

1. Disconnect power cord from the electrical outlet. Carefully remove *and retain* hardware from door hinges (case side). Set door aside.
2. Slide the unit back until the front of the bezel (control panel) is at least 3 inches from edge of bench top.
3. Prop up the front of the incubator by placing a shim under each front foot. Use shims between 1½ and 2 inches in thickness.

Replacing the Control Thermocouple (cont.)

4. Remove the screws securing bezel from bottom of the incubator.
5. Grasp bezel and pull top outward. Bezel will disengage from fascia. Lay bezel aside on bench top.
6. Locate the thermocouple connections on the controller.
7. Remove the thermocouple wires by loosening two securing screws.
8. The Small units have the thermocouple located on the roof of the chamber, locate clip which holds thermocouple in place. Remove thermocouple from clip.

OR

On Medium and Large incubators, the control thermocouple is located under the bottom plenum. Remove the glass door and bottom plenum to access the thermocouple.

9. Pull thermocouple forward into chamber, exposing roughly a 6 inch section of the thermocouple wire.
10. Cut the thermocouple wire to remove the thermocouple sheath.
11. Securely loop together the cut end of the defective thermocouple with the two leads of the replacement thermocouple. Wrap masking tape over the length of the loops to secure them.
12. Gently pull the defective thermocouple out through the electronics compartment while guiding ("fishing") the replacement thermocouple into place.
13. Generally reverse Steps 1 through 7 to complete installation of new thermocouple and reassemble incubator.

Note Observe position in terminal for each lead. When re-connecting, be certain to observe polarity. Compare with polarity indication on controller housing. For thermocouples, the red wire is negative and yellow positive. ▲

Replacing the Glass Door

The Isotemp 600 series incubators feature a glass inner door to allow the chamber to be viewed with minimal heat loss. Should the glass door become damaged, it may be replaced by following the procedures below.

1. While holding the glass door, loosen the set screws on insides of upper and lower hinges of glass door.
2. Remove old glass door and set aside.
3. Generally reverse steps above to install replacement glass door. Adjust hinge position until gap between door and frame is roughly equal on all sides.

Caution While loosening hinge set screws, continue to grasp the glass door. When the set screws are loosened, the door is freed and will fall out if not held. ▲

Replacing the Door Handle

To replace a defective door handle, perform the steps below:

1. Remove the two mounting screws holding latch cover in place.
2. Remove the two mounting screws holding defective handle in place.
3. Mount the replacement handle using two screws.
4. Adjust bottom nut (13/16) from end of shaft.
5. Secure latch cover in place with two screws.

Adjusting Door Cam

Due to handling in shipment or to heat distortion with use, the door cam may require adjustment. To adjust the door cam, perform the following:

1. Open door and remove screws holding latch cover in place.
2. Locate nuts securing tongue on cam shaft.
3. Loosen but do not remove outside nut.
4. Adjust inside nut, one full turn clockwise draws door 1/16" closer to cabinet when door is closed.
5. Secure cam tongue in place by tightening outside nut.
6. Repeat Steps 1 thru 5 as necessary to get desired door seal.
7. Secure latch cover in place with two screws.

Section 7 Troubleshooting

This table is intended to assist in resolving incubator problems by relating symptoms to their likely cause. The service discussed below is beyond the scope of most users and should be performed by qualified and trained personnel.

Symptom	Probable Cause	Action
No power	Unit not plugged in or turned on	Plug in or turn on.
	Defective circuit breaker	Replace circuit breaker.
	Wire disconnected	Replace loose wires.
Incubator temperature erratically high	Defective control thermocouple	Replace control thermocouple.
	Defective control board	Replace control board.
Failure to heat	Set temperature less than actual temperature	Refer to Operation section
	Defective control thermocouple	Replace control thermocouple
	Poor heater connections	Tighten connections at terminal strip and/or heater.
	Defective heater element	Check heater resistance on schematic at back of manual. Replace heater unless approximately the same as schematic.
	Defective solid state relay or safety relay relay.	Refer to schematic and replace
	Defective controller	Replace controller.
Alarm LED stays on and control is higher than set temperature	Set temperature has been changed to a value less than the actual temperature minus the alarm limit.	Wait for actual temperature to cool to the set temperature. (To set plus 3° and LED will go out and EEE alarm display back to normal operation.)
	Defective controller	Replace controller
	Defective solid state relay or safety relay.	Refer to schematic and replace relay

(continued)

Symptom	Probable Cause	Action
Set Display Shows "EEE"	Alarm LED also lit	Allow incubator to cool to set point. See above.
	Alarm LED not on; Faulty or broken connections	Check thermocouple connections at rear of temperature controller.
	Defective control	Replace control if thermocouple is OK.
Temperature off from Independent thermometer	Calibration offset needs adjusted.	Begin by setting offset to 0. (See Display Offsets.)

Section 8 Replacement Parts

Note Only factory authorized components should be used for repair. ▲

Replacements for incubator parts may be ordered, by part number, from Technical Services.

Item	Part Number (ref)
Line Cord and Plug	
120V units	CRX120
240V units	CRX123
Temperature Controller	PCX131
Thermocouple	SPN 95603
Door Handle	SPN 104976
Shelf Kit (all incubators)	13-247S
Heater Assembly (HTR)	
Small and Medium 120V	SPN 95693
Small and Medium 240V	SPN 95734
Large 120V	SPN 95649
Large 240V	SPN 95735
Door Gasket	
Small units	SPN 101908
Medium units	SPN 101909
Large units	SPN 101910
Solid State Relay (SSR)	88616
Safety Relay (SI)	
120V units	SPN 95770
240V units	SPN 95787
Circuit Breaker	
Single Pole (120V)	SPN 95764
Double Pole (240V)	SPN 95766
Door Assembly	
Small units	DR2034X6
Medium units	DR2033X6
Large units	DR2032X

Section 8
Replacement Parts

Models covered in this manual		
Model number	Size	Voltage
11-690-625F	Small	120V
11-690-626F	Small	240V
11-690-637F	Medium	120V
11-690-638F	Medium	240V
11-690-650F	Large	120V
11-690-651F	Large	240V

(continued)

Item	Part Number (ref)
Circulating Fan Motor (MTR)	
120V units	SPN 95788
240V units	SPN 95789
Cooling Fan (FAN)	
120V units	FAX39
240V Units	FAX40

COMPONENT CHART FOR I600F MODELS

REFERENCE	DESCRIPTION	120V	240V
C1	POWER ENTRY MODULE	CEX421	CX421
C2	RECEPTACLE	95772	95669
EL1 (SML & MED)	ELEMENT	95693	95734
EL1 (LRG)	ELEMENT	95694	95735
F1	FUSE	FZX96	FZX96
FA1	FAN	FAX39	FAX40
MT1	MOTOR	95788	95789
PC1	PC BOARD	PCX131	PCX131
RY1	SOLID STATE RELAY	88616	88616
RY2	SAFETY RELAY	95770	95787
S1	SWITCH	95764	95786
TB1	TERMINAL BLOCK	95767	95767

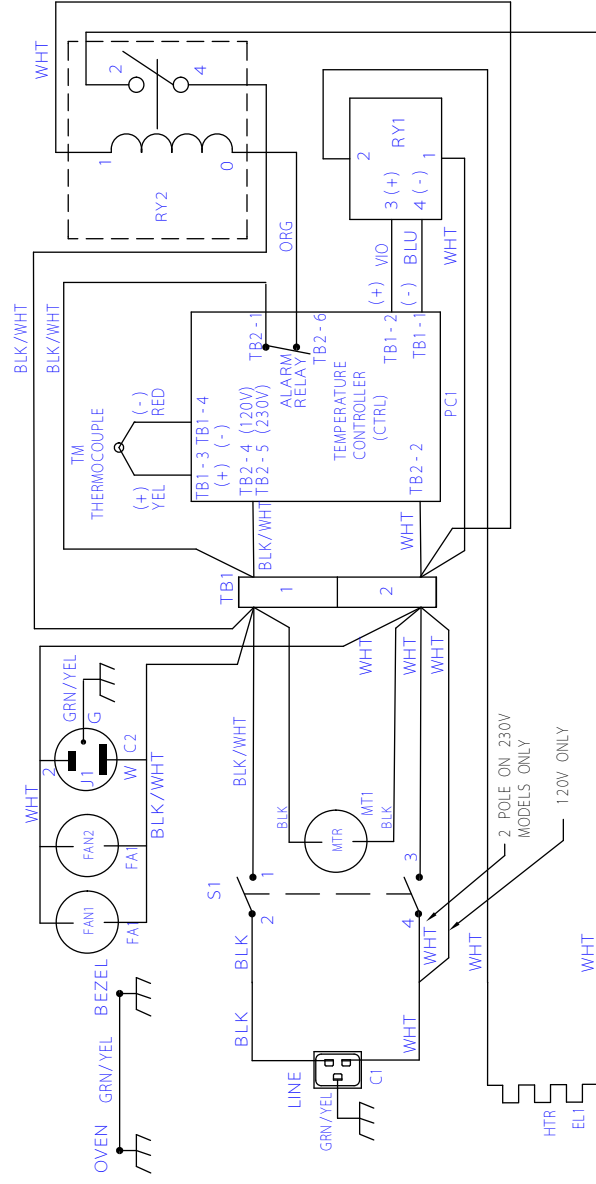

2 POLE ON 230V MODELS ONLY
120V ONLY



Fisher Scientific

For customer service, call 1-800-766-7000

To fax an order, use 1-800-926-1166

To order online: www.fishersci.com