

**Nutating Mixer Fixed Speed  
Nutating Mixer Variable Speed  
3D Platform Rotator**

Catalog Number:  
88861041  
88861042  
88861043  
88861044  
88861045  
88861046





Important before using this product, read this entire operation manual carefully. Users should follow all of the operational guidelines contained in this manual and take all necessary safety precautions while using this product. Failure to follow these guidelines could result in potentially irreparable bodily harm and/or property damage.

Caution all internal adjustments and maintenance must be performed by qualified service personnel.

Material in this manual is for information purposes only. Fisher Scientific committed to a continuing program of product development and improvement, and reserves the right to change information, such as specifications, appearance, and dimensions, described in this document without notice. Fisher Scientific makes no representations or warranties with respect to this manual. In no event shall Fisher Scientific be held liable for any damages, direct or incidental, arising out of or related to the use of this manual.

No part of this manual may be reproduced or transmitted in any form or by any means, including photocopying, recording, or using information storage and retrieval systems, for any purpose other than the purchaser's own use, without the express written permission of the manufacture.

Any other product names and services identified in this manual are trademarks or registered trademarks of their respective owners. No such use, or the use of any trade name, is intended to convey endorsement or other affiliation with Fisher Scientific.

@2015 Fisher Scientific. All rights reserved.

## Table of Contents









<b>Section 1</b>	<b>Inspection and Installation</b>	<b>1-1</b>
	Packing List	1-2
	Connections	1-3
	Structure Diagram	1-4
<b>Section 2</b>	<b>Overview</b>	<b>2-1</b>
	Specifications	2-1
	Environmental Conditions	2-2
	Safety Instructions	2-3
	Loads and Speed	2-5
<b>Section 3</b>	<b>Operation</b>	<b>3-1</b>
	Operation of the Control Panel	3-1
	Settings	3-2
<b>Section 4</b>	<b>Safety Tips and Maintenance</b>	<b>4-1</b>
<b>Section 5</b>	<b>Troubleshooting</b>	<b>5-1</b>
<b>Section 6</b>	<b>Optional Accessories/Spare Parts</b>	<b>6-1</b>
<b>Section 7</b>	<b>Warranty</b>	<b>7-1</b>

## Section 1 Inspection and Installation

1. Inspect package and contents upon receipt of the instruments. If the package is severely damaged or if there are any missing pieces, please contact the manufacturer immediately.
2. Unpack the instrument, ensure all parts of the instrument and accessories are not missing or damaged. Make sure to take out all the components before discarding packing. If there are any missing or damaged pieces, please contact the manufacturer immediately.
3. Place the instrument on a level and firm surface to avoid vibration and noise.
4. This is the general user manual for three instruments. Please make sure to refer to the corresponding chapter for your instrument.

### 1.1 Packing List

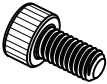
Table -1 Packing List

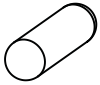
Cat. No	88861041	88861042	88861043	88861044	88861045	88861046	
Model	Nutating Mixer Fixed Speed 120V	Nutating Mixer Fixed Speed 230V	Nutating Mixer Variable Speed US	Nutating Mixer Variable Speed Interna-tional	3D Platform Rotator US plug	3D Platform Rotator Interna-tional plug	
Dimpled Rubber Mat	1	1	1	1	1	1	
General Power Adaptor	N/A	N/A	1	1	1	1	
US Plug	1	N/A	1	N/A	1	N/A	
CN Plug	N/A	1	N/A	1	N/A	1	
EU Plug	N/A	1	N/A	1	N/A	1	
UK Plug	N/A	1	N/A	1	N/A	1	
Screw for Rubber Strip	10	10	10	10	10	10	
Rubber Strips	6	6	6	6	6	6	
Fuse	2	2	N/A	N/A	N/A	N/A	

## 1.2 Connections

### Nutating Mixer Fixed Speed

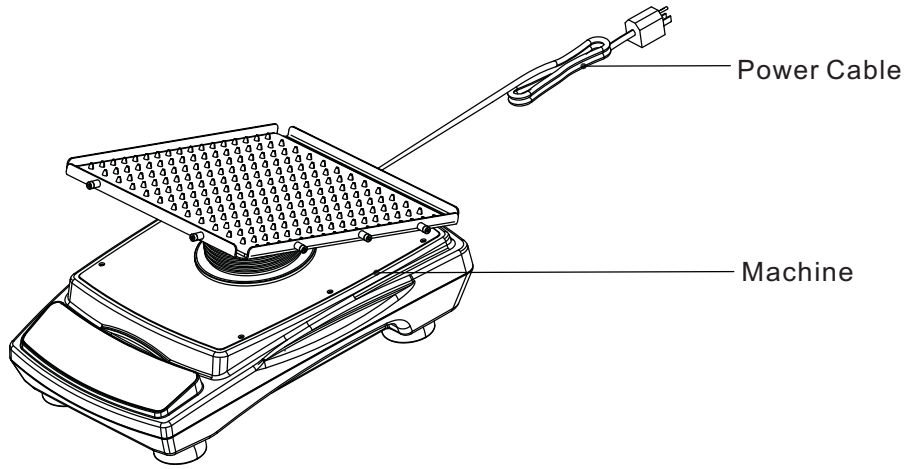

### Nutating Mixer Variable Speed/3D Platform Rotator

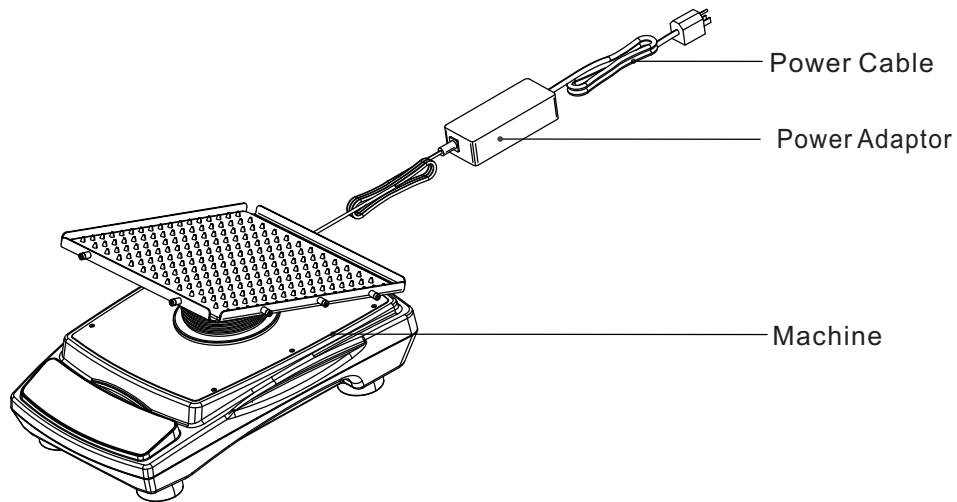

## 1.3 Structure Diagram

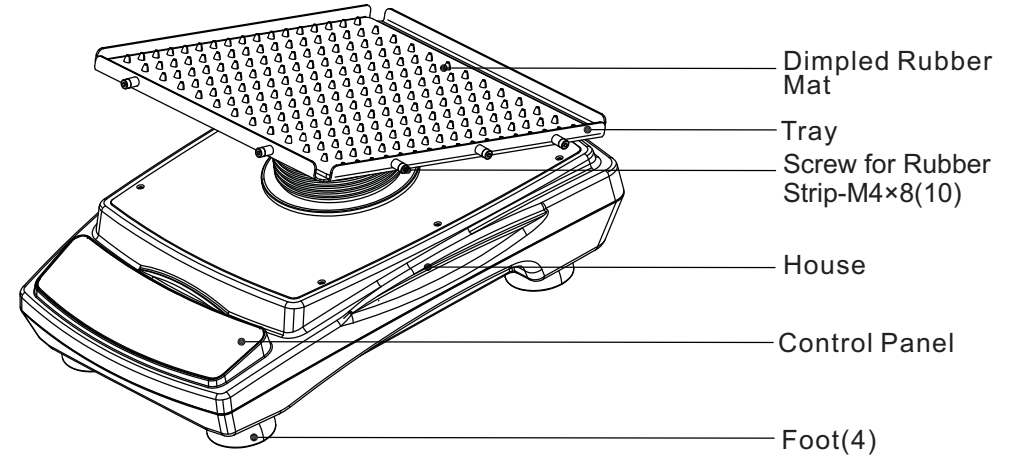

## Section 2 Overview

### 2.1 Specifications

#### Rotation Speed

Product Name	Nutating Mixer Fixed Speed		Nutating Mixer Variable Speed		3D Platform Rotator	
Cat. NO.	88861041	88861042	88861043	88861044	88861045	88861046
Speed Range	24rpm	20rpm	2 to 60rpm		2 to 80rpm	
Display Mode			LED			
Display Accuracy			1 rpm			
Speed Accuracy	±1rpm					

#### Angle

Product Name	Nutating Mixer Fixed Speed		Nutating Mixer Variable Speed		3D Platform Rotator	
Tilt Angle	20°				7°	
Tilt Angle Accuracy	±1°					
Rotation Angle	0 to 360°					

Note: Maximum speed/tilt angle may vary with heavy or unbalanced loads.

#### Load

Maximum Load (Centered on tray)	0.8kg
---------------------------------	-------

#### Time

Product Name	Nutating Mixer Fixed Speed		Nutating Mixer Variable Speed		3D Platform Rotator	
Timer Range			1min to 99h59min			
Display Mode			LED			

#### Power Supply

Product Name	Nutating Mixer Fixed Speed		Nutating Mixer Variable Speed		3D Platform Rotator	
Cat. NO.	88861041	88861042	88861043	88861044	88861045	88861046
Requirement	110V, 60z, 0.1A	220V, 50Hz, 0.05A	100~240V, 50Hz/60Hz, 1A		100~240V, 50Hz/60Hz, 0.8A	

#### Size

Product Name	Nutating Mixer Fixed Speed	Nutating Mixer Variable Speed	3D Platform Rotator
Overall Dimensions	415×293×273mm (16.3×11.6×10.7in.)		415×295×170mm (16.3×11.6×6.7in.)
Tray Dimensions	306×266mm(12.0×10.5in.)		
Package Dimensions	536×501×346mm(21.1×19.7×13.6in.)		

#### Weight

Product Name	Nutating Mixer Fixed Speed	Nutating Mixer Variable Speed	3D Platform Rotator
Net Weight	5.9kg(13lb)	7.4kg(16.3lb)	7.3kg(16.1lb)
Gross Weight	8.6kg(18.9lb)	9.4kg(20.7lb)	9.3kg(20.5lb)

#### Others

Noise Level	< 55 dB with no load when ambient noise is 45 dB
Certificate	ROHS, WEEE, cCSAus, CE Mark

### 2.2 Environmental Conditions

Application Environmental Conditions: indoor use

Temperature	5 to 40 °C (41 to 104 °F)
Humidity	20% to 85%,
Altitude	≤2,000 m
Voltage Fluctuation	±10% of the nominal voltage

Storage Environmental Conditions

Temperature	0 to 60 °C (36 to 124 °F)
Humidity	20% to 90%, non-condensing

## 2.3 Safety Instructions

Please read the entire instruction manual before operating the Nutating Mixer/3D Platform Rotator.

**WARNING DO NOT** use the Nutating Mixer/3D Platform Rotator in a hazardous atmosphere or with hazardous materials for which the unit was not designed. Also, the user should be aware that the protection provided by the equipment may be impaired if accessories used are not provided or recommended by the manufacturer, or are used in a manner not specified by the manufacturer.

**CAUTION !** To avoid electrical shock, completely cut off power to the unit by disconnecting the power cord from the unit or unplug from the wall outlet.

Disconnect unit from the power supply prior to maintenance and service. Any spills should be removed promptly. Biohazard spills should be cleaned using approved liquid promptly. Solvent spills are a fire hazard. Stop the unit immediately, and **DO NOT** operate until clean up is complete and vapors have dissipated.

**DO NOT** immerse the unit for cleaning.

**DO NOT** operate the unit if it shows signs of electrical or mechanical damage.

### Position of Loads

Place the loads in the recommended positions below:

1. Place load at the center of the tray
2. Place loads symmetrically around the center of the tray
3. Make sure to use rubber strips to fasten containers onto the tray

Centered Placement



### Symmetrical Placement

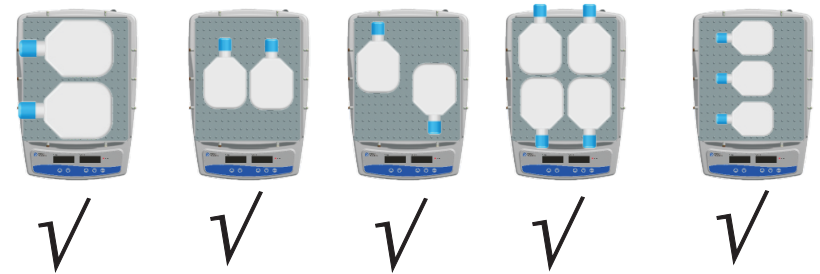

### Asymmetrical Placement

#### Cornered Placement



#### Sided Placement



### Other Placement

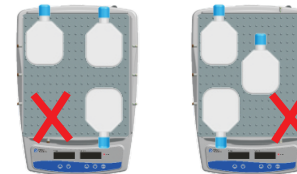

**WARNING** Asymmetric loading or unloading may affect the normal operation of the instrument and may even cause unpredictable damage.

## 2.4 Loads and Speed

### Nutating Mixer Variable Speed

Cell Culture Flask Specification(cm2)	≤Capacity (ml)	Maximum Speed (rpm)
25	30/40	60
75	225	60
150	450	60
175	600	60
225	800	60

### 3D Platform Rotator

Cell Culture Flask Specification(cm2)	≤Capacity (ml)	Maximum Speed (rpm)
25	30/40	80
75	225	80
150	450	80
175	600	80
225	800	80

**Warning:** The rotation speed is inversely proportional to the load. When the instrument is in use, it is recommended to adjust the rotation speed from low to high, step by step and run the machine at an appropriate speed to avoid accidental spillage of liquids.

For safety, please always using rubber strip to hold samples in place.

## Section 3 Operation

This Chapter covers introduction of the control panel and its operation.

### 3.1 Operations of the Control Panel

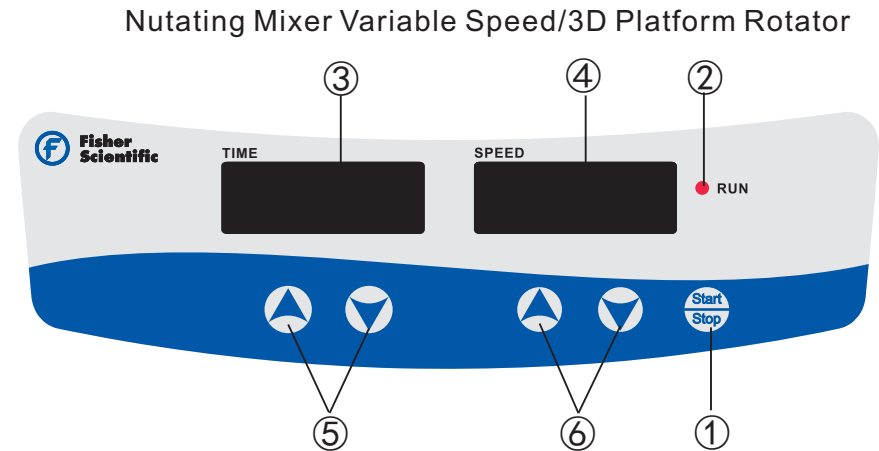

The front panel of the Nutating Mixer Variable Speed/3D Platform Rotator contains all the controls needed to operate the unit.

1. Start/Stop button: Start or stop the instrument.
2. RUN indicator light: The light is on when the instrument is running and off when the instrument is in standby.
3. TIME display window: The window shows cumulative time (in continuous mode) or remaining time (in timer mode). The range of time displayed is 0 to 99 hours and 59 minutes. The accuracy is 1 minute.
4. SPEED display window: The window shows set speed (when the instrument is in standby) or current speed (when the instrument is running).
5. Set Time Buttons: UP/DOWN Arrow buttons are used to increase/decrease the set time of the instrument.
6. Set Speed Buttons: UP/DOWN Arrow buttons are used to increase/decrease the set speed of the instrument.

### Nutating Mixer Fixed Speed



1. RUN indicator light: The light is on when the instrument is running.

#### Preparation

1. Connect all the components according to the figures shown on page 1-3 of this manual. Use grounded power outlet.
2. Press power button on the back right side of the instrument and put it to the “|” state and then the instrument is in standby.

### 3.2 Settings

#### Nutating Mixer Variable Speed/3D Platform Rotator

##### Time Settings

##### 1. Continuous mode

Press the “▲” or “▼” arrow button below the TIME display window. When the number shown on the display window starts flashing, press “▼” arrow button to decrease the time to 00:00 and then release the button. The time setting is finished after the number shown on the display window has flashed twice.

##### 2. Timer mode

Press the “▲” or “▼” arrow button below the TIME display window. When the number shown on the display window starts flashing, press “▲” or “▼” arrow button to increase or decrease the time value. Release the button when the time shown on the display window reaches the set value. The time setting is finished after the number shown on the display window has flashed twice.

#### Speed Settings

Press the “▲” or “▼” arrow button below the SPEED display window. When the number shown on the display window starts flashing, press “▲” or “▼” arrow button to increase or decrease the speed value. Release the button when the speed shown on the display window reaches the set value. The speed setting is finished after the number shown on the display window has flashed twice.

**Note:** press the “▲” or “▼” arrow button for a longer time to accelerate the setting.

#### Run and Stop

##### 1. Continuous Mode

Press “Start/Stop” button and the instrument will start running with the specified settings and the RUN indicator light will be on. The TIME display window will show the cumulative time and the SPEED display window will show the current speed. Press “Start/Stop” button again and the instrument will slow down until it stops. The instrument will then be in standby and the two display windows will show the set values.

##### 2. Timer Mode

Press “Start/Stop” button the instrument will start running with the specified settings and the RUN indicator light will be on. The TIME display window will show the remaining time and the SPEED display window will show the current speed. Press “Start/Stop” button again and the instrument will slow down until it stops. The instrument will then be in standby and the two display windows will show the set values.

#### Nutating Mixer Fixed Speed

Turn the power switch to “|” position. The RUN indicator light will be on and the instrument will start rotating at the fixed speed.



### Finish Operation

After the operation is finished, please press the power switch at the back right side the instrument and put it into the “O” state. Unplug the instrument and store the instrument according to the storage guide.

### Alarm System

When the normal operation is obstructed or stopped by malfunctioning, the instrument will stop running automatically within 2 minutes and the alarm will sound.

### Power Recovery

If the power supply is cut off suddenly while the instrument is in operation, the unit will automatically run at the previously set parameter upon power restoration. The display window will flash. Press any button to stop flashing.

## Section 4 Safety Tips and Maintenance

### Safety Tips

1. Use independent power supply.
2. Check if the local power supply voltage is suitable for use.
3. Do not drag the power supply cable when unplugging.
4. Do not use non-specified power cable nor damage cable.
5. Service should only be performed by a qualified professional.
6. The power supply must be unplugged under the following situations:
  - a. when the unit is moved
  - b. when the electrical cabinet or the moving component is opened
  - c. when the equipment is malfunctioning
  - d. when the equipment is not in use

### Maintenance

- a. This instrument uses a high-accuracy motor. It is maintenance free and has a long service time, high quality, and low noise level.
- b. Surfaces can be cleaned with a mild detergent and water. Liquid is not allowed inside the dust cover.
- c. Two fuses are installed inside the power socket at the back of the Nutating Mixer Fixed Speed (One is for work and the other is for backup). The installation of the fuses is shown in the figure below:



**Warning:** Avoid dripping detergent or water into the instrument during cleaning.

### Clean Spill

If accidental spillage of liquids caused by mishandling or contained break-age occurs on the surface of the instrument, please shut down the instrument and clean up the liquid immediately.

If the liquid has already spilled into the unit, please cut off the power supply first and immediately clean up the liquid at the surface of the instrument. Then place the instrument in a ventilated and dry environment for 24 hours before reuse. If the instrument is still not functioning after drying for 24 hours, please contact the manufacturer.



**Warning:** Disassembling/Assembling without a qualified professional's guidance may cause malfunctioning of the instrument.

## Section 5 Troubleshooting

Please refer to the following table to troubleshoot if any malfunction occurs. If the problem still exists, contact your local sales representative.

Error	Cause	Solution
Cannot start machine, LED display window off	Power disconnected	Connect the power
	Power adaptor failure	Replace power adaptor
	Switch off	Switch on
No shaking of the tray	Electrical malfunction	Contact Fisher Scientific
	Mechanical malfunction	Contact Fisher Scientific
	Over-weighted or unbalanced load	Adjust the weight and position of load, decrease rotation speed
Loud noise	Load moving	Change Dimpled Rubber Mat or fasten load
	Tray loose	Fasten fixing screws on the tray
	House loose	Fasten fixing screws at the House
Other	Keep record for maintenance	

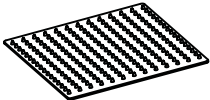
## Section 6 Optional Accessories/ Spare Parts

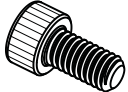
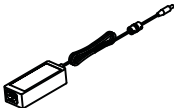
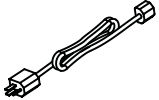
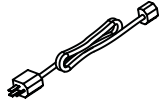
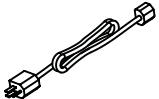
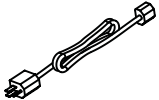
Description	Cat. No.	Dimensions	Figure
Dimpled Rubber Mat	88861198	298×258mm	
Rubber Strips	88861178	180×7mm (6pcs/pack)	
Screw for Rubber Strip	88861199	M4×8 (8pcs/pack)	
General Power Adaptor	88861128	AC 100~240V, 50/60HZ	
US Plug	88861129	125VAC, 10A, 1.8m	
CN Plug	88861130	250VAC, 10A, 1.8m	
EU Plug	88861131	250VAC, 10A, 1.8m	
UK Plug	88861132	250VAC, 10A, 1.8m	

## Section 7 Warranty

When used in laboratory conditions and according to these operation instructions and maintenance, this product is warranted for 24 months against defective materials or workmanship. The 24 month warranty period begins from the delivery date of this product.

For product quality or performance issues, contact Fisher Scientific Customer Service.