

If you have problems

If you have problems using the unit, follow these general procedures to track down the cause from the symptoms you are experiencing. If an error message appears on the display, refer to the specific error in this chart.

If the problem is not resolved using the table below, Contact technical support at 1-800-926-0505 .

If you are having this	This might be the cause
No power indication	Unit not plugged in; no power at the outlet; incorrect power (make sure outlet matches label on back of unit); defective power cord; defective power switch or fuse (s). (call Technical Support).
No heating	Setpoint or backup not set properly; defective heater or controller (call Technical Support).
Always heating; temperature greater than	Defective controller (call Technical Support).
Very slow heating of samples	Empty tank or extremely low liquid level in tank (add liquid to the tank to improve heating).
Unit heating up slower than normal	Defective controller (call Technical Support).
Alarm light on constantly	Setpoint or backup not set properly; defective primary controller (call Technical Support).
Display not correct	Temperature F or C set in error; temperature not calibrated (perform calibration procedure with thermometer); defective controller (call Technical Support).
Erratic operation	Broken internal electrical connection; defective heater or controller (call Technical Support).
Error message: E1	Failure of temperature sensor or controller (call Technical Support).
Error message: E2	Failure of controller (call Technical Support).
Display shows LLLL at power-up.	Wrong voltage, Controller not set up properly (call Technical Support).

Specifications

These are nominal specifications. Fisher reserves the right to change specifications or designs at any time without incurring obligation.

Power requirements	120 VAC or 230 VAC ± 10%, 50 or 60 Hz
Ambient conditions	+4°C to +35°C, up to 75% relative humidity
Temperature range	Cover open: Ambient to 60 °C Cover closed: Ambient to 100°C
Control	±0.1°C between ambient and 100°C
Uniformity	±0.24°C at 37°C
Stability	±0.5°C at 37°C
*Max. Altitude	2000m
*Over Voltage Category	II (IEC 664)
*Pollution Degree	2 (IEC 664)
*CE Products meet the relevant EC harmonized standards for safety (IEC1010-1/EN61010 and EMC (EN55014, EN55104, EN61000-4-2, -4-4, -4-6, -4-11 and ENV50140)	

*Applies to 230V units only

Replacement Parts

WARNING: To avoid electrical shock, always disconnect from power supply before maintenance and servicing. Refer servicing to qualified personnel.

Item	Part No.
Cover, 2 liter	Plastic Lid SPN102304 Stainless Steel Lid 15-462-32
Cover, 2 liter shallow and 5 liter	Plastic Lid SPN102305 Stainless Steel Lid 15-462-33
Cover, 10 liter	Plastic Lid SPN102306 Stainless Steel Lid 15-462-34
Cover, 20 and 28 liter	Plastic Lid SPN102307 Stainless Steel Lid 15-462-35
Hinge, lid (for 2 liter)	SPN102383
Hinge, rim (for 2 liter)	SPN102384
Hinge, lid (for all except 2 liter)	SPN102386
Hinge, rim 28L and Dual Models)	SPN102387
Hinge, rim (for 2S, 5, 10 & 20 liter)	SPN102459
Clip, thermometer (for 2L shallow)	SPN102423
Clip, thermometer (all except 2LS)	SPN102424
Microbicide, 8 oz. Bottle	13-641-337
Pump, Siphon	SPN102391
Controller PC board (120V)	SPN102419
Controller PC Board (230V)	SPN104068
Display PC board	SPN102420
Controller, safety	SPN102499
Sensor, RTD	SPN102331
Diffuser Tray, 2 liter	SPN102352
Diffuser Tray, 2L shallow or 5 liter	SPN102353
Diffuser Tray, 10 liter	SPN102354
Diffuser Tray, 20 or 28 liter	SPN102355
Fuse, Type 3AG 1.25x.25, 10 Amp	SPN45920
Fuse, 5x20mm, F5A 250V	SPN102487

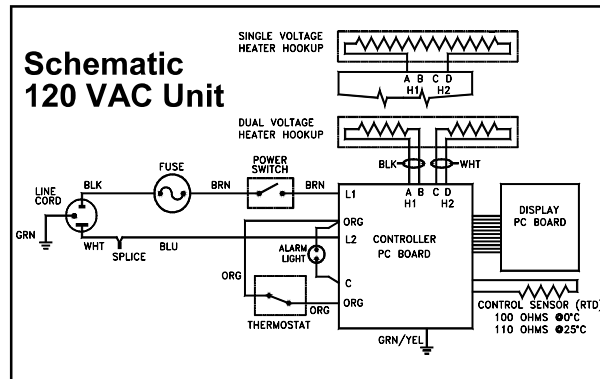

Note: The Stainless steel water bath cover was designed as an alternate to the see through Plastic (polycarbonate) cover. No material is impervious to attack by all chemicals. The Stainless lids are made of a good quality 304 stainless steel which is the same as the tank. Clean with mild soap and water. Rinse with clear tap water.

