

MultiTherm Shaker

Operations Manual

Item: H5000-H and H5000-HC



Benchmark Scientific 

Forward

Thank you for purchasing the MultiTherm™ Shaker. This operations manual contains instructions for the proper care and operation of this Instrument. Prior to operating this instrument, please read this manual carefully.

Prior to operating the instrument for the first time, please check the package to ensure that the Instrument and all accessories have been included and are free from any damage in transit. In the event that any damage is found (or items are missing), Please contact Benchmark Scientific at +1 908 769 5555,

Safety Warnings and Guidelines

1. Important operation information:

Please read this manual carefully prior to any attempt to operate the Instrument.



Read the manual prior to power up of the instrument. Read the guidelines and directions below and be familiar with all safety warnings and guidelines.

2. Security:

The operation, maintenance and repair of the Instrument must comply with the basic guidelines and warnings stated below. Failure to comply may jeopardize the instrument life, warranty coverage and user safety.



Use this product indoors. Do not operate in a damp or wet environment.



Do not attempt to disassemble or repair the Instrument by yourself. Disassembly will void the warranty. If there is a malfunction contact your supplier for repair service.



The three pin plug supplied with the instrument is a safety device that should be matched with a suitable grounded outlet. Do not attempt to defeat the three pin plug or its grounded function.



During normal operation, the temperature of metal block will become very hot. Do not touch the block during or within 30 minutes of operation.



Close all test tube lids before inserting into the block. Do not allow liquids to spill into the block or any part of the instrument.



Before connectivity to a power source, check that the voltage listed on the serial number label (on the bottom or back side of the unit) to ensure that it matches the voltage available in your area.



Be sure to install the Instrument in a cool, dry location away from any direct sunlight or strong light sources. Additionally the instrument should be kept away from corrosive gas, magnetic fields and dusty environments. Keep the instrument and the air vents at least 4 inches from walls, other instruments or any obstructions.

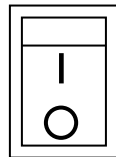

The Main power switch is on the rear of the device, push “I” to power on the instrument, and push “O” to power off.



Shut the power off when you finish your work. Unplug the machine if it will not be operated for a long time period and cover it with a cloth or plastic paper for protection from dust particles



Immediately unplug the instrument from the outlet and contact the vendor in the event of:

- Fire or smoke.
- Liquid has gotten into the Instrument;
- Abnormal operation: such as abnormal sound or smell.
- Instrument has been dropped or outer case is damaged.
- The function has visibly changed.

3. Maintenance of the Instrument

The block wells should be cleaned by a cloth dampened with alcohol to ensure good heat transmission between the block and the test tube. If there are marks, dirt or stains on the instrument exterior, clean them with a cloth dampened with water or a mild detergent solution.



Always shut the power off when cleaning the Instrument.
When cleaning the block wells, do not apply the cleaning liquid directly to the block, use a dampened cloth. Do not use strong or corrosive cleaning agents.

Contents

Chapter 1: Introduction	5
Chapter 2: Specifications	5
1. Normal operating conditions	5
2. Technical data	6
Chapter 3: Preparations	8
1. Physical Description	8
2. Keyboard and Display panel	9
3. Key Functions	10
Chapter 4: Operation Guide	11
1. Single Temperature, Speed and Time setting	11
2. Sequence Link Setting	12
3. Disabling the Temperature Speed or Time	12
4. Pulse	13
5. Temperature Calibration	13
6. Changing the Block	16
Chapter 5: Failure analysis and troubleshooting	17

Chapter 1: Introduction

The MultiTherm shaker is an ideal instrument for intensive mixing of samples under temperature regulated conditions.

Mixing and temperature control modes can be used both simultaneously and independently i.e, the device can work as shaker and/or as an incubator. The base instrument can be used with a variety of different blocks. The instrument is applicable for DNA analysis, extraction of lipids and other cell components, DNA library creation, PCR amplification, pre-denaturation in electrophoresis, serum solidification etc.

Features of this product as follows:

1. Because it can be used with various optional mixing blocks, the instrument can adapt to different tubes and plates to accommodate many experimental needs. Customized blocks are available to suit your specific demands.
2. LCD display
3. Simultaneous display of set and actual time, temperature and speed
4. Over-heat protection system ensures safety & reliability
5. Temperature can be calibrated to meet the user's needs
6. End-of-run signal alerts the user of cycle completion

Chapter 2: Specifications

1. Normal operating conditions

Ambient temperature: 5°C ~30°C / Relative humidity: ≤70%

Note: Do not attempt to operate the instrument at temperatures or humidity levels outside of this range.

2. Technical data, H5000-H

Model Parameter	H5000-H	
Mixing rate*	200~1500 rpm	
Orbit	3mm	
Temperature setting range	5°C to 100°C	
Temperature control range*	Ambient +5°C to 100°C	
Timing range	1min to 99h59min	
Accuracy of the temperature	≤1.0°C	
Heating time	≤15min (from 20°C to 100°C)	
Cooling time	N/A	
Block Configuration	A-BLOCK: 96 well Plate or 96 x 0.2ml; B-BLOCK: 0.5ml x 54 C-BLOCK: 1.5ml x 35 D-BLOCK: 2.0ml x 35 E-BLOCK: 15ml x 12 F-BLOCK: 12mm x 24 G-BLOCK: 50ml x 6	
Power Supply	AC100-120~ 2.5A 50-60Hz	AC200-240~ 1.5A 50-60Hz
Fuse	250V 4.0A Φ5×20mm	250V 3.0A Φ5×20mm
Dimension (mm)	300(D)×2 12(W)×210(H)	
Net weight (kg)	8.5	

*Specification is valid when used with “standard” blocks only. Larger blocks (Blocks E, F and G) have different speed and temperature specifications.

Technical data, H5000-HC

Model Parameter	H5000-HC	
Mixing rate*	200~1500 rpm	
Orbit	3mm	
Temperature setting range	0° to 100°C	
Temperature control range*	0° to 100° at Room temp. ≤20°C 4° to 100° at Room temp. ≤25°C 10° to 100° at Room temp. ≤30°C	
Timing range	1min ~ 99h59min	
Accuracy of the temperature	≤1.0°C	
Heating time	≤15min (from 20°C to 100°C)	
Cooling time	≤30min from room temp. to -20°C below room temp.	
Block Configuration	A-BLOCK: 96 well Plate or 96 x 0.2ml; B-BLOCK: 0.5ml x 54 C-BLOCK: 1.5ml x 35 D-BLOCK: 2.0ml x 35 E-BLOCK: 15ml x 12 F-BLOCK: 12mm x 24 G-BLOCK: 50ml x 6	
Power Supply	AC100-120 ~ 2.5A 50-60Hz	AC200-240 ~ 1.5A 50-60Hz
Fuse	250V 4.0A Φ5×20mm	250V 3.0A Φ5×20mm
Dimension (mm)	300(D)×212(W)×210(H)	
Net weight (kg)	8.5	

*Specification is valid when used with “standard” blocks only. Larger blocks (Blocks E, F and G) have different speed and temperature specifications.

Chapter 3: Preparations

This chapter provides a physical description, location of controls, function of individual keys, as well as some preparations before the initial power-on. You should be familiar with this chapter before the Thermo Shaker is first operated.

1. Physical Description

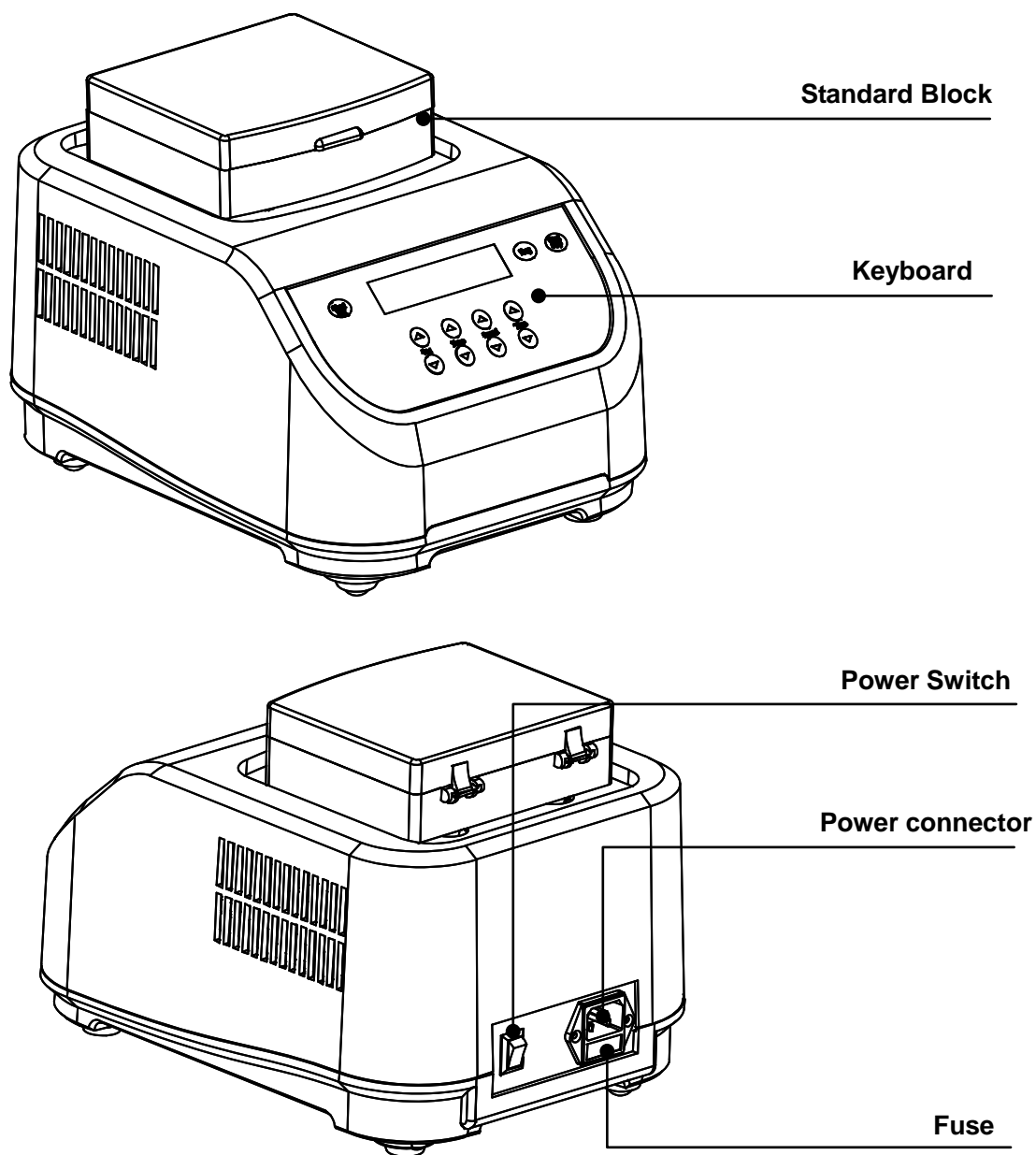

2. Keyboard and Display panel

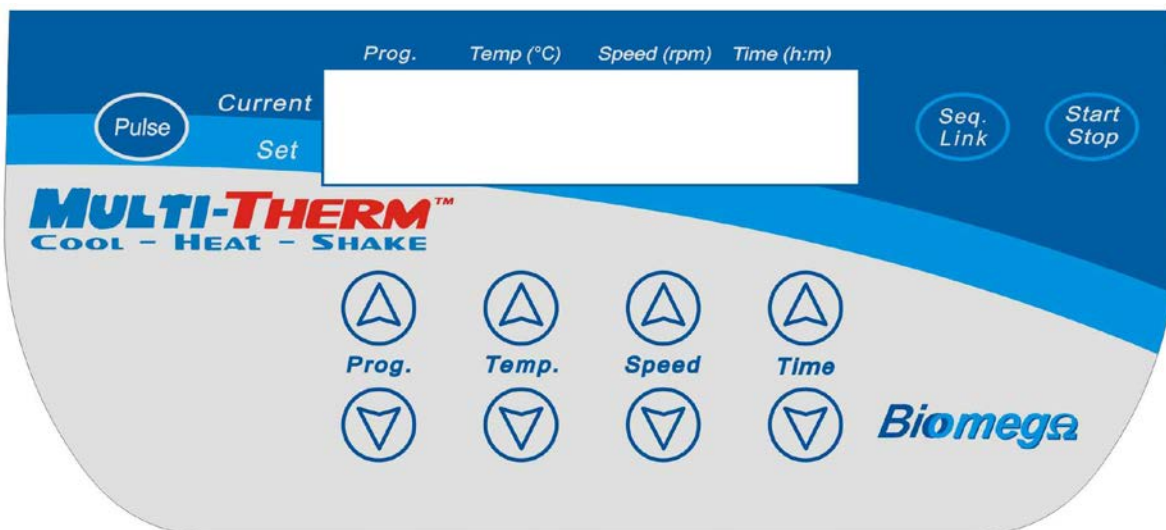

Display Panel:

Current program	Current temperature	Current speed	Remaining time
P1	100.0	1200	10:30
P1	100.0	1200	15:00
Selected program	Selected temperature	Selected speed	Selected time

3. Key Functions

- Prog.** ▲ ▼ Program Selection Keys: Use the up and down keys to choose the desired program (P1, P2, P3, P4 or P5).
- Temp.** ▲ ▼ Temperature Selection Keys: Press “▲” or “▼” to select the desired temperature in increments of 1°C. (To quickly scroll to the desired temperature, press and hold the “▲” or “▼” keys.)
- Speed** ▲ ▼ Speed Selection Keys: Press “▲” or “▼” to select the desired mixing speed in increments of 10rpm. (To quickly scroll to the desired mixing speed, press and hold the “▲” or “▼” keys.)
- Time** ▲ ▼ Time Selection Keys: Press “▲” or “▼” to select the desired run time. (To quickly scroll to the desired time, press and hold the “▲” or “▼” keys.)
- Seq. Link** Sequence Link Key. Press the “Seq. Link” key to run consecutive programs. Choose from P1 to P2, P1 to P3, P1 to P4, or P1 to P5 to run up to five consecutive programs.
(The Sequence link function is only available on the H5000-HC.)
- Pulse** The device mixes at the speed shown on the display for as long as the Pulse key is held down. The time is counted in seconds until 999 Seconds has expired.
- Start/Stop** Start/Stop Key. press this key to start or stop the program. Press briefly to start. Press and hold to stop.

Chapter 4: Operation Guide

1. Single temperature, speed and time setting

a) Following power up, the unit beeps once and the LCD will display “System Testing”. After approx. 5 seconds, the current and selected settings appear on the display and the instrument is ready for use.

b) The current block temperature is displayed on the LCD, for example, 30.0 along with the current mixing speed, 0 rpm and the current time, 00:00. The set or selected temperature shows 37.0, which is the initial preset temperature. The initial preset mixing speed and time are also displayed at 1000rpm and 10:00 respectively.

c) Five programs are available for storage. By pressing the “△” or “▽” Prog. keys, choose the desired program, P1, P2, P3, P4 or P5.

By pressing the “△” or “▽” Temp. keys, the value of the selected temperature is adjusted in increments of 0.1°C on the display window.

By pressing the “△” or “▽” Speed keys, the value of the selected mixing speed is adjusted in increments of 10 rpm.

By pressing the “△” or “▽” time keys, the value of the selected run time is adjusted in increments of 1 min.

System-Testing
.....

Prog ▲ ▼

P1 30.0 0 00:00
P1 37.0 1000 10:00

Temp ▲ ▼

P1 30.0 0 00:00
P1 40.0 1000 10:00

Speed ▲ ▼

P1 30.0 0 00:00
P1 40.0 1200 10:00

Time ▲ ▼

P1 30.0 0 00:00
P1 40.0 1200 2:00

NOTE: Press and hold the “ Δ ” or “ ∇ ” adjustment keys to quickly scroll through the available temperature, speed and time range

Press the **Star/Stop** Key to begin the cycle

2. Sequence Link Program Setting *(Available on H5000-HC only)*

a) By Pressing the “Seq. Link” Key, the user can connect up to five programs to run consecutively (P1-P2, P1-P2-P3, P1-P2-P3-P4, P1-P2-P3-P4-P5).

b) Once the Seq. Link button is pressed, the display shows the starting program “P1” and the default ending program, “P2”. To adjust the ending program, press the “ Δ ” or “ ∇ ” Prog. Keys. Once the ending program has been selected, press the Seq. Link key to finalize.

PROG to validate Star:P1 End:P2

P1 30.0 0 00:00 P14 50.0 1400 3:00

c) To begin the first program, press the “start/stop”key. The first program will run through completion. Following completion, the subsequent cycle will begin automatically.

NOTE: A program can always be stopped (cancelled) by pressing and holding the “start/stop” key.

3. Disabling the temperature, speed or time functions.

a) To deactivate the temperature control, press and hold the “ ∇ ” Temp. key until the set temp. shows “OFF”. The temperature control is now deactivated and the instrument can be used solely as a shaker/mixer.

- b) To deactivate the shaker speed, press and hold the “▽” Speed key until the set speed shows “OFF”. The shaker is now deactivated and the instrument can be used solely for temperature control.
- c) To deactivate the timer, press and hold the “▽” Time key until the set time shows “OFF”. The timer is now deactivated and the instrument will run continuously until the user presses and holds the start/stop key.

NOTE: When running consecutive programs in the Seq. Link mode, the time should not be set to “OFF” in any program.

4. Pulse

By pressing and holding the Pulse key, the instrument mixes at the selected speed for as long as the Pulse key is held down. The time is counted in seconds until 999 seconds has expired.

Pulse	is	running
600rpm		023S

5. Temperature calibration

The temperature of the Instrument has been factory adjusted and calibrated prior to being shipped. But if there is deviation between the actual temperature and the displayed temperature, the user can self-calibrate the instrument in order to correct the error.

Note: The temperature accuracy will be within $\pm 0.5^{\circ}\text{C}$.

Calibration Procedure:

- a) Verify that the ambient temperature is less than 25°C and power up the instrument. Once powered on, verify that the current temperature in display is below 25°C . If the temperature is above than 25°C , please wait for the unit to cool down to 25°C or less.
- b) Inject olefin oil into one of the cone-shaped wells, and insert a thermometer into this well. (Make sure the accuracy of the thermometer is to be within 0.1°C and that it is completely immersed into well). Heat insulation material is needed on the block to insulate it from the ambient temperature. See Fig a.:

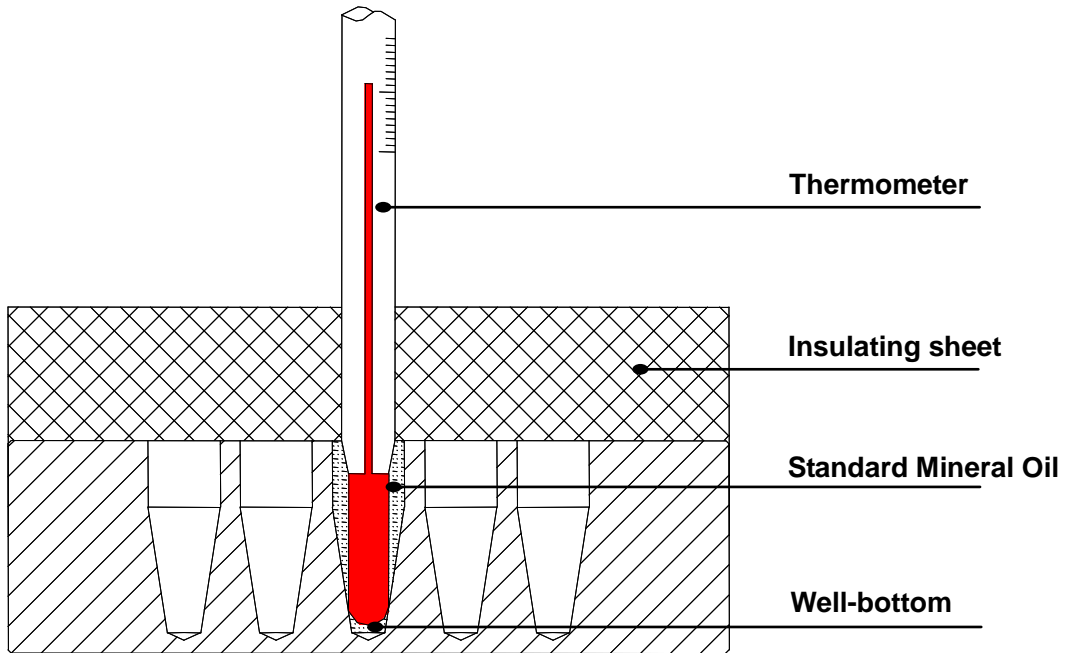

Fig. A

Notes: Please read the actual value after allowing 20 minutes constant temperature equilibration time.

To enter the temperature calibration mode, press the “ Δ ” and “ ∇ ” Prog. Keys simultaneously. The instrument begins to cool to the low calibration point.

- H5000-H
Calibration points: 40°C, 100°C

- H5000-HC
Calibration points: 10°C, 40°C, 100°C

c) After 20 minutes, read the temperature of the Thermometer (for ex. 9.8°C). Using the “ Δ ” or “ ∇ ” Temp. keys, adjust the temperature of the display to match that of the thermometer and press the “start/stop” key to confirm.

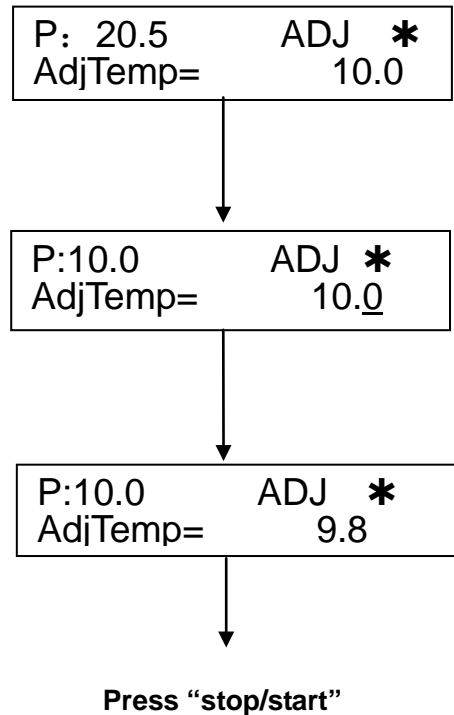

- d) Repeat the above step for the remaining temperature calibration points.

P: 40.1	ADJ *
AdjTemp=	40.0

Following the adjustment to the final calibration point, the temperature calibration of the instrument has now been completed and the displayed temperature will accurately represent the temperature of the heating block.

P: 100.0	Adj *
AdjTemp=	98.0

NOTE: During the temperature calibration, press the “△” and “▽” Prog. keys simultaneously to cancel the calibration. The system will default back to the former calibration.

6. Changing the block

- a) Open the transparent lid and use the supplied hex wrench (3mm) to remove the four screws that hold the block to the heating board.

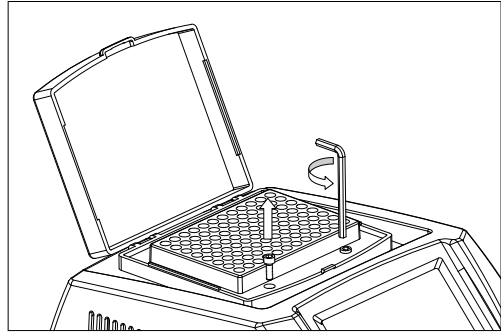

- b) Close the lid and lift the block up and away from the base unit.

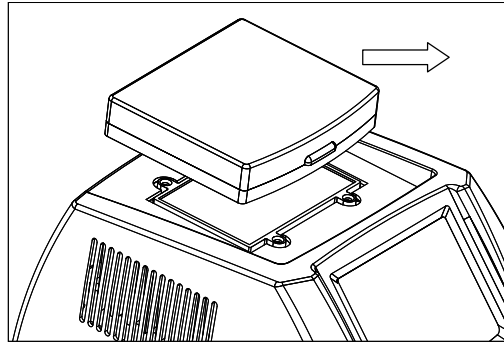

- c) Place the desired block softly on the heating platform of the base unit and carefully align the four screw holes.

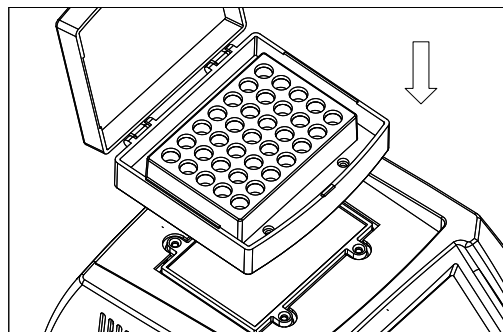

- d) Install and tighten the four screws. Do not over tighten.

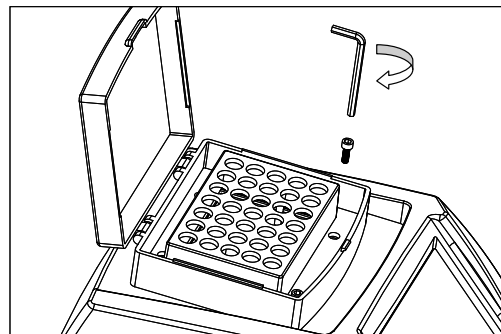

Chapter 5: Failure analysis and troubleshooting

Failure analysis and processing procedures

No.	Symptom	Possible Causes	Action
1	No display when powered up.	No power	Check the power
		Fuse failure	Exchange fuse (250V 3.0A 5X20mm)
		Broken switch	Replace the switch
		Others	Call for service
2	The actual and displayed temperatures are significantly different.	Temperature sensor failure	Call for service
3	“OPEN” in the temperature display with a short beep	Temperature sensor failure or the environmental temperature is below zero	Call for service
4	“SHORT” in the temperature display with a short beep	Temperature sensor failure or the environmental temperature is below zero	Call for service
5	No heating or cooling	Broken sensor or Broken TE module	Call for service
6	No reaction when a key is pressed	Failed film switch	Call for service

Notes

Benchmark 
Scientific

PH: 908-769-5555

EM: info@benchmarkscientific.com