

SX4750A Swinging-Bucket Rotor

Specifications

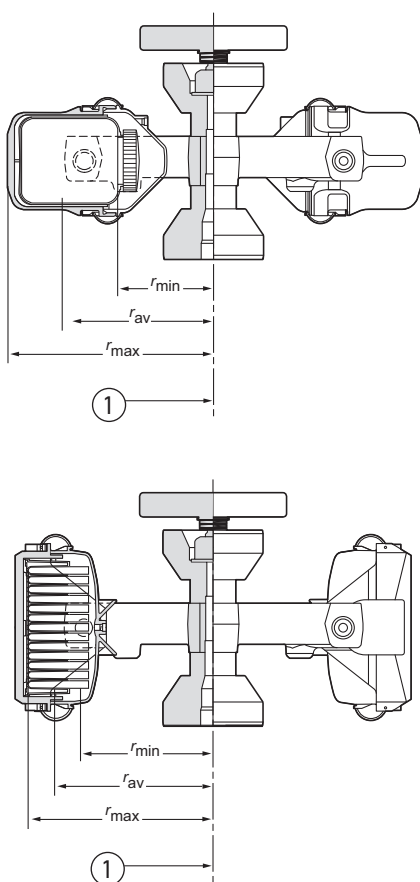

1. Axis of Rotation

Maximum speed

Allegra X-15R (tube-and-bottle buckets)	4750 RPM
Allegra X-15R (multiwell-plate carriers)	4450 RPM
Allegra X-14 series (tube-and-bottle buckets)	4300 RPM
Allegra X-14 series (multiwell-plate carriers)	4000 RPM
Allegra X-12 series (all buckets)	3750 RPM

Critical speed range^a580 to 720 RPM

Maximum solution density 1.2 g/mL

Relative Centrifugal Field^b at maximum speed

using tube-and-bottle buckets ($r_{\max} = 207.8$ mm)	$5250 \times g^c$
using multiwell-plate carriers ($r_{\max} = 183.2$ mm)	$4060 \times g^c$

Conditions requiring speed reductions see Speed Derating

Number of buckets/carriers4

Available tubes and bottles see [Table 2](#)

Maximum load allowed in each tube-and-bottle bucket at rated speed

(excluding weight of bucket and cover) 1000 grams

Maximum load allowed in each multiwell-plate carrier at rated speed (excluding weight of carrier and cover)

..... 360 grams

Total maximum allowable imbalance of opposing loads50 grams

Maximum rotor capacity 3 liters

Approximate acceleration time 80 seconds

Approximate deceleration time 81 seconds

Weight of fully loaded rotor (buckets with covers) 15.4 kg (33.9 lb)

Rotor yoke material stainless steel

Bucket and carrier material anodized aluminum

- The critical speed range is the range of speeds over which the rotor shifts so as to rotate about its center of mass. Passing through or running at the critical speed range is characterized by some vibration.
- Relative Centrifugal Field (RCF) is the ratio of the centrifugal acceleration at a specified radius and speed ($r\omega^2$) to the standard acceleration of gravity (g) according to the following formula: $RCF = r\omega^2/g$ —where r is the radius in millimeters, ω is the angular velocity in radians per second ($2\pi \text{ RPM}/60$), and g is the standard acceleration of gravity (9807 mm/s^2). After substitution: $RCF = 1.12r (\text{RPM}/1000)^2$
- RCF inside buckets is $5095 \times g$ (tube-and-bottle buckets— $r_{\max} 201.6$ mm) or $3919 \times g$ (multiwell plate carriers— $r_{\max} 176.7$ mm).