

SPECIFICATIONS

The VORTEX-GENIE 2 Mixer is classified as "Installation Category 2", "Overvoltage Category 2", and "Pollution Degree 2".

Environmental: 0°C - 38°C (32°F - 100°F), 95% Humidity max. Indoor use only in elevation up to 2000m of altitude.

MODE	POWER REQUIRED	HZ	AMPS
G560	120V	60	0.65
G560E	230V	50	0.5
G560-100V	100V	50	1.0



ETL Listed
Conforms to UL Std. 3101-1
Certified to CAN/CSA C22.2



Weight: 4 Kg (8.8 lb)

Base Dimensions: (DxWxH) 165x122x165mm (6.5x4.8x6.5in)

PARTS ASSEMBLY LIST

To order parts for the VORTEX-GENIE 2 Mixer:

Contact your local distributor or visit www.scientificindustries.com. Please specify Part No., quantity and electric voltage.

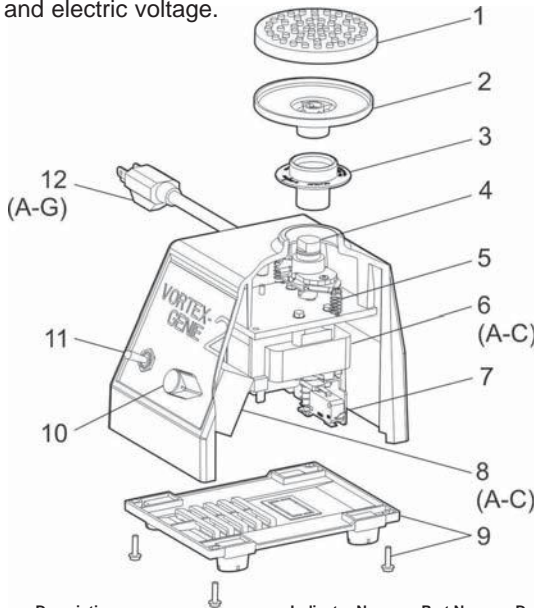

Indicator No.	Part No.	Description	Indicator No.	Part No.	Description
1	580-2013-00	Rubber Cover for 3-inch Platform	9	0K-0236-408	Bottom Closure with Feet Kit
2	0K-0500-901	3-inch Platform	10	0M-0236-209	Knob, Push-on
3	146-3011-00	Pop-off Cup	11	ESP0004	Switch, On/Off/On
4	0K-0236-902	Bearing Retainer Kit	12A	318-0510-02	120V Line Cord
5	566-0028-00	Spring, Extension, Eccentric	12B	0K-0246-901	230V Line Cord, No Plug
6A	0K-0236-905	Motor 120V Assembly	12C	0K-0256-901	230V Line Cord, Euro Plug
6B	0K-0246-915	Motor 230V Assembly	12D	0K-0266-901	230V Line Cord, British Plug
6C	0K-0286-915	Motor 100V Assembly	12E	0K-0276-901	230V Line Cord, Swiss Plug
7	ESP0005	Micro Switch	12F	0K-0286-901	100V Line Cord
8A	EPP0005	Speed Control 120V	12G	ECP0021	Australian Plug (only)
8B	EB-0246-500	Speed Control 240V			
8C	EB-0286-500	Speed Control 100V			