

Installation and Operation Manual

Thermo Scientific Revco® Laboratory Refrigerators



© 2010 Thermo Fisher Scientific. All rights reserved.

Table of Contents

1	Introduction	1
2	Safety Precautions	1
3	Pre-Installation	1
	3.1 Unpacking	1
4	Installation	2
	4.1 Location	2
	4.2 Anti-Tip Brackets	2
	4.3 Wiring	2
	4.4 Leveling	2
	4.5 Door Seal	2
	4.6 Door Operation	2
	4.6.1 Adjustable Hinged Glass Doors (Undercounter Models Only)	2
	4.6.2 Sliding Glass Doors	3
	4.7 Final Checks	3
5	Shelves and Drawer Slides	3
6	Control Panel	4
	6.1 Control Panel Features	4
	6.2 Display Functions	5
	6.3 Alarm Setpoints	5
	6.4 Service Mode Parameters	5
7	Operation	6
	7.1 Start Up	6
	7.2 Product Loading Guidelines	6
	7.3 Automatic Defrost	6
	7.4 Temperature Setpoint Control	6
	7.5 Interior Light Switch (Glass Door Units Only)	6
8	Alarm Systems	7
	8.1 Operating the Alarm	7
	8.2 Local and Remote Alarms	7
	8.3 Installing a Remote Alarm (Optional)	7
	8.4 Alarm Test	7
	8.4.1 Theory of Operation	7
	8.4.2 Alarm Test Procedure	7

9	Chart Recorders	8
9.1	Set Up and Operation.....	8
9.2	Power Supply	8
9.3	Changing Chart Paper	8
9.4	Calibration Adjustment	8
10	Maintenance	9
10.1	Cleaning the Drawers and Cabinet Interior.....	9
10.2	Removing the Drawers	9
10.3	Reinstalling the Drawers.....	9
10.4	Cleaning the Condenser.....	9
11	Troubleshooting	10
12	Accessories	11

1 Introduction

This manual provides installation and operation instructions for laboratory refrigerators, including general purpose, pharmacy, and chromatography models.

The control system, standard on all models, includes:

- Key-operated power and alarm switch
- Preset temperature setpoint (+4°C)
- Digital temperature display with 0.1°C resolution
- Graphic temperature display
- Audible and visual power failure indicators
- Alarm silence, ringback, and automatic reset functions
- Pushbutton alarm test

Other standard features include:

- Keyed door locks
- Remote alarm contacts
- CFC-free refrigerant
- CFC-free foamed in-place urethane insulation
- Quiet, hermetically sealed refrigeration compressors

Seven day chart recorders are available as optional accessories on all models. For descriptions of other options and accessories, refer to Section 12.

2 Safety Precautions

In this manual and on labels attached to this product, the words WARNING and CAUTION mean the following:

- **WARNING:** a potentially hazardous situation which, if not avoided, could result in serious injury or death.
- **CAUTION:** a potentially hazardous situation which, if not avoided, may result in minor or moderate injury or damage to the equipment.

Before installing, using or maintaining this product, please be sure to read this manual and product warning labels carefully. Failure to follow these instructions may cause this product to malfunction, which could result in injury or damage.

The following important safety precautions apply to this product:

- Use this product only in the way described in the product literature and in this manual. Before using it, verify that this product is suitable for its intended use.
- Do not modify system components, especially the controller. Use OEM exact replacement equipment or parts. Before use, confirm that the product has not been altered in any way.
- Your unit must be properly grounded in conformity with national and local electrical codes. Never connect the unit to overloaded power sources.
- Disconnect the unit from all power sources before cleaning, troubleshooting, or performing other maintenance on the product or its controls.

3 Pre-Installation

3.1 Unpacking

At delivery, examine the exterior for physical damage while the carrier's representative is present. If exterior damage is present, carefully unpack and inspect the unit and all accessories for damage.

If there is no exterior damage, unpack and inspect the equipment within five days of delivery. If you find any damage, keep the packing materials and immediately report the damage to the carrier. Do not return goods without written authorization. When submitting a claim for shipping damage, request that the carrier inspect the shipping container and equipment.

4 Installation

Do not exceed the electrical and temperature ratings.



CAUTION! Improper operation of the equipment could result in dangerous conditions. To preclude hazard and minimize risk, follow all instructions and operate within design limits noted on the dataplate.

4.1 Location

Install the unit in a level area free from vibration with a minimum of 6 inches of space on the sides and rear and 12 inches at the top.

Do not position the equipment in direct sunlight or near heating diffusers, radiators, or other sources of heat. The ambient temperature range at the location must be 59 to 90°F (15 to 32°C).

4.2 Anti-Tip Brackets

To prevent tipping, be sure to install the provided brackets, following the instructions on the next page.

4.3 Wiring



CAUTION! Connect the equipment to the correct power source. Incorrect voltage can result in severe damage to the equipment.



DANGER! For personal safety and trouble-free operation, this unit must be properly grounded before it is used. Failure to ground the equipment may cause personal injury or damage to the equipment. Always conform to the National Electrical Code and local codes. Do not connect unit to already overloaded power lines.

Always connect the equipment to a dedicated (separate) circuit. Electrical codes require fuse or circuit breaker protection for branch circuit conductors. Use time delay fuses for #12 AWG circuits.

Chromatography refrigerators are equipped with a duplex vapor-proof interior outlet with a maximum of 4 amps per receptacle.

The wiring schematic is attached to the back of the cabinet.

4.4 Leveling

It is important to make sure the unit is level. Use thin sheets of metal to level units equipped with casters.

Undercounter models come with leveling feet installed, with casters provided in a bag inside the cabinet. The unit must be level. To level undercounter units, rotate the leveling screws, located under the front corners of the unit, until the unit is level. If the floor is seriously out of level, you may need to shim the corners with thin sheets of metal.

4.5 Door Seal

To check the door seal, complete the following steps:

1. Open the door.
2. Insert a strip of paper (a couple of inches wide) between the door gasket and the cabinet flange and close the door.
3. Slowly pull the paper strip from the outside. You should feel some resistance.
4. Repeat this test at 4-inch intervals around the door. If the door does not seal properly, replace the gasket.



CAUTION! Door seal integrity is critical for refrigerators and freezers. A loose fitting gasket allows moist air to be drawn into the cabinet, resulting in quicker frost buildup on the evaporator coil, longer running time, poor temperature maintenance, and increased operation cost.

4.6 Door Operation

Solid doors and standard glass doors for models larger than the undercounter model stay open if opened 90 degrees. Door spring tension cannot be adjusted.

If the self-closing doors do not work properly, make sure the unit is level.

4.6.1 Adjustable Hinged Glass Doors (Undercounter Models Only)

On undercounter models with hinged glass doors, you can use a regular screwdriver to adjust spring tension and center each door on its frame. The adjustment screws (“torque” for tension and “sag” for door placement) are located on the bottom hinge bracket (shown below in Figure 1).

Hinged glass doors can be propped open with metal braces at the bottom hinges. Open the door 90 degrees or until you feel some resistance. Push the door open past the resistance and the metal braces engage. To close the door, push it toward the unit (past the resistance).

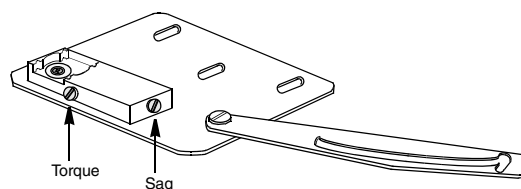

Figure 1. Undercounter Hinge Bracket for Glass Door Adjustments



CAUTION! Do not overtighten the tension as damage to the equipment can result.



WARNING! Disconnect equipment from main power before attempting any maintenance to equipment or its controls.



WARNING: SAFETY INSTRUCTIONS

- REFRIGERATOR/FREEZER MUST BE SECURED BY THE ANTI-TIP BRACKET SUPPLIED
- UNLESS PROPERLY INSTALLED, REFRIGERATOR/FREEZER COULD TIP WHEN SHELVES/ DRAWERS ARE LOADED. INJURY AND DAMAGE TO EQUIPMENT AND CONTENTS MAY RESULT FROM REFRIGERATOR/ FREEZER TIPPING
- THIS REFRIGERATOR/FREEZER HAS BEEN DESIGNED TO MEET ALL RECOGNIZED INDUSTRY TIP STANDARDS FOR ALL NORMAL CONDITIONS.

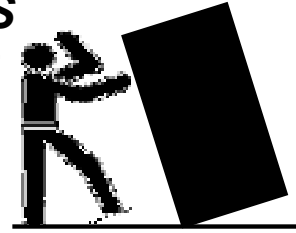

INSTALLATION INSTRUCTIONS:

Installation instructions are provided for wood and concrete floors. Any other type of construction may require special installation techniques as deemed necessary to provide adequate fastening of the Anti-Tip bracket to the floor. [For installation on floors other than wood or concrete, please contact technical support.](#)

The use of this bracket does not prevent the tipping of the Refrigerator/Freezer when not properly installed.

Materials Supplied

1. Anti-Tip Bracket (1)
2. 5/16" Lag Bolt (2)
3. Lag Screw Anchor (2), for concrete installation only
4. Bracket location template

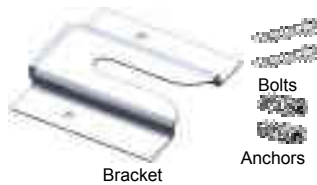

Tools Required

Wood Floor

- Flashlight
- Tape Measure
- Drill
- 15/64" (6mm) Drill Bit
- 1/2" (13mm) Wrench
- 3/4" (19mm) Wrench

Concrete Floor

- Flashlight
- Tape Measure
- Hammer Drill
- 1/2" (13mm) Masonry Bit
- 1/2" (13mm) Wrench
- 3/4" (19mm) Wrench

Step 1

Locating the Bracket

- Determine where you want the centerline of the refrigerator/freezer to be
- Place the included template on the floor lined up with the centerline of the refrigerator/freezer and keep 6"-12" between the wall and the back of the unit
- On the floor, mark the location of Hole #1 & Hole #2 (also Hole #3 & Hole #4 for 50ft³ & 75ft³ models).

Step 2

Anti-Tip Bracket Installation

Wood Construction

- Drill 15/64" (6mm) pilot holes in locations marked in step 1
- Place bracket on floor aligned with holes
- Use supplied lag bolts to attach bracket to floor

Concrete Construction

- Drill 1/2" (13mm) holes in locations marked in step 1 with masonry bit
- Slide Lag Screw Anchors into holes to be flush with floor surface
- Place bracket on floor aligned with holes
- Use supplied lag bolts to attach bracket to floor

Step 3

Adjusting Bolt in Refrigerator/Freezer

- Locate 1/2" bolt attached to bottom of cabinet
- Unscrew 1/2" bolt until there is the required clearance between floor and head of bolt as shown in Figure 1
- Tighten lock nut against bottom of unit

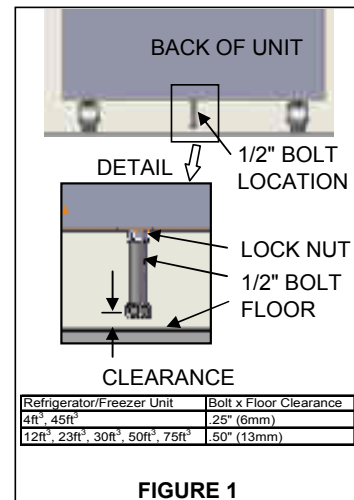

FIGURE 1

Step 4

Refrigerator/Freezer Positioning

- Line up 1/2" bolt installed in Step 3 with anti-tip bracket
- Roll or slide Refrigerator/Freezer into position until bolt stops against bracket
- Lock the casters

Step 5

Checking the Installation

- Complete the installation of the Refrigerator/Freezer per the installation instructions provided with the product.
- Check to see if the Anti-Tip bracket is installed properly by shining light under cabinet and confirming bolt in cabinet is secured by bracket on floor

4.6.2 Sliding Glass Doors

45 ft³ models have self-closing sliding glass doors.

If the self-closing mechanism is not working properly, check to make sure that the unit is level.

The sliding glass doors can be locked in the closed position, using the tubular key provided. To lock these doors:

1. Locate the spring-loaded lock bolt at the bottom left of the right-hand door frame.
2. The lock bolt has a small red dot. Insert the key over the bolt, lining up the dot with the ridge on the key.
3. Rotate the lock bolt one half turn so that the dot is at the bottom of the bolt.
4. Remove the key and push in the bolt to lock the door. The door can be locked only when the dot is in the bottom position.

To unlock the doors:

1. Insert the key over the bolt, lining up the dot with the ridge on the key.
2. Rotate the lock bolt one half turn so that the dot moves back to the top of the bolt. The bolt will then spring back to the unlocked position.

To hold the right-hand door open, slide the door to the left and use the hook located in the side of the left-hand door.

4.7 Final Checks

Before startup, complete the following steps:

1. Make sure that the unit is free of all wood or cardboard shipping materials, both inside and outside.
2. Verify that the unit is connected to a dedicated circuit.



CAUTION! Connect the equipment to a separate, dedicated, power source. Power fluctuations can result in severe damage to the equipment.

5 Shelves and Drawer Slides

For safety in shipping, the shelves are packaged and secured inside the cabinet. Insert the shelf support hangers (included with the shelves) into the built-in pilasters (located on the inside walls of the cabinet interior) at the desired locations. Position the shelves on the flat supports (refer to Figure 2).

Note: *The number of shelves supplied per cabinet varies according to type of unit and size of cabinet.*

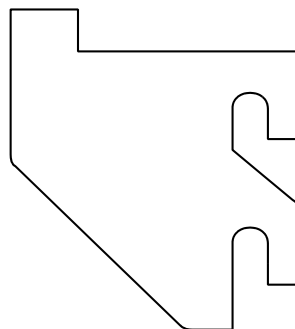

Figure 2. Shelf Support Hanger

Drawer slides (standard for pharmacy refrigerators) are similar but have a small wire safety clip at the front pilaster which prevents the slides from falling when the drawers are removed. To change the position of the drawer slides, complete the following steps:

1. Locate the safety clip.
2. Slip your fingernail or a small screwdriver under the bottom of the wire clip and pry it out toward the inside of the refrigerator.
3. Lift up the slide at front. The slide is free to move from the front pilaster.
4. The drawer slide must be removed from the rear pilaster at approximately a 45 degree angle toward the center of the cabinet.
5. Pull the slide toward the front of the cabinet.

For more information on removing and reinstalling the drawers, refer to Section 10 on page 9.

6 Control Panel

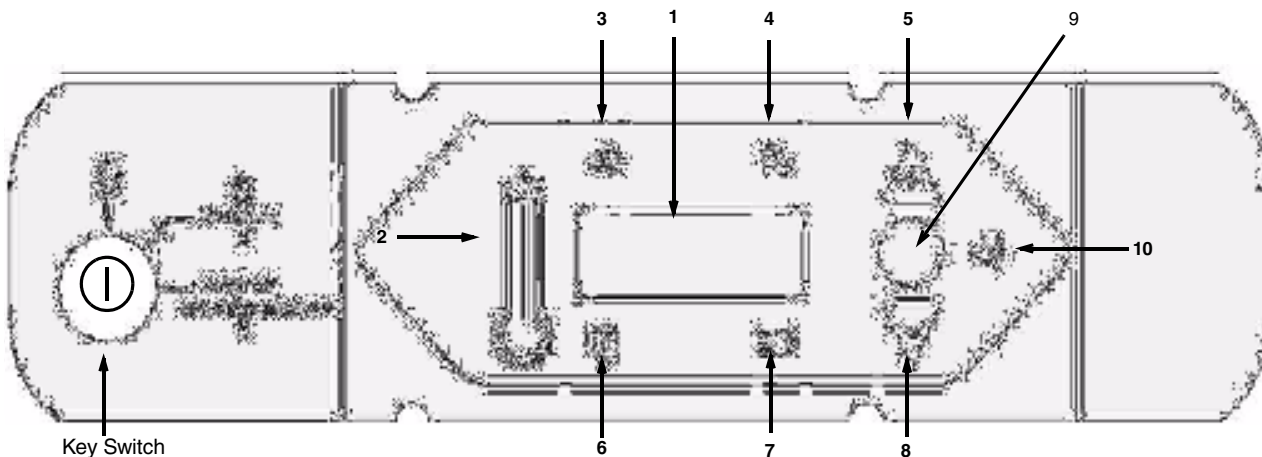

Figure 3. Refrigerator Control Panel

6.1 Control Panel Features

The control panel is located on the top right side of your refrigerator. You can use the three pushbuttons (#5, #8, and #9 in Figure 3) to change the temperature display (#1) or to adjust temperature and alarm setpoints. The thermometer display (#2) provides a quick visual indicator of current cabinet temperature and alarm conditions.

Before starting up your refrigerator, take some time to review the control panel functions:

1. Main temperature display — during normal operation, shows cabinet temperature in degrees Celsius, as measured by the sensor inside the cabinet. You can use the buttons to display other values such as setpoints and extreme values. The number in the main display flashes when you are changing a value.
2. Thermometer — shows cabinet temperature and alarm conditions. There are 10 horizontal bars: 9 are displayed during normal operation, the tenth (top) bar indicates a warm alarm condition. The number of bars illuminated indicates approximate cabinet temperature. Depending on alarm settings, 4 or 5 bars illuminated indicate that the cabinet is at setpoint.

For example, suppose that the cabinet temperature setpoint is +4°C and that the warm and cold alarm setpoints are 8°C and 0°C. Then the number of bars illuminated indicates cabinet temperature as follows:

bulb only	0°C (cold alarm)	6 bars	4.8
1 bar	0.8	7 bars	5.6
2 bars	1.6	8 bars	6.4
3 bars	2.4	9 bars	7.2
4 bars	3.2	10 bars	8 (warm alarm)
5 bars	4 (setpoint)		

When cabinet temperature exceeds the warm alarm setpoint, the top bar of the thermometer flashes. When temperature is lower than the cold alarm setpoint, the bulb flashes.

When you are in programming mode (described in Table 2) the thermometer shows the setpoint value you are changing.

3. Power failure — illuminated when the main power supply is interrupted. In this case the audible alarm also sounds.
4. Service required — illuminated when the controller is in service programming mode or when simulated warm or cold alarm conditions are failing to occur during an alarm test.
5. Increase — pushbutton used to increase setpoint values in programming mode and for various display functions.
6. Door ajar — illuminated when the refrigerator door is open and the alarm is activated (key switch turned to the alarm position). (This feature is not available for 45 ft³ sliding glass door models.)
7. Battery low — illuminated when the backup battery is low.
8. Decrease — pushbutton used to decrease setpoint values in programming mode and for various display functions.
9. Scan — pushbutton used to change the main display and for various other functions.
10. Audible alarm — illuminates during warm and cold alarm conditions.

For full descriptions of display, programming, and service functions, refer to Tables 2, 3, and 4 on page 5.

6.2 Display Functions

Table 2. Control Panel Display Functions (including optional alarm functions)

Function	Meaning	Sequence	Display
Normal operation	Default display while refrigerator is running	—	Temperature display, thermometer show cabinet temperature.
Cold excursion	Show coldest cabinet temperature since last startup or reset	Press ▾	Thermometer, display show cold excursion while button is pressed.
Warm excursion	Show warmest cabinet temperature since last startup or reset	Press ▲	Thermometer, display show warm excursion while button is pressed.
Mute	Silence audible alarm	Press Scan	Thermometer, display show cabinet temperature, alarm icon continues to flash.
Reset	Return to default display after excursion or alarm condition	Press ▲ and ▾ simultaneously, hold for five seconds	Excursion values are reset; thermometer, display show cabinet temperature. Display blinks to confirm reset.
Alarm test	Test by simulating warm and cold alarm conditions; key switch must be in alarm mode	Press ▲ and Scan simultaneously, hold for five seconds	Display and thermometer show simulated cabinet temperature, alarms flash and sound as appropriate. Alarms clear when test is completed.

6.3 Alarm Setpoints

To enter programming mode, press Scan, hold for 5 seconds, and release. The first two values displayed are the warm and cold alarm setpoints. Note that the alarm setpoints cannot be adjusted when the key switch is in the alarm position.

Table 3. Alarm Setpoint Programming Functions (with Alarm Option Only)

Function	Programming Sequence
Adjust cold alarm setpoint	Enter programming mode by pressing Scan and holding for 5 seconds. On release, the current cold alarm setpoint value flashes in the temperature display; use ▾ and ▲ to adjust it. The display automatically returns to normal operating mode 30 seconds after the last key entry or after scrolling through all available functions and parameters.
Adjust warm alarm setpoint	Enter programming mode and press Scan repeatedly. The current warm alarm setpoint value then flashes in the temperature display; use ▾ and ▲ to adjust it. The display automatically returns to normal operating mode 30 seconds after the last key entry or after scrolling through all available functions and parameters.

6.4 Service Mode Parameters

When the key switch is *not* turned to third (alarm) position, you can access service parameters by entering programming mode and pressing Scan for an additional 5 seconds. On release of the button, the display will go blank, then display “SER” with the service wrench icon illuminated. Then the *firmware checksum* (read-only) will be displayed for about 4 seconds. Pressing Scan repeatedly scrolls through the available service functions. While you are in service mode, the wrench icon is illuminated. For any flashing parameter you can use ▾ and ▲ to adjust the value.



CAUTION! Resetting any of the following parameter values could adversely affect the performance of your refrigerator. These settings very rarely need to be changed for normal +4°C operation. Be sure to call Service before making any adjustments to parameter values.

Table 4. Programming Parameters

Parameter	Display	Notes
1. Offset	Value	Center air temperature calibration. Default value is 0 (maximum + or - 2.9).
2. Cut On	Cut (2 sec.); On (2 sec.); then value	Cabinet temperature at which compressor starts to cool down to setpoint. Default value is 6°C.
3. Differential	dIF (2 sec.); then value	Cut on – differential = temperature at which compressor stops after achieving cabinet temperature setpoint. Default value is 3.
4. Defrost Interval	dEF (2 sec.); Int (2 sec.); then value	Range 1 to 12 hours; default value is 01.
5. Defrost Duration	dEF (2 sec.); dur (2 sec.); then value	Range 5 to 30 minutes; default value is 15.
6. Defrost High-temp Termination	dEF (2 sec.); HI (2 sec.); then value	Temperature at evaporator at which defrost cycle terminates; default value is 4°C.
7. Short Cycle Delay	SHO (2 sec.); Cyc (2 sec.); then value	Range 0 to 15 minutes; default value is 0.
8. Control Probe Temperature	Cnt (2 sec.); Prb (2 sec.); then value	Display only.
9. Network address	nEt (2 sec.); Adrt (2 sec.); then value	Can only be modified by RS-485 communications software.
10. Defrost Probe Temperature	dEF (2 sec.); Prb (2 sec.); then value	Display only.

7 Operation

7.1 Start Up

To start up the refrigerator, complete the following steps:

1. Plug in the power cord.
2. Insert the key in the switch and turn the power on.
3. Rotate the power switch to the ALARM ON position when the temperature drops below the warm alarm setpoint.
4. Allow the unit to reach operating temperature before loading it with any product. To stabilize the temperature profile, a 24-hour waiting period is recommended.
5. After the unit has pulled down to the desired operating temperature, turn the three position key switch one turn further clockwise to the Alarm On position. (Space Saver units have a separate alarm key switch.)
6. If you have a remote alarm, hook it up at this point (refer to Section 8.3 on page 7).
7. Whether you have a built-in alarm or a customer-installed remote alarm, you should test it following the instructions in Section 8.4 on page 7. Alarm setpoints are factory pre-set for 5.5 (warm) and 1.5°C (cold).

7.2 Product Loading Guidelines

When loading your refrigerator, take care to observe the following guidelines:

- Never load the refrigerator beyond capacity.
- Distribute the load as evenly as possible. Temperature uniformity depends on air circulation, which could be impeded if drawers are overfilled, particularly at the top of the cabinet.
- For critical applications, be sure that the alarm systems are working and active before you load any product.

7.3 Automatic Defrost

The defrosting process on all models is primarily accomplished by air circulated during off-cycle periods.

Under normal conditions, the temperature warm-up during defrost is virtually unnoticeable. However, an occasional 2°C warm-up is possible if usage is heavy and ambient conditions are extreme.

7.4 Temperature Setpoint Control

Your individual unit has been adjusted and factory tested to maintain a +4°C cabinet temperature. For laboratory refrigerators, cabinet temperature setpoint is a computed value based on the service parameters Cut On and Differential (see Table 4 on page 5).

For most applications, however, you will not need to change the temperature setpoint.

7.5 Interior Light Switch (Glass Door Units Only)

To the right of the control panel is a light switch which operates independently of the door switch.

If you leave the panel switch in the OFF position, the door switch will automatically turn on the lights when the door is opened and turn them off when the door is closed.

If you leave the panel switch in the ON position, the lights will remain on even when the door is closed.



WARNING! If you are loading your refrigerator with light-sensitive product, be sure to leave the light switch on the control panel in the OFF position.

8 Alarm Systems

8.1 Operating the Alarm

The alarm system is designed to provide visual and audible warning signals for both power failure and rise in temperature. The alarm is equipped with a battery backup.

The factory default warm alarm setpoint is 5.5°C; the default cold alarm setpoint is 1.5°C.

The alarm system is activated only when the key switch is turned to the Alarm On position. The audible warning signal sounds when there is a power failure or temperature alarm condition, or when the door is ajar for more than 2 minutes.

The Mute function (pressing the Scan button) allows you to turn off the audio warning without turning off the visual indicators.

To turn off and reset flashing visual alarms, press Δ and ∇ simultaneously.

There is also a ringback function after approximately 6 minutes if any alarm condition remains active.

8.2 Local and Remote Alarms

Refrigerators can have either a factory-installed local alarm or an optional user-installed remote alarm. Operating and testing procedures are the same for both types of alarm.

The maximum distance between a refrigerator and a remote alarm depends on the wire gauge used. Refer to Table 5 below.

Table 5. Wire Gauges and Distance to Remote Alarm

Wire Gauge	Total Wire Length (feet)	Distance to Alarm 1/2 Wire Length (feet)
20	530	265
18	840	420
16	1,330	665
14	2,120	1,060
12	3,370	1,685

8.3 Installing a Remote Alarm (Optional)

Remote alarm terminals are located at the rear of the machine compartment. The terminals are: Common, Open on Fail (Normally Closed), and Close on Fail (Normally Open).

- The remote alarm system has two keyhole slots on the back to hang the alarm system on the wall. Insert two screws, no longer than a #12 truss-head type and spaced two inches apart, into a wall and mount the alarm.
- Make the following connections:
 - Connect the common terminal on the cabinet switch to the purple wire on the alarm.
 - Connect the normally closed terminal on the cabinet to the black (“open on fail”) wire on the alarm. This connection gives an alarm when the switch contacts open.
- Plug the alarm system service cord into an electrical outlet. This alarm is designed for 115V/60 Hz, 115V/50 Hz, or 100V/50 Hz operation.

Note: *If you want the alarm signal to sound when the switch contacts **close**, connect the normally open terminal on the cabinet to the red/white (“close on fail”) wire on the alarm. The purple and red/white wires must be tied together in this application.*

The wiring diagram is attached to the inside of the alarm back cover.

8.4 Alarm Test

Note: *It is important to test your alarm system after any maintenance operation or temperature control adjustment.*

8.4.1 Theory of Operation

This test procedure applies to both factory-installed built-in alarms and optional field-installed remote alarms.

During the alarm test, the temperature sensor is artificially heated and cooled by a tiny, built-in thermoelectric heating and cooling unit which simulates both warm and cold conditions. The electronic control module notes the sensor temperature changes and the control panel displays these changes.

While this alarm testing procedure is very accurate and reliable, the temperature of the refrigerated space does not change during the alarm test.

8.4.2 Alarm Test Procedure

Note: *This test automatically advances through all steps and stops.*

- Verify that the current warm and cold alarm setpoints are within normal ranges (the warm and cold simulations may not work if the setpoints are set to extreme values).
- To start the alarm test, press Δ and Scan simultaneously and hold for five seconds. During the test the main display and thermometer bulb will indicate simulated (not actual) cabinet temperature.
- When simulated temperature exceeds the warm alarm setpoint, the alarm sounds and the alarm icon on the control panel illuminates (#10 in Figure 3 on page 4).
- The temperature display begins to drop. After a few seconds, the temperature in the display is back in the operating range.
- The alarm stops. The temperature on the display drops until the cold alarm sounds.
- The test is now complete but the alarm continues to sound until the temperature on the display is back in the operating range.

If the simulated alarm conditions do not occur during the first 5 minutes of the alarm test, the service (wrench) icon illuminates and the test is terminated. You can also terminate the test immediately by turning the key switch to the second (non-alarm) position. When during the alarm test, the temperature display does not change or the service icon illuminates, check the sensor connections.

After an alarm test has terminated, there is a 10-minute delay before the test can be run again.

9 Chart Recorders

Panel-mounted six inch recorders are available as options on all models. Recorder operation begins when the system is powered on.

9.1 Set Up and Operation

To prepare the recorder to function properly, complete the following steps:

1. Open the recorder door to access the recorder.
2. Connect the nine volt DC battery located at the recorder's upper right corner. This battery provides back-up power.
3. Install clean chart paper (refer to Section 9.3 below).
4. Remove the plastic cap from the pen stylus and close the recorder door.

Note: *The recorder may not respond until the system reaches temperatures within the recorder's range.*

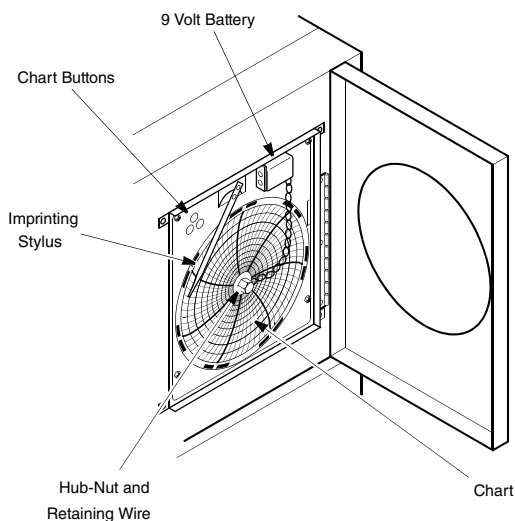

Figure 4. Six Inch Chart Recorder

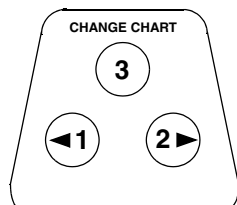

Figure 5. Chart Buttons

9.2 Power Supply

The recorder normally uses AC power when the system is operating. If AC power fails, the LED indicator flashes to alert you to a power failure. The recorder continues sensing cabinet temperature and the chart continues turning for approximately 24 hours with back-up power provided by the nine-volt battery.

The LED indicator glows continuously when main power is functioning and the battery is charged.

When the battery is low, the LED flashes to indicate that the battery needs to be changed.

9.3 Changing Chart Paper

To change the chart paper, complete the following steps:

1. Locate the pressure sensitive buttons at the front, upper left of the recorder panel.
2. Press and hold the change chart button for one second. The pen will move off the scale.
3. Unscrew the center nut, remove the old chart paper, and install new chart paper. Carefully align the day and time with the reference mark on the recorder panel (a small groove on the left side of the panel, shown in Figure 4).
4. Replace the center nut and hand tighten. Press the change chart button again to resume temperature recording.

9.4 Calibration Adjustment

This recorder has been accurately calibrated at the factory and retains calibration even during power interruptions. If required, however, adjustments can be made as follows:

1. Run the unit continuously at the control setpoint temperature. Continue steady operation for at least two hours to provide adequate time for recorder response.
2. Measure cabinet center solution temperature with a calibrated temperature monitor. (Solution temperature is measured inside the sensor bottle.)
3. Compare the recorder temperature to the solution temperature. If necessary, adjust recorder by pressing the left (#1) and right (#2) chart buttons.

Note: *The stylus does not begin to move until the button is held for five seconds.*

10 Maintenance

10.1 Cleaning the Drawers and Cabinet Interior

Pharmacy refrigerators come standard with drawers. All other refrigerators come standard with wire shelves. Additional drawers and/or shelves are offered as available options.

To clean the drawers and cabinet interior, remove the drawers following the instructions below. Use a solution of water and a mild detergent. Rinse the drawers and wipe them dry with a soft cloth.

10.2 Removing the Drawers

The drawers in all models can be removed for cleaning.

To remove the drawers, complete the following steps (refer to Figure 6):

1. Pull the drawer toward you until the slide is fully extended.
2. Lift the back of the drawer to disengage the mounting tab from the slot on the slide.
3. Raise the back of the drawer almost to a vertical position and disengage the front mounting clips from the slide.

The drawer slides are adjustable. You can position these slides in the vertical slots which are spaced at one-inch intervals.

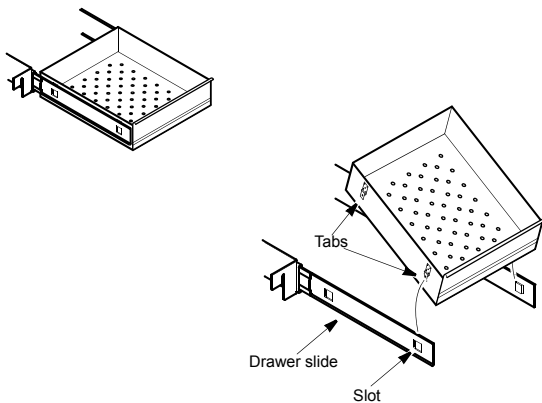

Figure 6. Drawer Removal

10.3 Reinstalling the Drawers

To reinstall the drawers, complete the following steps:

1. Pull both drawer slides toward you until the slides are fully extended.
2. Position the drawer between the slides and insert the front mounting clips into the slots on front of the slides.
3. Push the back of the drawer down between the slides and insert the drawer tabs into the back slots.

Note: *The drawers fit snugly between the slides. Push on the back of the drawer from the inside to insert the drawer tabs completely into the slots. Make sure both drawer tabs are aligned with the slots on the slides before pushing the drawer down between the slides.*

10.4 Cleaning the Condenser



WARNING! Disconnect equipment from main power before attempting any maintenance to equipment or its controls.



CAUTION! Condensers should be cleaned at least every six months. In heavy traffic areas, condensers load with dirt more quickly. Failure to keep the condenser clean can result in equipment warm-up or erratic temperatures.

Periodically check the condenser to make sure that it is clean.

In all models except for the 45 ft³ sliding glass door model, the condenser is located in the top machine compartment.

To clean the condenser:

1. Disconnect the power.
2. Remove the top grill (bottom front grill if you have a sliding glass door model).
3. Use a vacuum cleaner with hose and brush attachments to clean the front face of the finned surface.
4. Clean up any loose dust and replace the grill.
5. Reconnect the power.

11 Troubleshooting



WARNING! Troubleshooting procedures involve working with high voltages which can cause injury or death. Troubleshooting should only be performed by trained personnel.

This section is a guide to troubleshooting equipment problems.

Table 6. Troubleshooting Procedures

Problem	Cause	Solution
Unit does not operate or Power Failure Indicator is on.	Power supply	<ol style="list-style-type: none"> 1. Check that the cord is securely plugged-in. 2. Plug another appliance into the outlet to see if it is live. 3. If the outlet is dead, check the circuit breaker or fuses.
Temperature fluctuates.	Cold control	Make sure that the cold control is set correctly. Refer to Section 7.1 on page 6.
	Condenser	Make sure the condenser is clean. Refer to Section 10.4 on page 9.
	High pressure	Check the system high-pressure cut-out button. This is an encapsulated control with a rubber boot over the reset button. To reset the control, push it down; use a blunt instrument to avoid tearing the boot.
Unit warms up.	Door is open.	Make sure the door is completely closed.
	Warm product recently loaded in unit.	Allow ample time to recover from loading warm product.
	Power supply	Check for proper voltage to the unit. If there is no voltage to the unit, call an electrician.
	Compressor	<ol style="list-style-type: none"> 1. If the compressor is not running, check if the unit has a power failure alarm. If the power failure alarm light is on, have an electrician check for proper voltage to the unit. 2. If the compressor is running, open the door and look through the slotted air intake in the bottom of the evaporator cover to see if icing is present on the evaporator. If icing is present and there is no air flow behind evaporator, call technical service for assistance. The evaporator fans may be inoperative. 3. If the compressor is running and there is airflow behind the evaporator, contact an authorized service provider or call the technical support hot line for assistance.

12 Accessories

Alarm Systems

Description	Catalog No.
Standard Remote Alarm. Provides audible and visual signal in the event of temperature rise or power failure. Adaptable to telephone switchboard. Can be located up to 1/3 mile (1760 ft/536 m) from cabinet. Must be used with electronic alarm system and connected to normally-open or normally-closed remote alarm contacts. Wire not included. Specify voltage when ordering.	5612
Deluxe Electronic Remote Alarm System. User programmable to sound alarm in the event of temperature rise or power failure. Can dial up to four telephone numbers to advise of alarm condition across any telephone system which accepts pulse dialing. One System can monitor up to four individual cabinets. In addition, the System can monitor up to three groups of cabinets. Contact Customer Sales for detailed specifications. Customer installed.	6224

Special Voltages

Standard voltages are listed under *Voltage* in Specification Charts associated with each product category. Standard voltages are available at no charge; alternative voltages may be available at an extra charge. All voltages must be specified when ordering. Contact Customer Sales for more information.

Low Voltage Protection

Description	Catalog No.
Voltage Safeguard. Free-standing. Helps protect electrical equipment from damage by boosting low voltage automatically. Provided with terminal board for direct wiring. Field installed. Specify voltage when ordering.	5575

Temperature Recorders

All six inch recorders utilize pressure-sensitive chart paper (1 box @ 50 charts included); no inking is required..

Description	Catalog No.
Temperature recorder, 6 in. circular chart, seven-day drive, panel mounted. Factory installed. Specify when ordering.	6183-7
Temperature recorder, 6 in. circular chart, seven-day drive, free-standing, for all refrigerator models. Customer installed. Specify voltage when ordering.	6383-7

Chart Paper

Description	Catalog No.
Chart paper, package of 50, for six inch, seven-day recorder, -40°C to +25°C.	6184

Casters

Description	Catalog No.
Dual-Wheel Casters. Set of four, two locking, two non-locking, 3 in. diameter, for 11.5, 23.3, 29.2, 51.1, and 78.8 cu.ft models only.	6041-1

Extra Shelves

Description	Catalog No.
Zinc Plated. Full Size. For use with 23.3, 45.8, 51.5, and 78.8 cu.ft models only	6696
Zinc Plated. Half size. For use with 23.3, 45.8, 51.5, and 78.8 cu.ft models only.	6698
Zinc Plated. Full size. For use with 29.2 cu.ft models only.	6695
Zinc Plated. Half size. For use with 29.2 cu.ft models only.	6697
Zinc Plated. Full size. For use with 11.5 cu.ft models only.	6202
Zinc Plated. For use with 4.9 cu.ft models only.	7128

Drawers

Optional stainless steel drawers are offered as an alternative to standard shelving.

Description	Catalog No.
For 4.9 cu.ft Undercounter Models	
For REL-404, roll-out drawer assembly, two drawers.	7129
For 11.5 cu.ft Space Saver Models	
For REL-1204, roll-out drawer assembly, five drawers.	6599
For 23.3, 51.1, and 78.8 cu.ft Models	
For REL-2304, roll-out drawer assembly, six drawers, full adjustable, fully extendable.	6699
For REL-5004, roll-out drawer assembly, 12 drawers, fully adjustable, fully extendable.	6700
For REL-7504, roll-out drawer assembly, 18 drawers, fully adjustable, fully extendable.	6701
Additional stainless steel drawers, for 23.3, 51.1, and 78.8 cu.ft models.	6702
For 45.8 cu.ft Models only	
For REL-4504, roll-out drawer assembly, six additional stainless steel drawers, fully adjustable, fully extendable.	6703
For 29.2 cu.ft Models only	
For REL-3004, roll-out drawer assembly, six additional stainless steel drawers, fully adjustable, fully extendable.	6704

Extended Warranty Options

Note: In addition the standard full warranty on the complete product (USA and Canada), an additional four year protection on compressor and compressor parts can be supplied . This additional coverage must be purchased at the time of original product purchase. Under this contract, the manufacturer agrees to furnish a compressor FOB our factory to replace one which has been determined to be defective by manufacturer or a factory authorized Service Agency.

Description	Catalog No.
Extended Four-Year Compressor Parts Contract, all refrigerators.	6069
Extended 12-Month Comprehensive Coverage, for all models, provides additional 12-month warranty coverage, parts and labor. Contact Customer Sales for details.	6613

WEEE Compliance

WEEE Compliance. This product is required to comply with the European Union's Waste Electrical & Electronic Equipment (WEEE) Directive 2002/96EC. It is marked with the following symbol. Thermo Fisher Scientific has contracted with one or more recycling/disposal companies in each EU Member State, and this product should be disposed of or recycled through them. Further information on our compliance with these Directives, the recyclers in your country, and information on Thermo Scientific products which may assist the detection of substances subject to the RoHS Directive are available at www.thermo.com/

Great Britain



WEEE Konformität. Dieses Produkt muss die EU Waste Electrical & Electronic Equipment (WEEE) Richtlinie 2002/96EC erfüllen. Das Produkt ist durch folgendes Symbol gekennzeichnet. Thermo Fisher Scientific hat Vereinbarungen getroffen mit Verwertungs-/Entsorgungsanlagen in allen EU-Mitgliederstaaten und dieses Produkt muss durch diese Firmen wiederverwertet oder entsorgt werden. Mehr Informationen über die Einhaltung dieser Anweisungen durch Thermo Scientific, die Verwerter und Hinweise die Ihnen nützlich sein können, die Thermo Fisher Scientific Produkte zu identifizieren, die unter diese RoHS. Anweisung fallen, finden Sie unter www.thermo.com/

Deutschland



Conformità WEEE. Questo prodotto deve rispondere alla direttiva dell'Unione Europea 2002/96EC in merito ai Rifiuti degli Apparecchi Elettrici ed Elettronici (WEEE). È marcato col seguente simbolo. Thermo Fisher Scientific ha stipulato contratti con una o diverse società di riciclaggio/smaltimento in ognuno degli Stati Membri Europei. Questo prodotto verrà smaltito o riciclato tramite queste medesime. Ulteriori informazioni sulla conformità di Thermo Fisher Scientific con queste Direttive, l'elenco delle ditte di riciclaggio nel Vostro paese e informazioni sui prodotti Thermo Scientific che possono essere utili alla rilevazione di sostanze soggette alla Direttiva RoHS sono disponibili sul sito www.thermo.com/

Italia



Conformité WEEE. Ce produit doit être conforme à la directive euro-péenne (2002/96EC) des Déchets d'Equipements Electriques et Electroniques (DEEE). Il est marqué par le symbole suivant. Thermo Fisher Scientific s'est associé avec une ou plusieurs compagnies de recyclage dans chaque état membre de l'union européenne et ce produit devrait être collecté ou recyclé par celles-ci. Davantage d'informations sur la conformité de Thermo Fisher Scientific à ces directives, les recycleurs dans votre pays et les informations sur les produits Thermo Fisher Scientific qui peuvent aider le détection des substances sujettes à la directive RoHS sont disponibles sur www.thermo.com/

France



Important

For your future reference and when contacting the factory, please have the following information readily available:

Model Number: _____

Serial Number: _____

Date Purchased: _____

The above information can be found on the dataplate attached to the equipment. If available, please provide the date purchased, the source of purchase (manufacturer or specific agent/rep organization), and purchase order number.

IF YOU NEED ASSISTANCE:

SALES DIVISION

Phone: 1-866-984-3766 (866-9-THERMO)

LABORATORY PARTS and SERVICE

Phone: 1-800-438-4851

TECHNICAL SUPPORT

Phone: 1-800-438-4851

Thermo Fisher Scientific Inc.

275 Aiken Road
Asheville, NC 28804
United States

www.thermofisher.com

Thermo
SCIENTIFIC

34830H67