



New Brunswick™ Products

Operating Manual M1194-0051 Revision D+

The enclosed Operating Manual was originally produced by the New Brunswick Scientific Company, Inc.

About Eppendorf

Eppendorf is a biotech company which develops, produces and distributes systems for use in life-science research laboratories worldwide. After more than 60 years the vision of the company is just as valid and up-to-date as it ever was: our goal is to improve the living conditions of man. Since 1945 we have succeeded in continually producing high-quality products and technology, integrated as systems which solve problems in a holistic way. Information about Eppendorf is available online at: www.eppendorf.com

About New Brunswick Scientific

New Brunswick Scientific, purchased by Eppendorf in 2007, was founded in 1946 and is a global leader in the design and manufacturing of advanced biotechnology equipment. New Brunswick Scientific's innovative systems are used in a broad range of research and commercial applications, spanning biomedical, environmental, food and cosmetic sciences. With the world's largest selection of lab shakers and a comprehensive line of fermentors, bioreactors, CO2 incubators and freezers, New Brunswick Scientific is proud to support the groundbreaking advances of its customers worldwide. Information about New Brunswick Scientific is available online at: www.newbrunswick.eppendorf.com

For information related to warranty or service, please contact your local Eppendorf sales organization or distributor: www.eppendorf.com/worldwide

Eppendorf® and the Eppendorf logo are registered trademarks of Eppendorf AG, Germany. New Brunswick™ is a trademark of Eppendorf AG, Germany. All rights reserved, including graphics and photos. Copyright © 2013.



Guide to Operations

innova[™] **2180** Digital Platform Shaker 0.180-inch Stroke

MANUAL NO: M1194-0051
Revision D
August 20, 2002



NEW BRUNSWICK SCIENTIFIC CO., INC.

BOX 4005 • 44 TALMADGE ROAD • EDISON, NJ 08818-4005

Telephone: 1-732-287-1200 • 1-800-631-5417

Fax: 732-287-4222 • Telex: 4753012 NBSCO

Internet: <http://www.nbsc.com> • E-mail: bioinfo@nbsc.com

INTERNATIONAL OFFICES:

THE NETHERLANDS

New Brunswick Scientific BV
Kerkenbos 1101, 6546 BC Nijmegen
P.O Box 6826, 6503 GH Nijmegen
Holland
Tel: 31 (0)24 3717 600
Fax: 31 (0)24 3717 640
E-mail: sales@nbsbv.nl

FRANCE

New Brunswick Scientific SARL
3, rue des Deux-Boules
75001 Paris
France
Tel: 33 (0)1 4026 2246
Fax: 33 (0)1 4026 5423
E-mail: sales@nbssarl.fr

UNITED KINGDOM

New Brunswick Scientific (UK) Ltd.
Edison House, 163 Dixons Hill Road
North Mymms, Hatfield, Herts. AL9 7JE
United Kingdom
Tel: 44 (0)1707 275733
Fax: 44 (0)1707 267859
E-mail: bioinfo@nbsuk.co.uk

BELGIUM

New Brunswick Scientific NV/SA
't Veldeke 1
B-1970 Wezembeek-Oppem
België/Belgique
Tel: 32 (0)2 731 6787
Fax: 32 (0)2 731 8130
E-mail: sales@nbsnv-sa.be

GERMANY

New Brunswick Scientific GmbH
In Der Au 14
D-72622 Nürtingen
Deutschland
Tel: 49 (0)7022 932490
Fax: 49 (0)7022 32486
E-mail: sales@nbsgmbh.de

CHINA

New Brunswick Scientific Co., Inc.
9A. AiBang Building
585 LingLing Road
Shanghai 200030, P.R. China
Tel: 86 21 6481 2658
Fax: 86 21 6481 2665
E-mail: nbschc@online.sh.cn

THIS PAGE INTENTIONALLY BLANK

**CAUTION!**

This equipment *must* be operated as described in this manual. If operational guidelines are not followed, equipment damage and personal injury *can* occur.

Please read the entire User's Guide before attempting to use this unit.

Do not use this equipment in a hazardous atmosphere or with hazardous materials for which the equipment was not designed.

New Brunswick Scientific Co., Inc. (NBS) is not responsible for any damage to this equipment that may result from the use of an accessory not manufactured by NBS.

THIS PAGE INTENTIONALLY BLANK

Copyright Notice

New Brunswick Scientific Company, Inc.
Box 4005 44 Talmadge Road
Edison, New Jersey 08818-4005

© Copyright 2002 New Brunswick Scientific Co., Inc.

All Rights Reserved.

Reproduction, adaptation, or translation without prior written permission from New Brunswick Scientific is prohibited.

Disclaimer Notice

New Brunswick Scientific Co., Inc. reserves the right to change information in this document without notice. Updates to information in this document reflect our commitment to continuing product development and improvement.

Manual Conventions



NOTE:

Notes contain essential information that deserves special attention.



CAUTION!

Caution messages appear before procedures which, if caution is not observed, could result in damage to the equipment.



WARNING!

Warning messages alert you to specific procedures or practices which, if not followed correctly, could result in serious personal injury.

Bold

Text in bold face type emphasizes key words or phrases.

THIS PAGE INTENTIONALLY BLANK



WARRANTY

Every Instrument manufactured by the New Brunswick Scientific Co., Inc. is warranted to be free from defects in material and workmanship. This apparatus is warranted for 2 years or 10,000 hours (whichever comes later) against faulty components and assembly and our obligation under this warranty is limited to repairing or replacing the instrument or part thereof, which shall within 2 years or 10,000 hours (whichever comes later) after the date of shipment, prove to be defective after our examination. This warranty does not extend to any NBS products which have been subjected to misuse, neglect, accident or improper installation or application; nor shall it extend to products which have been repaired or altered outside the NBS factory without prior authorization from New Brunswick Scientific Co., Inc.

THIS PAGE INTENTIONALLY BLANK

TABLE OF CONTENTS

1	OVERVIEW	13
2	FEATURES.....	15
2.1	GENERAL DESCRIPTION.....	15
2.2	UNIVERSAL POWER MODULE.....	16
2.3	CONTROL PANEL	16
2.3.1	<i>LED Display</i>	17
2.3.2	<i>Keypad</i>	17
2.3.3	<i>Status Indicator Lights</i>	18
2.3.4	<i>Function Indicator Lights</i>	18
2.4	PLATFORM ASSEMBLIES.....	18
2.5	HEAVY DUTY CONSTRUCTION	19
2.5.1	<i>Bearings</i>	19
2.5.2	<i>Motor</i>	20
2.6	TEMPERATURE/MONITOR OPTION.....	20
2.7	ELECTRONIC BOARDS.....	20
3	INSTALLATION	21
3.1	UNPACKING.....	21
3.2	CHECKING VOLTAGE CONFIGURATION	21
3.3	SPACE REQUIREMENTS.....	21
3.4	ELECTRICAL CONNECTIONS	22
3.5	INSTALLING THE PLATFORM.....	23
3.6	CLAMP INSTALLATION	23
4	OPERATION.....	25
4.1	STARTING THE SHAKER	25
4.2	CONTINUOUS (UNLIMITED) RUN	25
4.3	CHECKING A SETPOINT.....	25
4.4	TIMED FUNCTIONS	26
4.4.1	<i>Setting the Timer</i>	26
4.4.2	<i>Stopping the Alarm</i>	26
4.4.3	<i>Cancelling the Timer</i>	26
4.5	ALARM FUNCTIONS.....	26
4.6	TOTAL RUNNING TIME	27
4.7	TEMPERATURE/MONITOR OPTION.....	27
4.8	RECORDER ADAPTATION.....	28
5	MAINTENANCE	29
5.1	CLEANING	29
6	SERVICE	31
6.1	REPLACING FUSES.....	31
6.2	CHANGING VOLTAGE	32

6.3	FUSING	33
6.3.1	<i>From Single to Double Fusing</i>	33
6.4	BELT REPLACEMENT	35
6.4.1	<i>Belt Adjustment</i>	38
6.5	MOTOR ASSEMBLY REPLACEMENT	39
6.6	TEMPERATURE/MONITOR OPTION	41
6.7	REPLACING ELECTRONIC BOARDS	43
6.7.1	<i>ESD Precautions</i>	43
6.8	MAINT INDICATOR	44
7	PARTS & ACCESSORIES	45
7.1	SERVICE PARTS	45
7.2	INNOVA 2180 INTERCHANGEABLE PLATFORMS	45
7.3	ACCESSORY FLASK CLAMPS	46
7.4	CLAMP MOUNTING HARDWARE KIT	46
7.4.1	<i>Hardware for 10 mL to 500 mL Clamps</i>	46
7.4.2	<i>Hardware for 1-Liter to 6-Liter Clamps</i>	47
7.5	TEMPERATURE/MONITOR OPTION	47
8	SPECIFICATIONS	49
9	DRAWINGS	51
9.1	CONTROL SCHEMATIC	51
9.2	DRAWING LIST	56
10	INDEX	57

1 OVERVIEW

The Innova 2180 Digital Platform Shaker will provide you with reliable and maintenance-free operation which is characteristic of all NBS shakers. The Innova 2180 series are among the newest generation of NBS shakers; they incorporate a variety of state-of-the-art components and features to permit the precision operation necessary for your exacting scientific experiments.

This manual is intended to provide a complete understanding of Innova 2180 Digital Platform Shaker installation, operation, basic components, and basic preventive maintenance and service issues. This manual also includes a guide to key service procedures, intended for use only by authorized service technicians.

We recommend that you completely familiarize yourself with this manual prior to operating the Innova 2180.

THIS PAGE INTENTIONALLY BLANK

2 FEATURES

2.1 General Description

The Innova 2180 is a benchtop shaker utilizing a triple eccentric counterbalanced drive to provide horizontal plane rotary motion in a 0.180-inch (4.6mm) circular orbit. A Proportional/Integral (PI) Microprocessor controller with instantaneous digital feedback controls the speed over a range of 25-800 RPM.

The shaker may be operated either continuously or in a timed mode via a programmable timer for shaking periods of 0.1 hour to 99.9 hours. A temperature/monitoring option is available for the measurement, display and documentation of sample temperature (*see Section 2.6 ,Temperature/Monitor Option*).

The Innova 2180 is equipped with audible and visible alarms which are activated when an alarm condition exists, as follows:

- The end of a timed run
- Deviations of shaking speed outside of tolerance limits

In addition to a custom-ordered or customer-provided reaction-block platform, a wide variety of platforms can be used with the Innova 2180. Dedicated platforms are available for a variety of flask sizes. Universal platforms and utility trays are also available (*see Section 7.2, Interchangeable Platforms*).

Figure 1: Front View

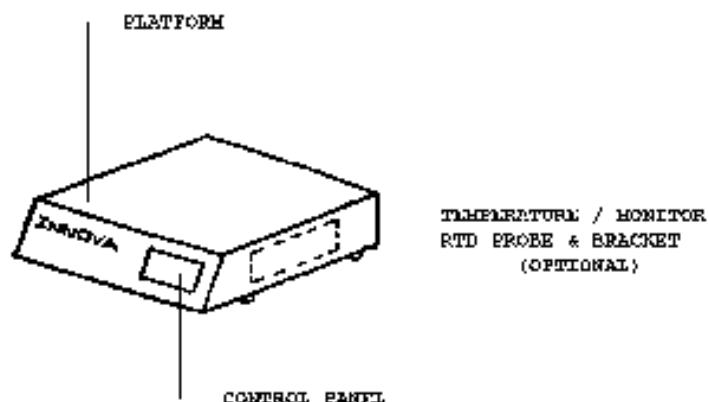
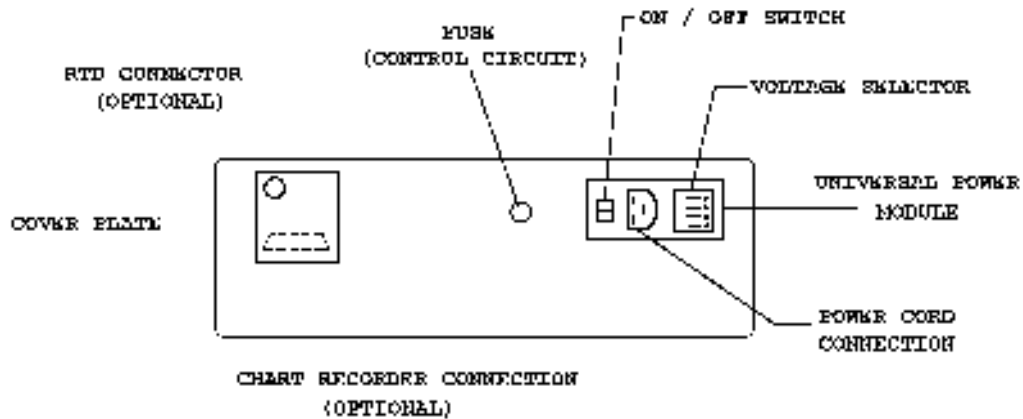

Figure 2: Rear View



2.2 Universal Power Module

The power module contains a voltage card and fuse holder which are used to select the appropriate voltage and fusing. This universal power entry system adapts to worldwide power requirements. Voltage and fusing has been set prior to shipment. Innova shakers are available in 100V, 120V, 220V and 240V configurations that accommodate both 50 and 60 Hz frequencies.



WARNING!

Before you plug the unit into a power source, it is critical to check the voltage.

On the rear panel, confirm that the voltage setting is correct by checking the voltage indicator in the universal power module (Figure 2) and the voltage listed on the Caution label that is located over the power switch and power cord connection.

2.3 Control Panel

The control panel (*see Figure 3*), located on the front of the instrument, serves as the operator interface. The keypad has four keys marked Start/Stop, σ , τ , and Select. A three-digit LED display provides numeric values as well as some letter codes. There are four **function indicator lights** and four **status indicator lights** on the control panel as well. A general description of the display, user interface keys and indicators follows. For operation of the control panel, *see Section 4*.

Figure 3: Control Panel

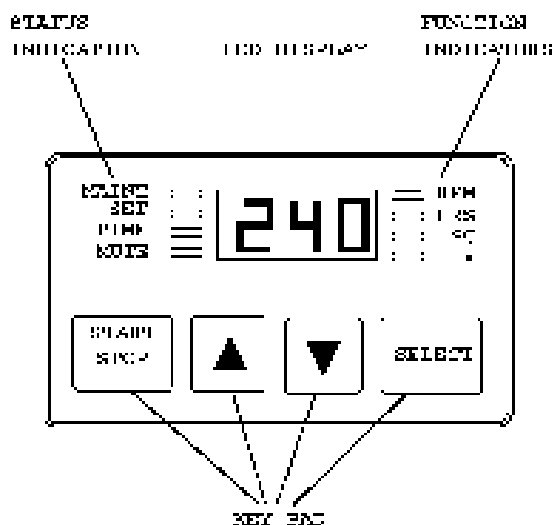

2.3.1 LED Display

The display on the Innova control panel is a three-digit LED display. During normal shaker operation, the display will indicate:

- Shaker status (on/off)
- Shaking speed
- Setpoints
- Hours remaining (timed run)
- Measured temperature (when temperature/monitor option is installed)

2.3.2 Keypad

There are four user interface keys on the keypad:

- | | |
|---------------------|---|
| START/STOP | This key is used to start or stop the shaking motion. It will also activate or stop the timer when a timed run is desired. |
| SELECT | This key is used to change the displayed parameter. Temperature (°C) cannot be selected unless the temperature/remote monitoring option is installed. |
| σ and τ | These keys are used to adjust the setpoint of a displayed parameter up or down. They also allow the user to enter the Set mode for setpoint changes. |

2.3.3 Status Indicator Lights

Four status indicator lights are located to the left of the LED display:

MAINT	Remains lit after 10,000 hours of use. Accumulated running time is internally monitored and may be displayed as a guideline.
SET	Indicates that the shaker is in the Set mode and setpoints are being displayed and can be altered.
TIME	Indicates that the timer is in operation. Innova shakers can be programmed to run for a preset time from 0.1 hour to 99.9 hours. The timer can be disengaged.
MUTE	Indicates the status of the audible alarm. When the Mute indicator is illuminated the audible alarm device is disabled.

2.3.4 Function Indicator Lights

Four function indicator lights are located to the right of the LED display. They indicate the current parameter being displayed:

RPM	Revolutions per minute
HRS	Time remaining in a timed run
°C	The temperature function will be activated only if the temperature/monitor option is installed.
*	Not applicable to the Innova 2180

2.4 Platform Assemblies

The Innova 2180 was designed for use with a custom-ordered or customer-provided 18" x 18" (46cm x 46cm) reaction-block platform.

This shaker can be also used with a wide variety of NBS 18" x 18" (46cm x 46cm) platforms which will accept a variety of clamps for flasks, test tubes, etc. (*see Section 7.2*).

2.5 Heavy Duty Construction

The Triple Eccentric Drive used in Innova shakers employs the same proven technology which has driven New Brunswick Scientific's shakers for over 30 years. This drive mechanism (see Figure 4 on the following page) utilizes a counterweight system to stabilize the rotary motion produced during operation. When the work load moves in one direction, opposing forces are generated to stabilize the shaker. This action will help eliminate the problem of "walking" which may occur with less precisely balanced instruments. Vibration is minimized and the life of the unit is extended.

Figure 4: Counterbalanced Drive Mechanism

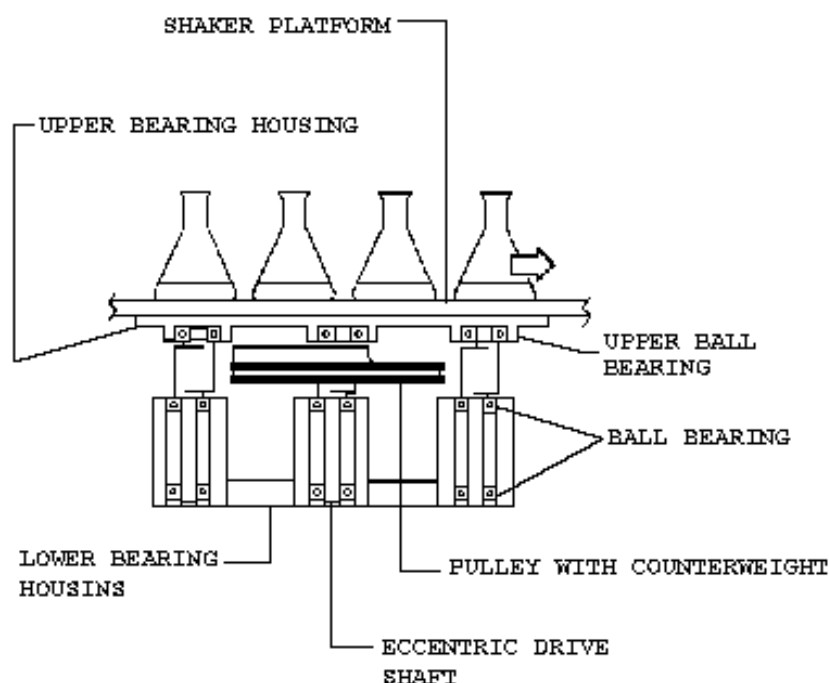

2.5.1 Bearings

Innova shakers employ sealed lubricated ball bearings of the highest quality. Sealed bearings minimize the generation of airborne particulates which may be disadvantageous in clean rooms or controlled environment areas. Such bearings require no maintenance and have run reliably in New Brunswick Scientific shakers for many years.

2.5.2 Motor

The Innova 2180 shakers use a three-phase brushless ball bearing DC motor. This low profile motor provides high torque along with quiet, efficient operation and low maintenance. The rugged motor has a rating of 1/15 horsepower.

2.6 Temperature/Monitor Option

A Temperature/Monitor Option is available (NBS part number M1194-9924) for installation on the Innova 2180. The temperature of liquid in any vessel or the ambient temperature can be measured using the RTD electronics-based measuring device supplied with this option. When the option is installed, the LED will display the measured temperatures in 0.1°C increments.

This option also allows the connection of a chart recorder so that temperature and shaking speed can be documented. The analog output for shaking speed is 0-5V, 1V per 100 RPM. For temperature, the output is 0-5V with .05V per °C. The output can also be connected to a data logging computer with an analog data acquisition card.

2.7 Electronic Boards

The main control board for the Innova shaker has the following functions:

- Storage of key parameters during power interruption in a non-volatile memory.
- Speed sensing, electronic commutation, and power control for the brushless DC drive motor.
- Maintenance of an elapsed running time clock.
- Shaker control and recognition of an expansion connector for option modules via integrated firmware.
- Provision of an operator interface via displays, audible alarm and connection to the keypad module (keypad buttons and display graphics).

The optional temperature module is designed to piggyback onto the main board via an expansion connector. It has the following functions:

- Control of analog power supplies.
- Signal conditioning of RTD sensor readings.
- Provision of remote monitoring capabilities by supplying analog outputs for speed and temperature which are compatible with chart recorders and analog data acquisition systems.

3 INSTALLATION

3.1 *Unpacking*

Upon unpacking the unit, inspect it carefully for any apparent damage that may have occurred during transit. Immediately report any damage to the carrier and to the New Brunswick Scientific Service Department.

Do not discard the crate or packing material.

VERY IMPORTANT: There are two small plastic straps that hold the bearing housing in place for shipping. Be sure to remove these two straps before operation.

3.2 *Checking Voltage Configuration*

Do not plug your shaker into the power source until you determine that voltage of your unit (by checking the voltage indicator and label on the rear of the unit) matches your electrical service.



NOTE:

Use of the Innova shakers requires a platform, which is a separate item. The Innova 2180 uses 18-inch by 18-inch (46cm x 46cm) platforms. A reaction-block platform can be custom-ordered. For other available platforms, see *Section 7, Parts & Accessories*).

3.3 *Space Requirements*

It is essential that the unit be situated in an area where there is sufficient space for the shaker and platform to clear walls and other potential obstructions during operation.

The dimensions, including a platform but excluding glassware, are:

<i>Width</i>	<i>Depth</i>	<i>Height</i>
19 inches	21 $\frac{7}{8}$ inches	6 $\frac{3}{8}$ inches
48 cm	55.5 cm	17 cm

The effective surface area required for operation is:

<i>Model</i>	<i>Width</i>	<i>Depth</i>
Innova 2180	22 inches	24 inches
	56 cm	61 cm

Figure 5: Space Requirements

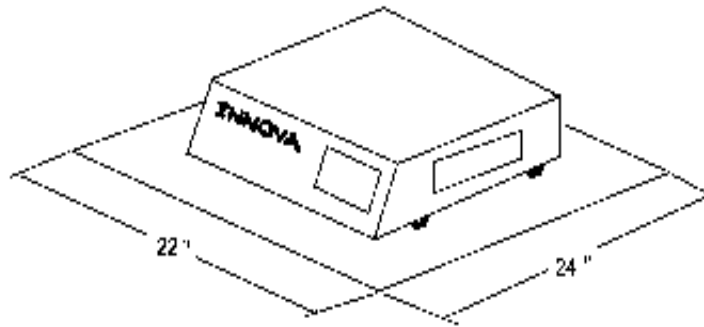

3.4 Electrical Connections



CAUTION!

Before making electrical connections, be sure to do the following:

1. Check that the power module at the rear of the unit is set to the correct voltage, corresponding to your power source. If it is not, refer to *Changing Voltage in Section 6.2*.
2. Remove the caution label from the universal power module.
3. Make sure the plastic straps have been removed from the upper bearing housing.
4. Make sure the power switch on the back of the unit is set in the OFF position.

ONLY THEN:

5. Connect the line cord to the power module and to a grounded electrical outlet.



CAUTION!

A grounded electrical outlet is necessary for the safe operation of this shaker.

3.5 ***Installing the Platform***

A platform must be installed on the unit prior to use.

1. Set the power switch in the Off position.
2. Using the 7/32-inch hex wrench provided, remove the four Allen head platform screws installed in the subplatform of the bearing housing (under the shaker). One of the four screws has a tag so you can identify it. Set them aside for reuse.
3. Place the platform on top of the shaker's subplatform. Be sure to use the proper size platform for your particular model shaker (*see Section 7.2 , Interchangeable Platforms*).
4. Reinstall and tighten the four platform screws (previously set aside) with the hex wrench to secure the platform.

3.6 ***Clamp Installation***

Flask clamps purchased for use with universal platforms require installation. Clamps are installed by securing the base of the clamp to the platform. Flat head screws of different lengths and thread pitch are used. Consult the Flask Clamp Hardware reference tables in *Section 7.4* to identify the proper screw for your shaker application by reference to the head style.

All clamps are shipped complete with hardware. Clamps for 2- to 6-liter flasks are shipped with an additional girdle to keep the flasks in place. To install 2- to 6-liter clamps:

1. Place each clamp on the platform, secure the clamp in place with the correct type and number of screws.
2. Place the loose girdle around the upper portion of clamp body (*see Figure 6 on the following page*) so that it is held in place by the legs of the clamp.
3. Insert the flask into the clamp.

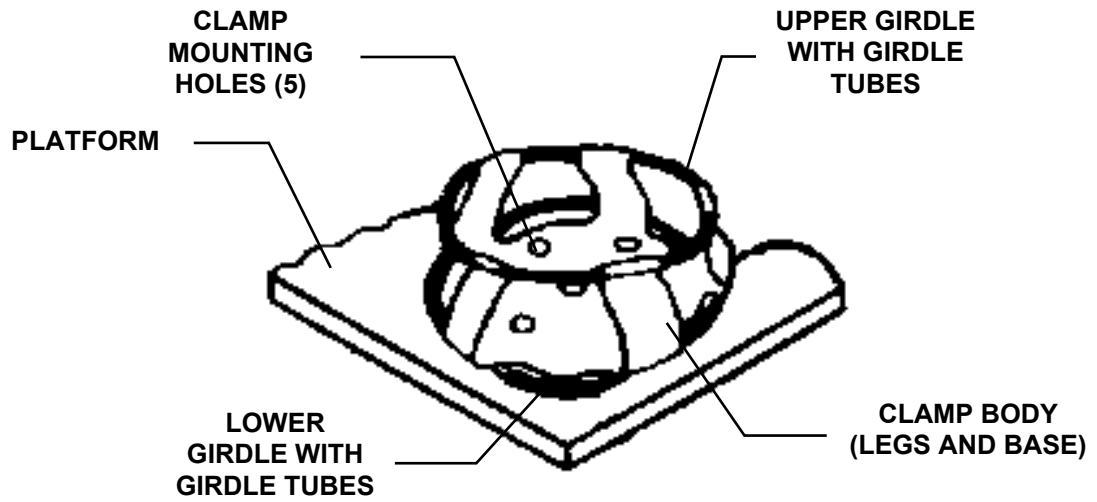
Figure 6: 2- to 6-Liter Clamp Installation

 **NOTE:**

Also applicable to 2800 ml Fernbach Flask Clamp.

4 OPERATION

4.1 Starting the Shaker

To start the unit, turn the power (On/Off) switch on the back of shaker to the ON position.

The shaking action may be stopped or started by pressing the Start/Stop key.

When the shaker is running, the LED display will track the speed as it accelerates to the last entered setpoint.



NOTE:

At higher speed ranges, we recommend that the platform have a 50% minimum load to maintain a good balance condition.

4.2 Continuous (Unlimited) Run

1. If the LED displays “OFF”, press the Start/Stop key.
2. Press Select until RPM is lit.
3. Press either σ or τ to enter Set mode (Set indicator will light).
4. Set the speed by using the σ or τ key until the desired setpoint is displayed. Holding the σ or τ key will cause the setting to change more rapidly.

The setpoint may be changed during a run without stopping the shaker by following steps 2-4. During speed changes, the alarm may sound until the speed returns to within 5 RPM of the setpoint.

4.3 Checking a Setpoint

1. Press Select until the desired indicator is lit.
2. Press either σ or τ to enter the Set mode and display the current setpoint.



CAUTION!

Holding the σ or τ key for more than 0.5 second causes the speed setpoint to change. Should this occur, resetting will be necessary.

4.4 *Timed Functions*

The shaker may be programmed to stop automatically after a preset time period of 0.1 hour - 99.9 hours. There must be power to the shaker in order to set the timer. However, a timed run can be initiated while the unit is either shaking or stopped.

4.4.1 **Setting the Timer**

1. Press the Select key to light HRS.
2. Press either σ or τ to enter the Set mode, then set between 0.1 hour - 99.9 hours.
3. While Set light is lit, press the Start/Stop key. This will program the time (and start the run). The Time indicator will light and remain on for the duration of the run. At the end of the timed run, the display will read "OFF", the Time indicator will flash, and the audible alarm will sound.
4. The setpoint may be changed during a run without stopping the shaker by following steps 1 and 2.

4.4.2 **Stopping the Alarm**

To stop the alarm, press the Select key and change to any other function.

4.4.3 **Cancelling the Timer**

To cancel the timer **without** stopping the shaker:

1. Press the Select key to light HRS.
2. Press either σ or τ to enter the Set mode, then immediately press the Start/Stop key. The Time indicator will go out and the display will read "OFF".

4.5 *Alarm Functions*

Innova shakers have an audible alarm which is activated at predetermined times. It may be deactivated in the following way:

1. Press Select to light HRS.
2. **Simultaneously** press the σ and τ keys. The Set and Maint indicators will flash.
3. While the Set and Maint indicators are flashing, press the Start/Stop key. The Mute indicator will light to advise that the audible alarm is deactivated.

The alarm may be reactivated by repeating steps 1-3. The Mute indicator will be extinguished when the alarm has been reactivated.

**NOTE:**

The shaker may be started or stopped by pressing the Start/Stop key. When starting, the unit will automatically return to the most recent function and speed setting. The audible alarm will be activated until the speed is within 5 rpm of the setpoint. The alarm will not sound, however, when the shaker is accelerating immediately after the power is turned on.

4.6 **Total Running Time**

The control modules of the Innova shakers keep track of the time the shaker has been on, tracking the hours of usage.

To display the accumulated running time:

1. Select HRS using the Select key.
2. **Simultaneously** press the σ and τ keys.

The Set and Maint indicators will flash and the accumulated running time will be displayed in hundreds of hours (i.e., “02” equals 200 hours; “102” equals 10,200 hours). This display will continue for 10 seconds and then default to the previous mode readout.

After 10,000 hours of operation, the Maint indicator will light. Preventive maintenance is recommended at this point. The NBS Service Technician will deactivate the light when the technician performs the required maintenance.

Alteration of the internal clock by unauthorized personnel will void the warranty.

4.7 **Temperature/Monitor Option**

This option consists of an internal electrical interface, an RTD temperature probe and an analog output for chart recorder or computer. When this option is installed, either the ambient temperature or the temperature of any vessel on the shaker platform can be measured with the probe:

1. Remove the probe from its holder and insert it into the vessel to be monitored.
2. Use the Select key to indicate °C.

The °C indicator will only function when the temperature/monitor option is installed.

Since the temperature/monitor option does not provide temperature control, any attempt to enter a temperature setpoint results in the display of “Err” (Error) on the control panel.

4.8 Recorder Adaptation

To record speed and temperature, a recorder (not supplied) can be used. The recorder will need to have two channels, for speed and temperature. Each channel should have signal conditioning that accepts 0-5 volt input.

A mating connector is required on the recorder cable (not supplied). This is a 9-pin male D subminiature connector, AMP Amplimate HDP-20 series or the equivalent. The pin-out diagram below identifies the application:

**Figure 7: Recorder Connector
(as seen from the rear of the unit)**

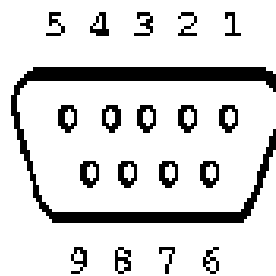

<i>Pin No.</i>	<i>Signal Name</i>	<i>Scale</i>
6	Speed	1V = 100 RPM
2	Ground	
7	Temperature	1V = 20°C
3	Ground	

5 MAINTENANCE

The Innova Shaker requires no routine maintenance on the part of the user, other than cleaning. At the end of 10,000 hours of use, the Maint indicator light illuminates. At that time, contact your local NBS Service Engineer or call the NBS Service Department for a maintenance visit. This periodic maintenance will keep your unit in premium condition.



WARNING!

Before performing any maintenance on the unit, *always* turn the power OFF using the power switch on the rear of the shaker, and disconnect the line cord.

5.1 Cleaning

The unit may be cleaned using a damp cloth or any standard, household or laboratory cleaner to wipe down its outer surfaces.

Do not use abrasive or corrosive compounds to clean this instrument, as they may damage the unit and void the warranty.

THIS PAGE INTENTIONALLY BLANK

6 SERVICE

The following section describes basic troubleshooting service procedures, and provides instructions to install optional features. These must be performed by a qualified service engineer.

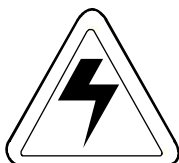

WARNING!

Before performing any service or maintenance on the unit, always turn the power OFF using the power switch on the rear of the shaker, and disconnect the line cord.

6.1 Replacing Fuses

To replace fuses (without changing the fusing arrangement), the service technician will follow these steps:

1. Always disconnect the unit from the power source first.
2. Using a small screwdriver, remove the cover/fuse block located on the rear of the unit. Remove the old fuse.
3. Insert a new one of the same type.
4. Replace the cover/fuse block into the power module (*see Figure 8*).

Figure 8: Power Entry Module

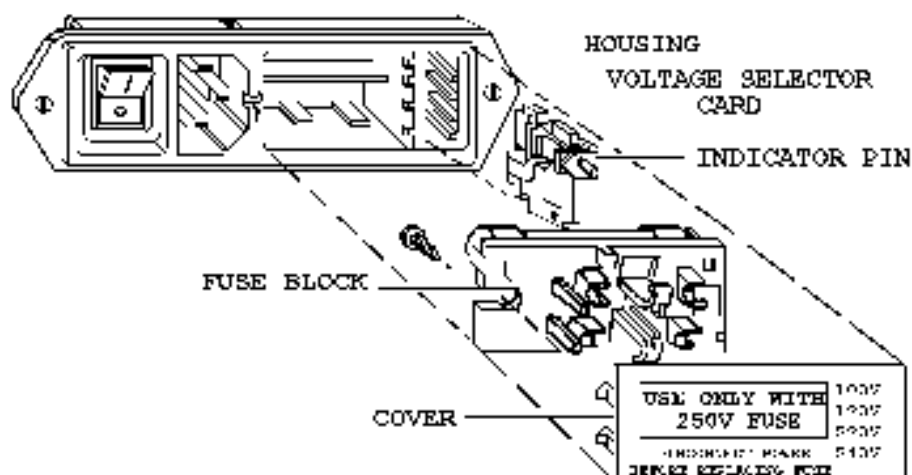

6.2 Changing Voltage

Innova shakers are set at the appropriate line voltage with the proper fuses prior to shipment. The power module, however, is a universal power-entry system that can be reset to adapt to worldwide power requirements. If it becomes necessary to reset the voltage on your shaker, the authorized technician will use the following procedure.

1. Disconnect the unit from the power source.
2. Open the cover of the power module, using a small blade screwdriver, and remove the cover/fuse block assembly (see Figure 8).
3. Remove the voltage selector card from the housing by pulling the indicator pin straight out (see Figure 8).
4. Along each edge of the voltage selector card, the voltage options are printed in large numbers - 100, 120, 220, 240 (see Figure 9). Place the card in front of you with the desired voltage printed at the bottom.
5. With the card in this position, orient the indicator pin to point up. The voltage has now been changed and the card can be reinserted.

Figure 9: Voltage Selection

VOLTAGE SELECTOR CARD ORIENTATION

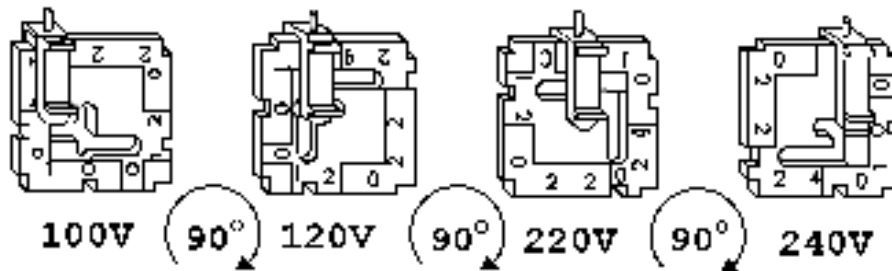

6. Hold the voltage selector card so that the indicator pin is facing you and the alignment arrow points left (see Figure 10, on the following page).
7. Replace the card in the voltage selector slot at the right hand end of the power module. Push it until it snaps into place.
8. Check for the correct fusing arrangement (see *Fusing*, in the following section).



NOTE:

Be sure the pin is facing out and the alignment arrow is pointing to the left.

9. Reinstall the cover/fuse block assembly.
10. Verify that the indicator pin shows the desired voltage.

**Figure 10: Indicator Pin & Alignment Arrow
(Voltage Selection)**

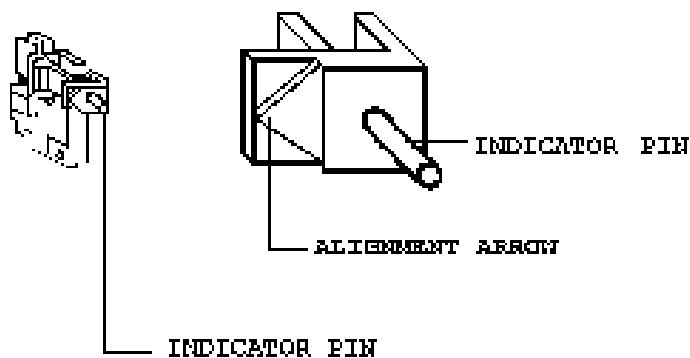

6.3 *Fusing*

If you change the voltage on the shaker, it may also be necessary to modify the fusing arrangement, from a single fuse to double fuses.

6.3.1 **From Single to Double Fusing**

To convert from a single fuse to double fusing, the authorized service technician will:

1. Open the cover of the power module, using a small blade screwdriver, and remove the cover/fuse block assembly (*see Figure 11 on the following page*).

Figure 11: Power Module & Fuse Block

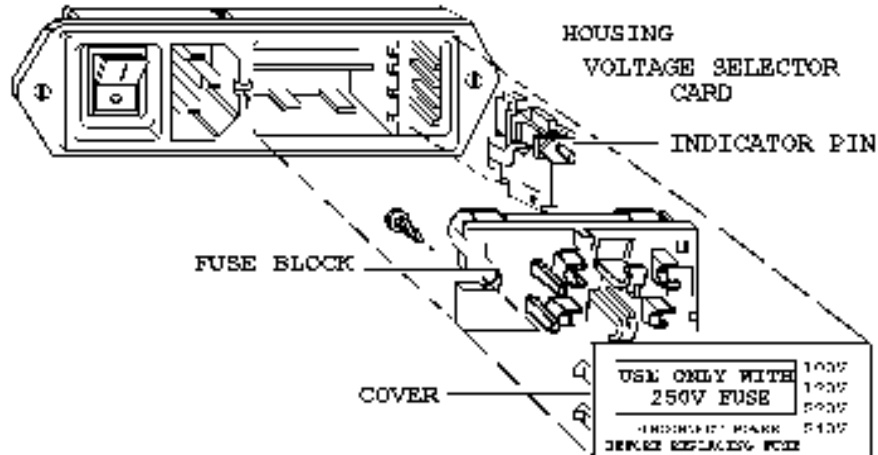

2. Loosen the Phillips head (+) screw two full turns (*see Figure 12 below*).

Figure 12: Fuse Block/Cover Assembly

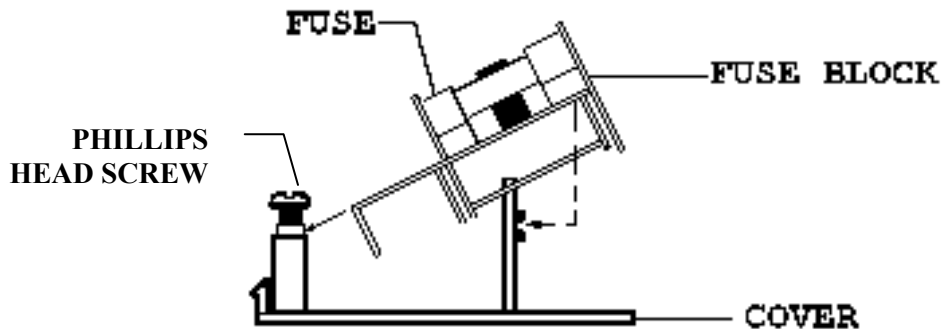

3. Remove the fuse block by sliding it up and away from the screw shaft and lifting it off the pedestal (*see Figure 12 above*).
4. Invert the fuse block, then slide it back onto the Phillips head (+) screw and pedestal. Tighten the Phillips head screw.
5. Verify the correct fusing arrangement (*see Figures 13a & 13b on the following page*).
6. Replace the cover onto the power module.

Figure 13a: Double Fuse Arrangement

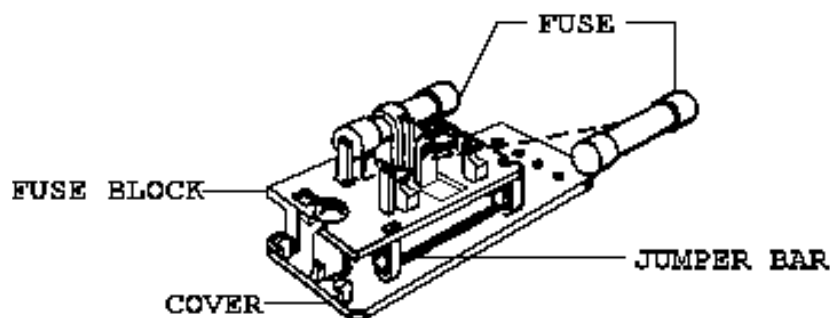
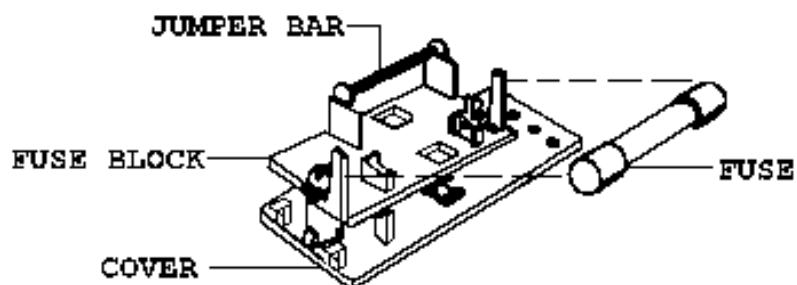

Figure 13b: Single Fuse Arrangement



6.4 Belt Replacement

A service kit (NBS Part Number P0700-5302) is provided to aid the authorized service technician in replacing the drive belt. The kit consists of a 7½-inch x 8-inch (19cm x 20cm) Housing Extractor Plate (*Item* ← in Figure 14, on the following page) and three 3/8-16 NC x 1¼-inch long flat head Allen screws (*Item* ↑). These are attached to the bottom of the shaker. To remove the kit, unscrew the three fasteners with the large Allen key provided.

All *Item* numbers in the following instructions refer to Figure 14.

1. Thread the three 1¼-inch long screws (*Item* ↑) into the three threaded holes in the extractor plate until they are flush to the back of the plate.

2. Remove the platform from the Innova shaker by unscrewing the four ¼-inch flat head screws (*Item* °).
3. Using the small Allen key, remove the three ¼-20 x ½-inch long flat head Allen screws (*Item* →) that hold the bearings in place on the upper housing. Also remove the three countersunk washers (*Item* ↓).
4. Orient the plate on the upper bearing housing so that the three 3/8-inch screws (*Item* ↑) sit in the center of the three bearings.

Figure 14: Upper Bearing Housing & Extractor Plate Detail

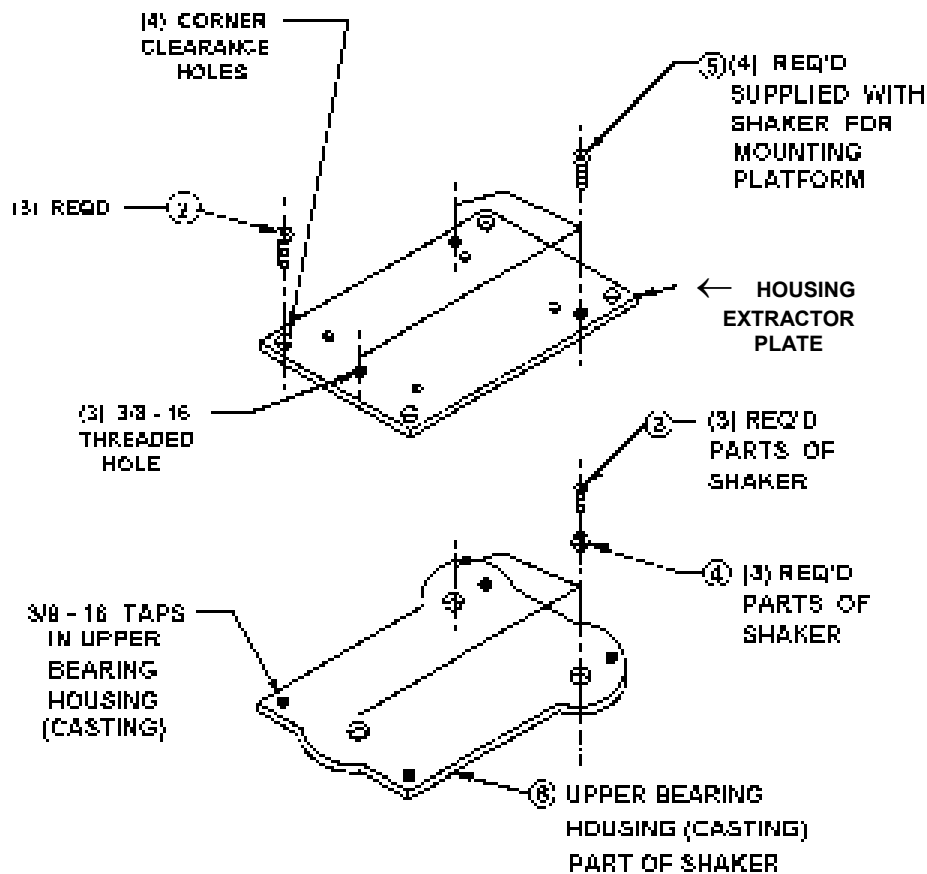

5. Use the large Allen key provided to mount the plate to the upper housing, utilizing the four platform screws (*Item* °) set aside in Step 2. Tighten the four screws securely (*see Figure 15 on the following page*).
6. Using the larger Allen key on the three 3/8-inch screws (*Item* ↑), turn each screw one half turn in sequence until the upper bearing housing is lifted free of the eccentric shafts. Remove the four platform screws (*Item* °), thus disconnecting the plate from the upper bearing housing (*see Figure 15*).

**Figure 15: Bearing Housing Assemblies
(with extractor plate in place)**

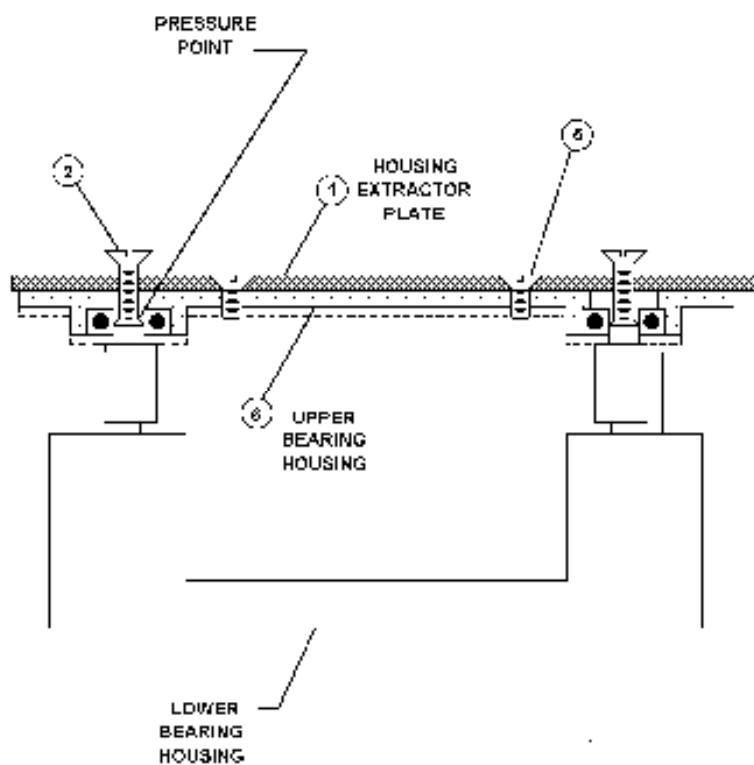

7. Remove the old belt by rotating the pulley slowly and feeding the belt out with a slight upward pressure on the belt.
8. Install a new belt: slip the new belt over the main eccentric shaft, which is the shaft with the counterweight.
9. Position the three eccentric shafts so that they all face the same direction (*see Figure 16 on the following page*).
10. Using a soft mallet or the back end of a wooden hammer handle, lightly tap the upper housing near the three bearings until there is even engagement of the bearings onto the shafts. **NEVER TAP THE CASTING WITH METAL.**

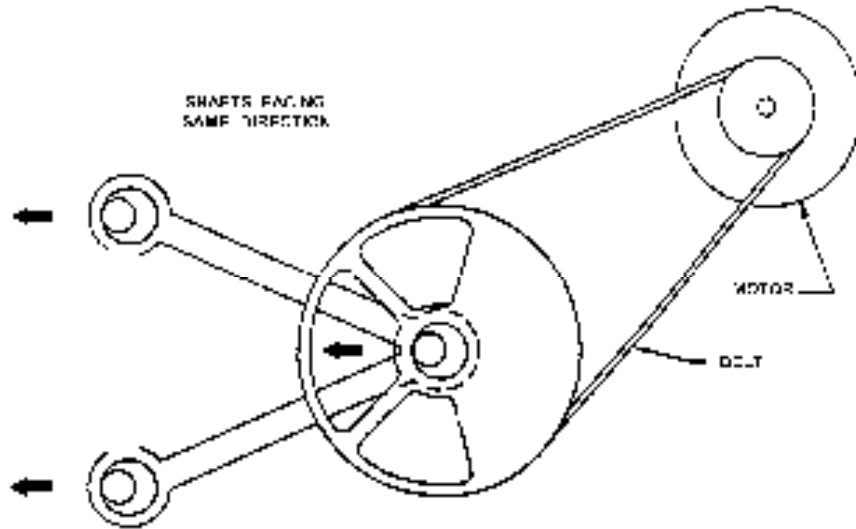
Figure 16: Eccentric Shafts & Pulley

11. Place the three washers (*Item ↓ in Figure 14*) set aside in Step 3, with countersink face up, onto each of the bearings.
12. Reinstall the three $\frac{1}{4}$ -20 x $\frac{1}{2}$ -inch long flat head screws (*Item → in Figure 14*) through the washers and engage the eccentric shaft threads. Tighten evenly in sequence and be sure each bearing is fully seated on the shaft.
13. Guide the belt onto the two pulley grooves. Check the belt adjustment by applying finger pressure to the belt midway between the two pulleys. The belt should deflect approximately $\frac{3}{8}$ inch (9.5 mm). *If the belt requires further adjustment, see Belt Adjustment, the following section.*
14. Replace the platform. The machine is ready for operation

6.4.1 Belt Adjustment

If the belt does not deflect approximately $\frac{3}{8}$ inch (9.5 mm), an adjustment is required:

1. Loosen the two hex nuts on the motor assembly (*see Figure 17 on the following page*).

Figure 17: Motor/Mounting Plate Assembly

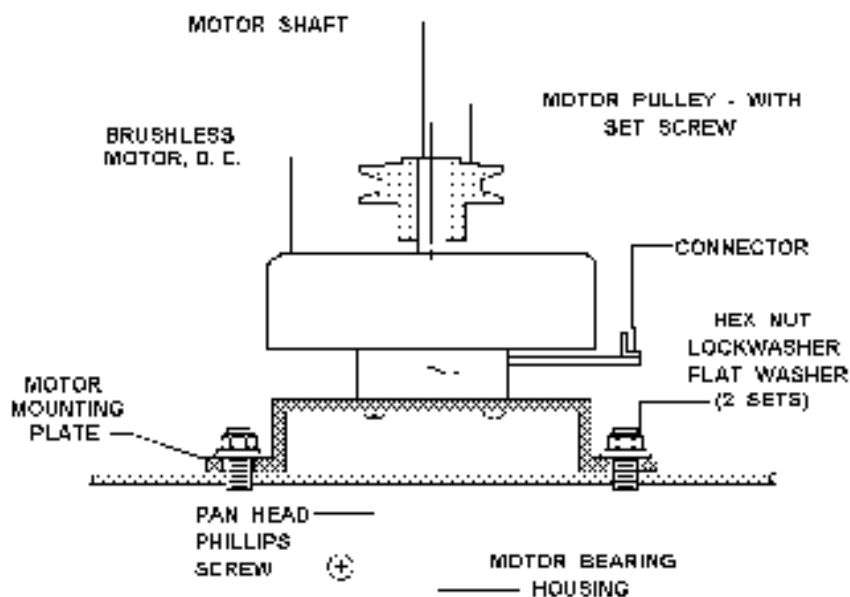

2. Move the motor assembly until the belt is tight.
3. Tighten the hex nuts and recheck the belt tension by exerting pressure on the belt. The belt should deflect approximately $\frac{3}{8}$ inch (9.5 mm).
4. Replace the platform. The machine is ready for operation.

6.5 Motor Assembly Replacement

If the motor assembly needs to be replaced, the authorized service technician will:

1. Remove the platform.
2. From the deck, remove the two hex nuts and washers that retain the motor mounting plate (*see Figure 17, repeated on the following page*).
3. Remove the belt and carefully disconnect the harness connector from the motor assembly.
4. Loosen the set screw that holds the motor pulley in place and remove the pulley (*see Figure 17*).

Figure 17: Motor/Mounting Plate Assembly

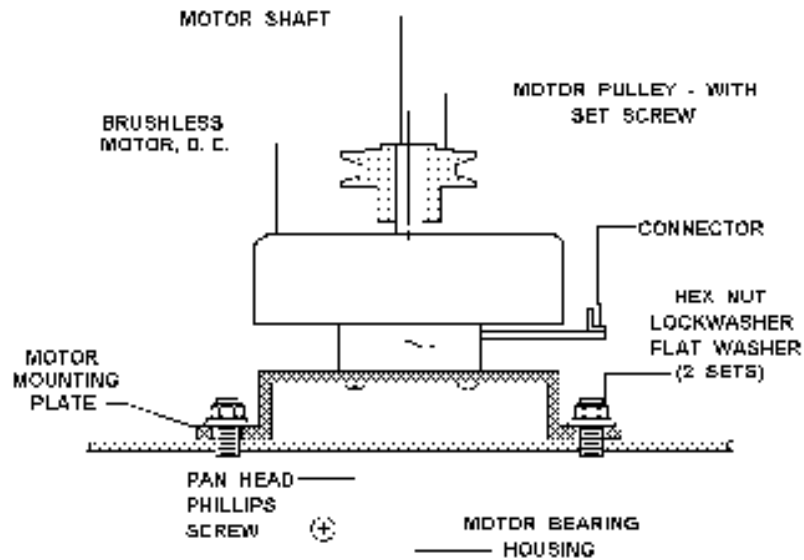

5. Remove the three 10-32 screws and lock washers that retain the motor bearing housing to the motor mounting plate. *Note the orientation of the electrical connector.*
6. Remove the motor assembly.
7. Mount the new motor assembly onto the motor mounting plate with the connector oriented as noted in Step 5 above. Tighten the three 10-32 screws with the lock washers in place.
8. Replace the motor pulley. Finger tighten the set screw, making sure the set screw is on the flat of the shaft.
9. Mount the assembly on the deck using the hex nuts and washers removed in Step 2 (*see Figure 17*). Tighten the hex nuts just until they come into contact with the deck.
10. Connect the harness connector to the motor assembly with the orientation noted in Step 5. The left side of the connector (as you face the motor) **must** be flush with the motor connector, and the blank pin **must** be visible on the right side (*see Figure 18 on the following page*). Also, ensure the cable is routed so it clears all moving parts.
11. Guide the belt into the pulley grooves. Adjust the height of the motor pulley so that the belt is parallel to the base (use a straight edge across the pulleys). Tighten the set screw in the motor pulley.
12. Adjust the belt tension so that there is approximately a $\frac{3}{8}$ inch (9.5 mm) deflection in the belt. (*See Belt Replacement procedure for adjustments.*)

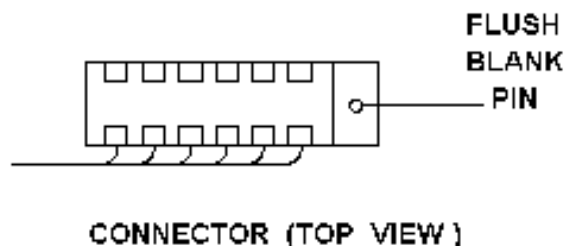
Figure 18: Proper Harness Connection

6.6 Temperature/Monitor Option

The temperature/monitor option package (NBS part number M1194-9924) is available for the Innova 2180, to provide the following features:

- Digital Temperature Readout: to monitor the ambient temperature or the temperature of the liquid in any vessel with an RTD-based electronic device. The value is displayed on the LED readout on the control panel when the option is installed.
- Remote Monitoring: 0-5V analog recorder output for both temperature and speed. Can be used with an external chart recorder or a computer that has a data acquisition card.

When the authorized service technician performs the retrofit installation of this option, he will first determine that the following parts are included in the kit:

Quantity	Description	NBS Part No.
1	Installation instructions	TM1194-9924
1	Temperature Monitor PC Board	M1192-7000
1	RTD Temperature Sensor Assembly	M1194-8000
1	RTD & Recorder Cable Assembly.	M1191-8020
1	Bracket Assembly	M1194-5000
1 Mounting Hardware Kit, consisting of the following:		
3	Hex spacers 6/32 inch x ½ inch	P0160-2273
3	6-32 x ¼ inch Pan head Phillips screws	
2	6-32 x 5/16 inch Pan head screws	
2	6-32 x ½ inch Pan head screws	
1	Jack screw kit	P0100-7641
3	Nylon washers	P0100-9090
2	#6 flat washers	
4	#6 lock washers	
2	6/32 hex nuts	
2	Cable clamps	EC-157

The authorized technician will follow these steps to install the kit :

1. Stop the shaker with the Start/Stop key (if necessary).
2. Turn the unit Off using the power switch on the shaker's rear panel, and remove the line cord.
3. Remove the shaker platform.
4. Remove the five screws that hold the front panel, allowing the front panel to lay on its face (*see Figure 19*).
5. Remove the three nuts and three washers from positions A, B and C on the main control board (*see Figure 19*).

Figure 19: Front Panel Assembly

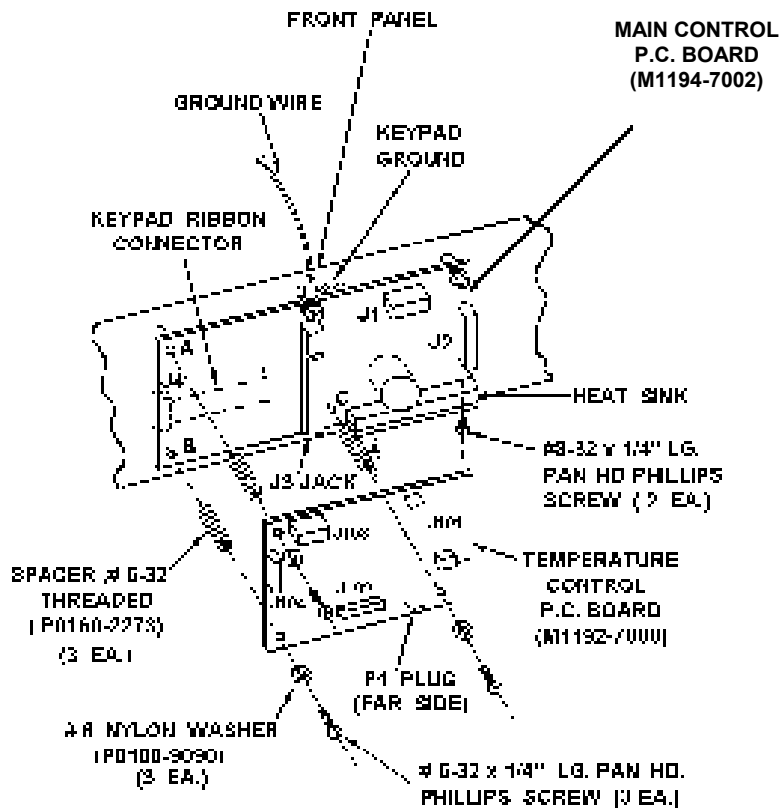

6. Screw on the three hex spacers (P0160-2273) in positions A, B and C (*see Figure 19 above*).
7. Align the mating connector on the temperature module PC board with the option connector on the main control board and press down until the connector is seated (*see Figure 19*).
8. Secure the temperature module to the main control board with the three 1/4-inch screws and nylon washers provided.
9. Remove the cover plate at the rear of the shaker (*see Figure 2*). Retain the mounting hardware.

10. Mount the RTD (round connector) with the hardware used to hold the cover plate.
11. Mount the chart recorder connectors with the hardware provided in the jack screw kit (P0100-7641).
12. Carefully route both cables along the lower right side of the shaker and secure with the cable clamps and ½-inch long screws provided.
13. Connect the 4-pin connector coming from the chassis harness assembly to J101, cutting the plastic strap (see Figure 19).
14. Connect the RTD cable's 6-pin connector to J103 on the temperature control module (see Figure 19).
15. Connect the chart recorder cable's 10-pin connector to J104 on the temperature control module (see Figure 19).
16. Carefully put the front panel back in place and secure with screws.



CAUTION!

Before tightening the screws, make sure that no wires are pinched between the front panel and the shaker chassis.

17. Place the unit on its side. Mount the RTD bracket assembly (M1194-5000) and the ½-inch pan head screws provided.
18. Place unit in its normal operating position, and reinstall the platform.
19. Connect line cord to the back of unit.

See Features Section 2.6 and Operation Sections 4.7 and 4.8 for details on the temperature monitor and chart recorder functions.

6.7 Replacing Electronic Boards



WARNING!

The following procedure is to be performed ONLY by an authorized Service Technician.



WARNING!

Integrated circuits are extremely susceptible to damage from electrostatic discharge (ESD). Read and follow the precautions in the following section before proceeding.

6.7.1 ESD Precautions

1. Do not remove components from their antistatic packaging until you are ready to insert them into their sockets or install the board.

2. Wear a wrist grounding strap, available from most electronic component stores.
3. Before handling components or boards, touch an unpainted portion of the system unit chassis for a few seconds.

6.8 *MAINT Indicator*

After 10,000 hours accumulated shaker running time, the Maint indicator light on the control panel will light. Only an NBS Service Engineer can turn it off.

The Maint light indicates that a routine maintenance check is recommended. Call NBS Service to schedule an appointment.

A regular schedule of routine maintenance is an excellent way to keep your valuable equipment performing optimally for years of reliable service.

7 PARTS & ACCESSORIES

7.1 Service Parts

NBS Part No.	Description	Quantity
P0380-3710	0.16A 5x20 mm Fuse	1
P0380-3530	1.6A 3AG Fuse	1
P0420-1610	10VA Transformer	1
M1191-5300	130VA Transformer Assembly	1
P0320-0350	2100 μ F Capacitor	1
P0460-4091	Diode Bridge	1
P0360-4040	130V Varistor	2
M1191-4001	Medium Motor Assembly	1
M1194-7002	Main Control P.C.B.	1
M1190-5000	Membrane Switch Panel	1
P0460-2200	Power Entry Module	1
P0720-2053	Power Cord 120V 10A	1
P0720-2021	Power Cord 220V	1
P0180-0102	Bearing, Sealed, Upper	3
P0180-0101	Bearing Shield, Lower	6
P0700-5302	Belt	1
M1194-6331	Bearing Housing Assembly	1
M1194-8000	Stainless Steel RTD Assembly (Optional)	1
M1194-0051	Innova 2180 Operations Manual	1

7.2 Innova 2180 Interchangeable Platforms

The following NBS platforms can be mounted on the Innova 2180, in the place of a custom-ordered or customer-provided reaction-block platform.

Catalog Number	18 x 18-inch (46 x 46cm) Platform Size*	
	Clamp Quantity	Size of Glassware
M1194-9909	Utility Carrier	
M1194-9910	Utility Tray	
M1194-9902	Universal Platform	
M1194-9903	64	50mL Erlenmeyer Flask
M1194-9904	34	125mL Erlenmeyer Flask
M1194-9905	25	250/300mL Erlenmeyer Flask
M1194-9906	16	500mL Erlenmeyer Flask
M1194-9907	9	1L Erlenmeyer Flask
M1194-9908	5	2L Erlenmeyer Flask

*All above platforms constructed of phenolic composite

7.3 Accessory Flask Clamps





NBS Catalog No.	Clamp Type
ACE-105	10mL Erlenmeyer Clamp
ACE-255	25mL Erlenmeyer Clamp
ACE-505	50mL Erlenmeyer Clamp
ACE-125S	125mL Erlenmeyer Clamp
ACE-250S	250mL Erlenmeyer Clamp
ACE-500S	500mL Erlenmeyer Clamp
ACE-1000S	1.0L Erlenmeyer Clamp
ACE-2000S	2.0L Erlenmeyer Clamp
ACE-4000S	4.0L Erlenmeyer Clamp
ACE-6000S	6.0L Erlenmeyer Clamp
ACFE-2800S	2800mL Fernbach Flask Clamp
ACSB-500S	500mL Media Bottle Clamp
ACSB-1000S	1.0L Media Bottle Clamp

All of the above clamps are stainless steel.





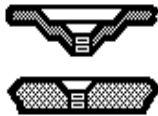

7.4 Clamp Mounting Hardware Kit

NBS Flask Clamps are used on a variety of shaker platforms. Flat head screws of different lengths and thread pitch are used to secure the clamp. The following tables identify the proper screw for your shaker application by reference to the head style.

7.4.1 Hardware for 10 mL to 500 mL Clamps

Description	Part Number	Qty.	Application
 10-24 x 5/8 (15.87 mm) flat Phillips (+) head screw	S2116-3101	1	$\frac{3}{4}$ " (19.05 mm) thick wood platform 
 10-24 x 5/16 (7.9 mm) flat Phillips (+) head screw	S2116-3051	1	5/16" (7.9 mm) thick aluminum, phenolic and stainless steel platforms. 
 10-32 x 5/16 (7.9 mm) flat slotted (-) head screw	S2117-3050	1	all stainless steel platforms 

7.4.2 Hardware for 1-Liter to 6-Liter Clamps

	<i>Description</i>	<i>Part Number</i>	<i>Qty.</i>	<i>Application</i>
	10-24 x 5/8 (15.87 mm) flat Phillips (+) head screw	S2116-3101	5	3/4" (19.05 mm) thick wood platform 
	10-24 x 5/16 (7.9 mm) flat Phillips (+) head screw	S2116-3051	5	5/16" (7.9 mm) thick aluminum, phenolic and stainless steel platforms.  
	10-32 x 5/16 (7.9 mm) flat slotted (-) head screw	S2117-3050	5	all stainless steel platforms 

**NOTE:**

The above chart also applies to 2800 mL Fernbach Flask Clamps.

7.5 Temperature/Monitor Option

The temperature and speed monitoring kit (NBS part number M1194-9924) allows an Innova 2180 to measure and display sample or ambient temperature and to record it on a remote chart recorder or computer. This kit consists of an internal electrical interface, an RTD temperature probe and an analog output for chart recorder or computer. **The package does not include a chart recorder.**

This kit must be installed by an authorized service technician.

THIS PAGE INTENTIONALLY BLANK

8 SPECIFICATIONS

This chapter provides technical details of interest, but not necessarily essential for operation of the instrument.

INNOVA 2180	
SHAKING	
Speed	25-800 RPM
Motion	0.180 inch (4.6 mm) diameter circular orbit
Indication	LED digital electric display, 1 RPM increments
Setpoint & Control	Digital adjustment with PI microprocessor control and instantaneous visual feedback
Accuracy	± 1 RPM (see NOTE at bottom of page)
DRIVE	
Triple eccentric counterbalanced ball bearing drive.	
TIMER	
<ul style="list-style-type: none"> • Programmable shaking periods from 0.1 hour to 99.9 hours by a digital timer that shuts off at the end of period and energizes status light. • Timer counts down and digital display indicates remaining time. Can be deactivated for continuous operation. • Additionally, unit will display total accumulated running time for service information. 	
AMBIENT OPERATING ENVIRONMENT	
0° - 60°C, 90% humidity, non-condensing	
SELF-DIAGNOSTIC STATUS	
Warning signal (audible and visible) indicates when shaking speed deviates more than 5 RPM and when timer operation has expired. The audible alarm can be deactivated/activated by the operator.	
REMOTE SPEED MONITORING (optional)	
<ul style="list-style-type: none"> • Chart recorder output for speed 0.5V, 1V per 100 RPM. • Accuracy ± 25mV. 	
TEMPERATURE MONITORING (optional)	
<ul style="list-style-type: none"> • RTD digital temperature monitor displays individual flask or ambient temperature in 0.1°C increments. • Chart recorder output provided. 	
AUTOMATIC RESTART	
<ul style="list-style-type: none"> • Unit will automatically restart after undesired power interruption. • Setpoints are maintained by non-volatile memory. • Interruption is indicated by a flashing LED display. 	



NOTE:

At 25-400 RPM, the unit will perform to specifications with up to $\pm 10\%$ line voltage fluctuation. To attain speed accuracy at 401-800, the line voltage cannot be lower than 5% of the rated voltage.

MOTOR		
1/15 HP, 3-phase brushless ball bearing DC motor.		
ELECTRICAL SERVICE		
<ul style="list-style-type: none"> • 100V, 120V, 220V, 240V • All voltages 50/60 Hz, 80VA. • Universal power entry system adapts to U.S. or international requirements. 		
ELECTRICAL PROTECTION		
<ul style="list-style-type: none"> • Main fuse(s) in power entry module. • Control circuits provided with separate fuse. 		
DIMENSIONS		
Width	19 inches	48 cm
Depth	21 $\frac{7}{8}$ inches	55.5 cm
Height (to platform surface)	6 $\frac{3}{8}$ inches	17 cm
PLATFORM DIMENSIONS		
	18 inches x 18 inches	46 cm x 46 cm
CONSTRUCTION		
<ul style="list-style-type: none"> • Heavy gauge steel, phosphate-coated and texture-painted cabinet. 		
WEIGHT		
Net	76 lbs	34.5 kg
Gross	120 lbs	54.5 kg

Figure 22: Control Schematic, Quadrant B

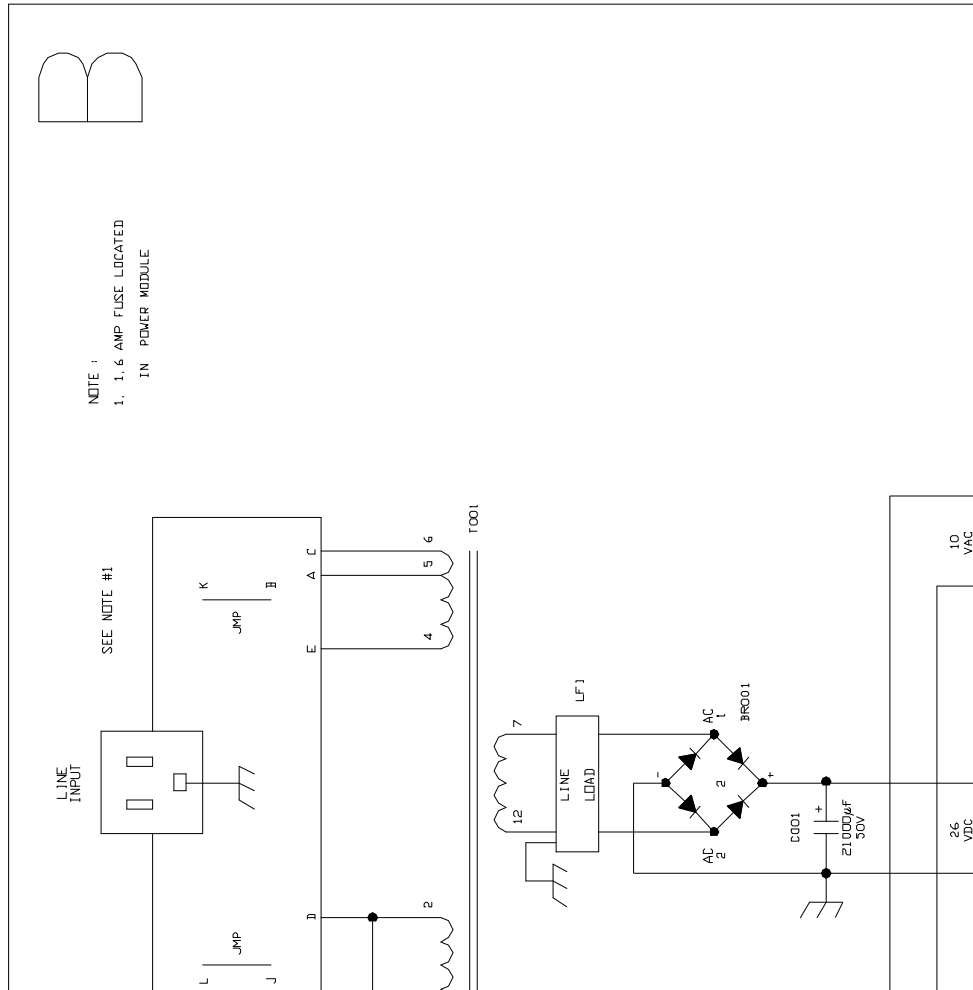

Figure 23: Control Schematic, Quadrant C

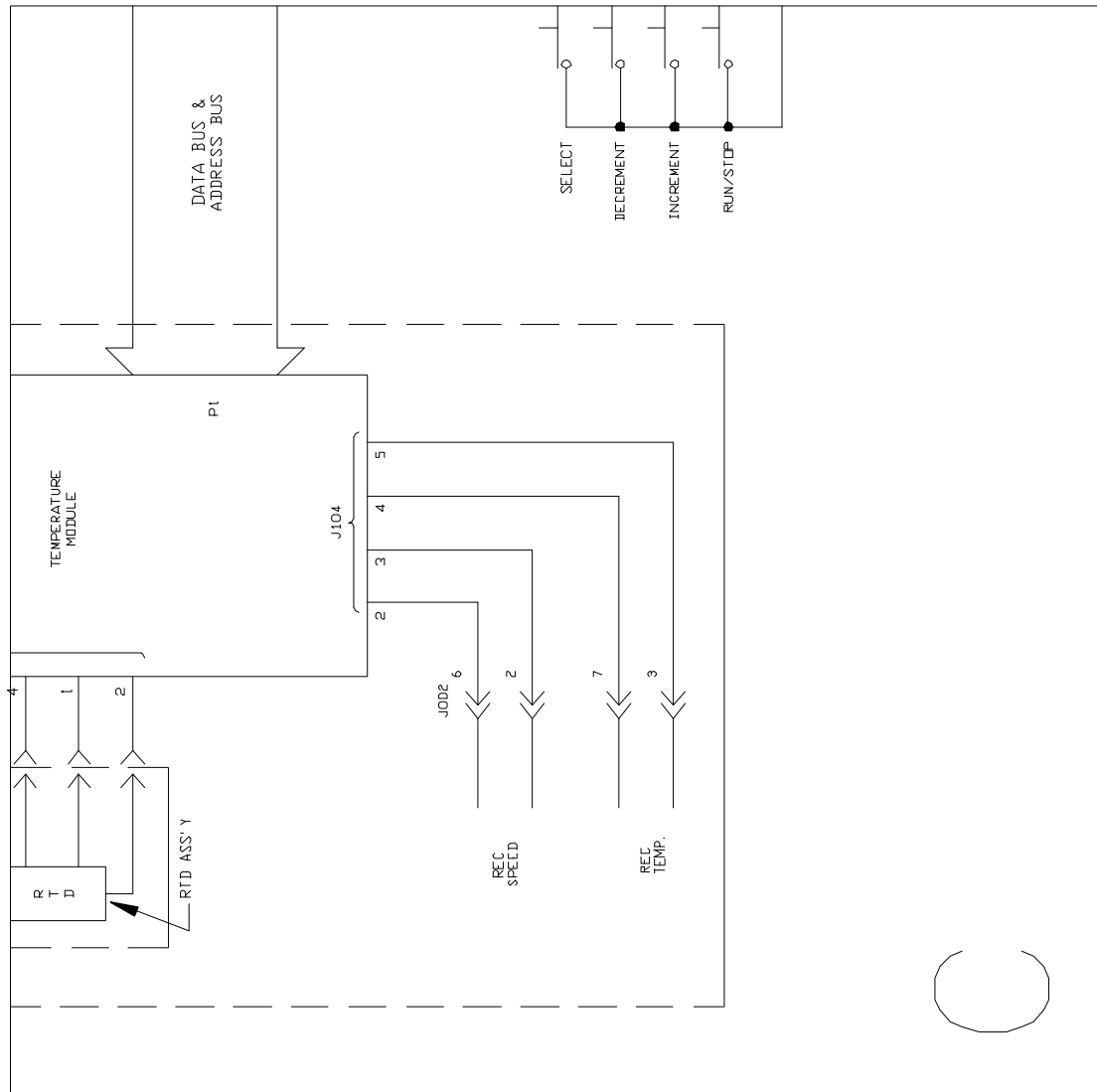
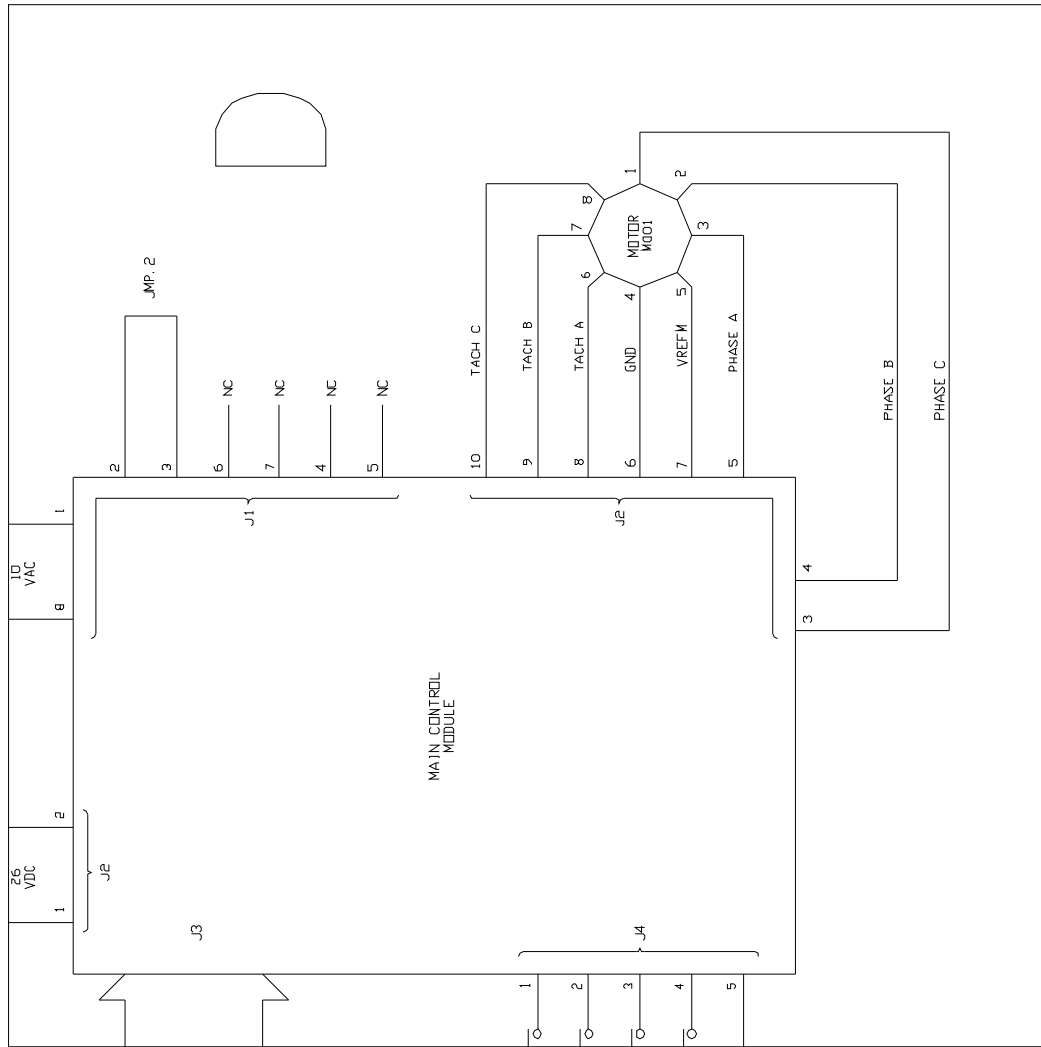

Figure 24: Control Schematic, Quadrant D



9.2 Drawing List

Figure	Description	Page
1	Front View	15
2	Rear View	16
3	Control Panel	17
4	Counterbalanced Drive Mechanism	19
5	Space Requirements	22
6	2- to 6-Liter Clamp Installation	24
7	Recorder Connector	28
8	Power Entry Module	31
9	Voltage Selection	32
10	Indicator Pin & Alignment Arrow (Voltage Selection)	33
11	Power Module & Fuse Block	34
12	Fuse Block/Cover Assembly	34
13a	Double Fuse Arrangement	35
13b	Single Fuse Arrangement	35
14	Upper Bearing Housing & Extractor Plate Detail	36
15	Bearing Housing Assemblies (with extractor plate in place)	37
16	Eccentric Shafts & Pulley	38
17	Motor/Mounting Plate Assembly	39, 40
18	Proper Harness Connection	41
19	Front Panel Assembly	42
20-24	Control Schematics	51-55

10 INDEX

- 2
- 2180 Specifications, 49
- A**
- Accessory Flask Clamps
List of, 46
- Alarms, 49
Deactivating the, 26
Reactivating the, 27
Stopping the, 26
- Ambient Operating Environment, 49
- Arrow Keys, 17
- Automatic Restart Features, 49
- B**
- Bearing Housing Retaining Straps, 21
- Bearings, 19
- Belt Adjustment, 38
- Belt Replacement, 35
- C**
- CAUTION
Symbol for, 7
- Clamp Mounting Hardware, 46, 47
- Clamps
Installation of, 23
- Cleaning, 29
- Continuous Run, 25
- Control Panel, 16
- Copyright Notice, 7
- Counterbalanced Drive Mechanism, 19
- D**
- Dimensions, 21
- Disclaimer Notice, 7
- Down Arrow Key, 17
- Drawing List, 56
- Drawings
2- to 6-Liter Clamp Installation, 24
Bearing Housing Assemblies, 37
- Control Panel, 17
- Control Schematic, 51, 52, 53, 54, 55
- Counterbalanced Drive Mechanism, 19
- Double Fuse Arrangement, 35
- Eccentric Shafts & Pulley, 38
- Front Panel Assembly, 42, 44
- Front View, 15
- Fuse Block/Cover Assembly, 34
- Index of, 56
- Motor/Mounting Plate Assembly, 39, 40
- Power Entry Module, 31
- Power Module & Fuse Block, 34
- Rear View, 16
- Recorder Connector, 28
- Single Fuse Arrangement, 35
- Upper Bearing Housing & Extractor
Plate Detail, 36
- Voltage Selection, 32
- Voltage Selection Indicator Pin &
Alignment Arrow, 33
- Drive Mechanism, 49
- E**
- Electronic Boards, 20
- Err* in Display, 28
- ESD Precautions, 43
- F**
- Features, 15
- Flask Clamps
List of, 46
- Function Indicator Lights, 18
- Fuse Replacement, 31
- Fuses, 33
Changing from Single to Double, 33
- H**
- Heavy Duty Construction, 19
- I**
- International Offices

-
- List of, 3
 - Introduction, 13
 - K**
 - Keypad, 17
 - L**
 - LED Display, 17
 - M**
 - MAINT Indicator, 27, 44
 - Maintenance, 29
 - Call for, 44
 - Manual Conventions, 7
 - Motor, 20
 - Motor Assembly Replacement, 39
 - N**
 - NOTE
 - Symbol for, 7
 - O**
 - On/Off Switch, 25
 - Overview, 13
 - P**
 - Platform
 - Installation of, 23
 - Platform Assemblies, 18
 - Platforms
 - List of, 45
 - Power Cord Connection, 29
 - Power On, 25
 - R**
 - Recorder, 27, 28, 41, 47
 - Connector Pin-out Diagram, 28
 - Remote Monitoring, 41
 - Remote Speed Monitoring, 49
 - Replacing Electronic Boards, 43
 - S**
 - Select Key, 17
 - Self-Diagnostic Status, 49
 - Service
 - Important Warnings about, 31
 - Service Parts List, 45
 - Setpoint
 - Changing a, 26
 - Checking a, 25
 - Setting a, 25
 - Shaking Accuracy, 49
 - Shaking Indication, 49
 - Shaking Motion, 49
 - Shaking Off, 25
 - Shaking On, 25
 - Shaking Setpoint & Control, 49
 - Shaking Speed, 49
 - Space Requirements, 21
 - Specifications
 - 2180, 49
 - Start/Stop Key, 17
 - Status Indicator Lights, 18
 - T**
 - Temperature Monitoring, 49
 - Temperature/Monitor Option, 20, 27, 41, 47
 - Installation of, 42
 - Timed Functions, 26
 - Timer
 - Cancelling the, 26
 - Features of, 49
 - Setting the, 26
 - Total Running Time, 27
 - Triple Eccentric Drive, 19
 - U**
 - Universal Power Module, 16
 - Unlimited Run, 25
 - Unpacking, 21
 - Up Arrow Key, 17
 - User Interface Keys, 17
 - V**
 - Voltage Selection, 21
 - Changing the, 32

